

SDL1 Liquid Leakage Sensor



Introduction

The leakage sensor uses the principle of light reflection to detect leakages, and comprises of infrared luminous parts, infrared light receiving parts, and prisms. It can detect leakages on stainless steel plates, plastic plates, and wooden boards. It is small, reacts fast, highly sensitive, and retracts immediately after contacting the liquid.

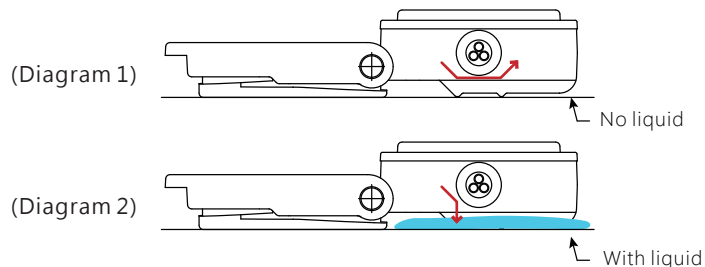

Diagram 1, the medium is air (no liquid).

The light is completely reflected to the sensor.

Diagram 2, the medium is liquid.

The light penetrates the plastic.

Application

Semiconductor process equipment, exposure devices, lithography machines, cleaning equipment, medical equipment, printing machines, etc.

Specifications

Detection method	Infrared optical
Standard detection object	water
Power supply	12 ~ 24 VDC
Current consumption	Max. 30 mA
Output type	3-wire NPN
	3-wire PNP
Action type	NO when normal, NC when leakage is detected.
	NC when normal, NO when leakage is detected.
Max. current output	50 mA
Max. voltage output	30 VDC
Residual voltage output	Max. 1V @ 50 mA
Circuit protection	Power supply reverse connection protection, short circuit protection
Indicator light	The green light is on when normal. The red light is on when leakage is detected.

Product Features

- The optical type can measure a variety of liquids and is unaffected by external ambient light.
- Easy installation with a base and lock mechanism.
- Easier to maintain compared to resistive detection tape or paper-absorbing type. Simply dry the detection surface and re-install it back.
- PFA material can be used, suitable for acid, alkali, liquid medicine, pure water, and other liquids.
- The product has an indicator light, which can immediately signal the action status.
- Complete output type selection, NPN or PNP type.
- Comply with IP67.
- Comply with lead-free standards and CE certified.



Operating temp.	-20 ~ 80 °C (no freezing)
Working humidity	30 ~ 85%RH (no freezing)
Storage temperature	-40 ~ 80 °C (no freezing)
Storage humidity	30 ~ 85%RH (no freezing)
Protection level	IP67
Connection method	Outlet type, 3-core cable, length 2m or more
Material	Body: PFA. Cable: PFA-coated. Mounting base: PFA.
	PFA: Suitable for acid, alkaline liquid, IPA (isopropanol), pure water. Body: PP. Cable: PVC. Mounting base: PP.
Fixed method	You can choose the configuration according to the material requirements (PP, PFA...etc.)

External Size

(Unit:mm)

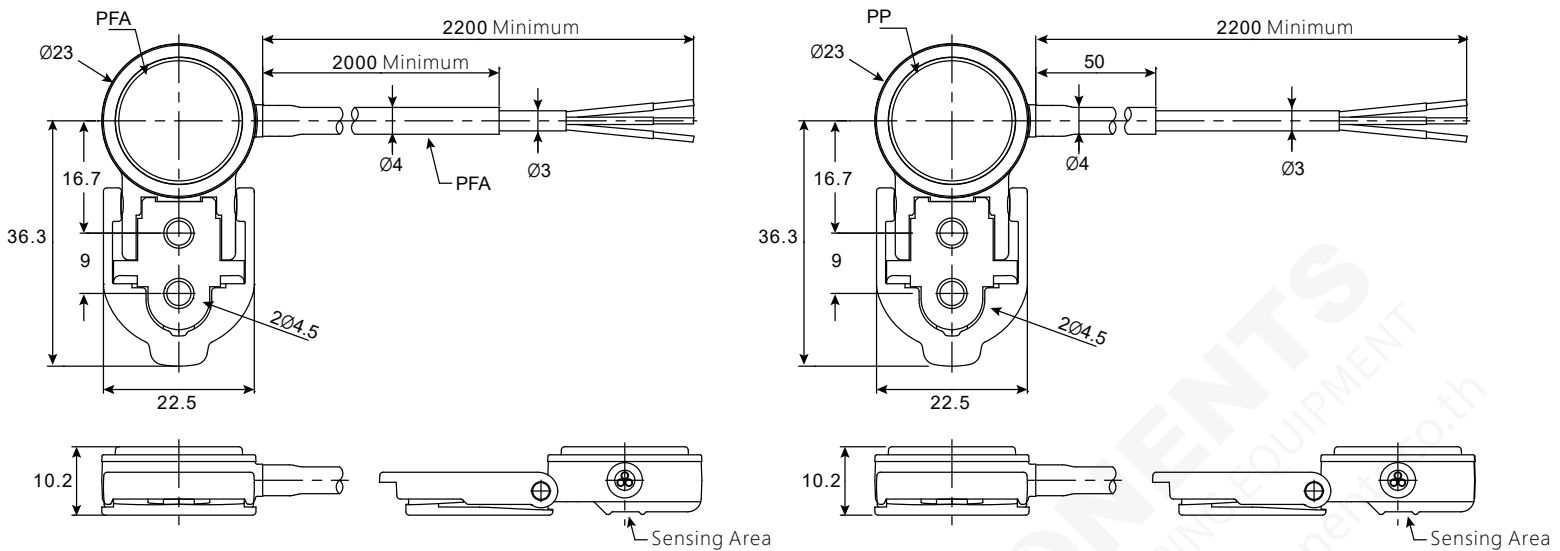

Ordering Instructions

SDL 1 0 0 0 0 - 0

⑩ Output

P: 3-wire PNP, 12~24VDC
N: 3-wire NPN, 12~24VDC

⑪ Contact

A: NO
B: NC

⑫⑬ Body and Mounting Base Material

14: PFA
18: PP

⑭⑮ Cable Cover

00: No coating, cable PVC
14: PFA casing

⑯⑰⑱ Total Length

Code	Cable Length
2200	2200 mm

บริษัท แฟคโต คอมโพเนนส์ จำกัด | FACTO COMPONENTS CO., LTD.

845/3-4 ชั้น 3 ถ.เทพารักษ์ ต.เทพารักษ์ อ.เมือง จ.สมุทรปราการ 10270

TEL. 02-384-5701, 02-753-3652 | LINE OA: @134ovdbx | Website : www.factocomponents.co.th | Email : info@factocomponents.co.th

