

QSC

Flow Control Valve (Precise Type)



Specifications

Model (mm)	QSC-06	QSC-08	QSC-10	QSC-15
Working medium	Clean air(After 40 μm filtration)			
Working Pressure (Mpa)	0.05~1.0			
Guaranteed pressure (Mpa)	1.5			
Working temperature(°C)	-20~70			
Port size ①	1/8"	1/4"	3/8"	1/2"
Standard rated flow	P→A 0~350	0~860	0~1650	0~1900
The amount (L/min)	A→P 300~450	760~890	1320~1650	1610~1990
Weight(g)	33	50	128	119

① G、PT、NPT thread type is optional.

How to Order?

Series No.	Port Size	Thread Type
QSC:Flow control valve (precise type)	06:1/8" 08:1/4" 10:3/8" 15:1/2"	Blank: G P : PT T : NPT

Order Example:

QSC series flow control valve, 1/4" port size, G thread, the ERP code is QSC-08

Product Features

- * Compact structure and high precision
- * Install in several positions to facilitate installation and application
- * Apply to exhaust throttle, widely used for cylinder speed adjustment

Internal Structure

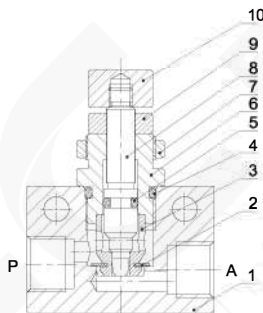

No.	Name
1	Valve body
2	Diaphragm
3	Throttle body
4	O-ring
5	O-ring
6	Throttle sheath
7	Fixed nut
8	Throttle column
9	Lock nut
10	Adjustment cap

Main Dimension

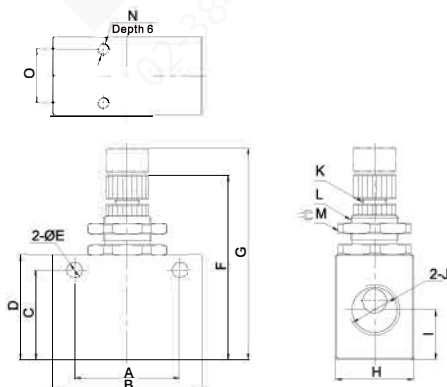

Model	A	B	C	D	E	F	G	H
QSC-06	22	32	20	25	4.3	46	51	15
QSC-08	26	36	23	27	4.3	51	57.5	18
QSC-10	35	50	30	35	5.3	62.5	71.5	26
QSC-15	35	50	30	35	5.3	62.5	71.5	26

Model	I	J	K	L	M	N	O
QSC-06	8.5	1/8	M5X0.25	M12X0.75	14	---	---
QSC-08	13.3	1/4	M6X0.5	M14X1	17	---	---
QSC-10	16.5	3/8	M8X0.75	M16X1	24	M4X0.7	18
QSC-15	16.5	1/2	M8X0.75	M16X1	24	M4X0.7	18

Flow Chart

