



Mass flow controller (MFC)/mass flow meter (MFM) for gases

- Nominal flow ranges from 0.010 l/min to 160 l/min
- High accuracy and repeatability
- Very fast response times
- Simple device exchange due to configuration memory
- Optional: USP Class VI, FDA, EC 1935 compliant

Product variants described in the data sheet may differ from the product presentation and description.

Can be combined with



Type 6013
Plunger valve 2/2-way direct-acting



Type 6027
Direct-acting 2/2-way plunger valve



Type 0330
Direct-acting 2/2 or 3/2-way pivoted armature valve



Type ME43
Fieldbus gateway

Type description

The Type 8741 mass flow controller (MFC)/mass flow meter (MFM) for gases is suitable for a variety of applications and is available with Industrial Ethernet, analogue or fieldbus interfaces. The variant with CANopen-based Bürkert Systembus (büS) is suitable for integration into existing CANopen networks or (in combination with the Type ME43 fieldbus gateway) for integration into all common industry standards for Industrial Ethernet and/or fieldbus. The latter option is tailor-made for applications with many control loops. Up to 32 MFCs/MFMs can be connected to one fieldbus gateway. Type ME43 transmits the internal CANopen-based communication to Industrial Ethernet and fieldbus standards. The mass flow controller/mass flow meter can always switch between büS and CANopen communication. Type 8741 can be configured as an MFM or an MFC according to demand. Furthermore a Modbus RTU variant is available as well. Optionally, up to four calibration curves can be stored in the device. The thermal MEMS sensor is located directly in the gas stream and therefore achieves very fast response times. As actuator, a Bürkert direct-acting proportional valve guarantees high response sensitivity.



Table of contents

1. General technical data	4
2. Approvals and conformities	5
2.1. General notes.....	5
2.2. Conformity	5
2.3. Standards.....	5
2.4. North America (USA/Canada)	5
2.5. Foods and beverages/Hygiene	5
2.6. Oxygen.....	6
3. Materials	6
3.1. Bürkert resistApp	6
4. Dimensions	6
4.1. Thread depths of base blocks	6
MFC/MFM for small nominal flow rates.....	6
MFC/MFM for large nominal flow rates	6
4.2. Variant with büS/CANopen interface	7
MFC with valve Type 2871	7
MFC with valve Type 2873.....	9
MFC with valve Type 2873.....	10
MFM variant.....	11
4.3. Variant with analogue or Industrial Ethernet interface	13
MFC with valve Type 2871	13
MFC with valve Type 2873.....	14
MFC with valve Type 2875.....	15
MFM variant.....	16
4.4. Modbus RTU variant.....	17
5. Device / Process connections	18
5.1. büS/CANopen.....	18
5.2. Industrial Ethernet.....	18
5.3. Analogue.....	19
5.4. Modbus RTU.....	20
6. Performance specifications	20
6.1. MFM pressure loss diagram	20
6.2. Nominal flow range of typical gases.....	21
7. Product operation	21
7.1. Measuring principle.....	21
8. Product accessories	22
8.1. Bürkert Communicator software.....	22
8.2. Connecting Type 8741 with the Bürkert Communicator software.....	23
8.3. Configuration management for easy device replacement	23
8.4. Web server for Industrial Ethernet variant.....	23
9. Ordering information	23
9.1. Bürkert eShop.....	23
9.2. Recommendation regarding product selection.....	23
9.3. Bürkert product filter.....	24

DTS 1000222224 EN Version: AE Status: RL (released | freigegeben | validé) printed: 06.03.2024

9.4. Bürkert Product Enquiry Form24

9.5. Ordering chart accessories.....24



1. General technical data

Product properties	
Dimensions	Further information can be found in chapter "4. Dimensions" on page 6.
Materials	
Seal	FKM or EPDM (depending on gas)
Housing	PC (polycarbonate)
Base block	Aluminium or stainless steel 1.4404/316L
Total weight	Approx. 500 g (aluminium base block)
Configuration management	Further information can be found in chapter "8.3. Configuration management for easy device replacement" on page 23.
LED display ¹⁾	RGB LED according to NAMUR NE107
Performance data	
Nominal flow range (Q _N)	10 ml/min...160 l/min (N ₂)
Maximum operating pressure (overpressure to atmospheric pressure)	MFM: 10 bar For MFCs, the maximum operating pressure depends on the medium and nominal valve size
Measuring accuracy ²⁾	±0.8 % of reading ±0.3 % FS (under calibration conditions)
Repeatability	±0.1 % FS
Measuring span	1:50, optional 1:100
Settling time (MFC)/Response time (MFM) (t _{95%})	<300 ms
Control valve (proportional valve)	
	Normally closed
Valve orifice	0.05...8 mm
K _{vs} value range	0.00006...1.1 m ³ /h
Electrical data	
Operating voltage	24 V DC
Power consumption ³⁾	1...3 W (as MFM) Max. 3...19.5 W (as MFC, depending on type of solenoid control valve)
Residual ripple	±2 %
Voltage tolerance	±10 %
Electrical connection	
büS/CANopen variant	Terminal block, 4-pin
Analogue variant	D-Sub 9 ⁴⁾ or terminal block, 6-pin
Industrial Ethernet variant	2 x RJ45 (switch) ⁵⁾
Modbus RTU variant	D-Sub, 9-pin
Medium data	
Operating medium	Neutral, pure gases (others on request)
Calibration medium	Operating medium or air
Medium temperature	-10 °C...+70 °C (-10 °C...+60 °C with oxygen)
Process/Port connection & communication	
Analogue interface	4...20 mA, 0...20 mA, 0...10 V or 0...5 V Input impedance >20 kΩ (voltage) resp. <300 Ω (current) Maximum current: 10 mA (voltage output) Maximum load: 600 Ω (current output)
Digital communication interface	büS/CANopen, Modbus RS485/RTU list 0 and list 1, Industrial Ethernet: EtherCAT®, EtherNet/IP, Modbus TCP, PROFINET
Port connection	NPT ¼, G ¼, sub-base, compression fitting or vacuum fitting (others on request)
Approvals and conformities	
Protection class	IP20
Material certificate	Material certificate 3.1 (on request)
North America (USA/Canada)	Further information can be found in chapter "2.4. North America (USA/Canada)" on page 5.
Foods and beverages/Hygiene	Further information can be found in chapter "2.5. Foods and beverages/Hygiene" on page 5.
Oxygen	Further information can be found in chapter "2.6. Oxygen" on page 6.
Environment and installation	
Installation position	Horizontal or vertical
Ambient temperature	-10...+50 °C (higher temperatures on request)

Accessories

Software Bürkert Communicator
 Detailed information can be found in chapter “8.1. Bürkert Communicator software” on page 22.

- 1.) For a detailed description of LED colours see **operating instructions Type 8741** ▶
- 2.) If the operating medium is different from the calibration medium, the actual measurement accuracy might vary from the indicated value. If the operating medium is natural gas, the measurement accuracy depends on the composition of the natural gas, which can vary depending on the origin and season.
- 3.) Information in relation to the typical power consumption (at +23 °C ambient temperature, nominal flow and 30 min closed-loop control mode). Information according to UL 61010-1 may vary (see **operating instructions Type 8741** ▶).
- 4.) An additional digital input and a relay output are available for the analogue variant with D-Sub 9.
- 5.) Supply voltage via separate terminal block

2. Approvals and conformities

2.1. General notes

Note:

- The approvals and conformities listed below must be stated when making enquiries. This is the only way to ensure that the product complies with all required specifications.
- Not all available variants can be supplied with the below mentioned approvals or conformities.

2.2. Conformity

In accordance with the Declaration of Conformity, the product is compliant with the EU Directives.

2.3. Standards

The applied standards which are used to demonstrate compliance with the EU Directives are listed in the EU-Type Examination Certificate and/or the EU Declaration of Conformity.

2.4. North America (USA/Canada)

Approval	Description
	<p>Optional: UL Listed for the USA and Canada The products are UL Listed for the USA and Canada according to:</p> <ul style="list-style-type: none"> • UL 61010-1 (ELECTRICAL EQUIPMENT FOR MEASUREMENT, CONTROL, AND LABORATORY USE – Part 1: General Requirements) • CAN/CSA-C22.2 No. 61010-1

2.5. Foods and beverages/Hygiene

Conformity	Description
	<p>FDA – Code of Federal Regulations (valid for variable code PL02, PL03) All wetted materials are compliant with the Code of Federal Regulations published by the FDA (Food and Drug Administration, USA) according to the manufacturer’s declaration.</p>
	<p>United States Pharmacopeial Convention (USP) (valid for variable code PL04) All wetted materials are biocompatible according to the manufacturer’s declaration.</p>
	<p>EC Regulation 1935/2004 of the European Parliament and of the Council (valid for variable code PL01, PL02) All wetted materials are compliant with EC Regulation 1935/2004/EC according to the manufacturer’s declaration.</p>

DTS 1000222224 EN Version: AE Status: RL (released | freigegeben | validé) printed: 06.03.2024

2.6. Oxygen

Conformity	Description
O ₂	Optional: Suitability for oxygen (valid for the variable code NL02) The products are suitable for use with gaseous oxygen, according to the manufacturer's declaration.

3. Materials

3.1. Bürkert resistApp

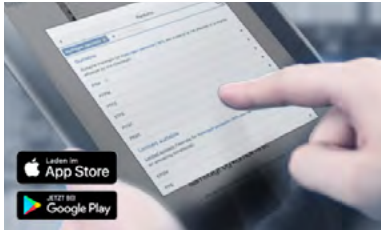

Bürkert resistApp – Chemical Resistance Chart

You want to ensure the reliability and durability of the materials in your individual application case? Verify your combination of media and materials on our website or in our resistApp.

[Start Chemical Resistance Check](#)

4. Dimensions

4.1. Thread depths of base blocks

MFC/MFM for small nominal flow rates

Note:

The following table applies to base blocks C0...C4.

Thread (A)	Thread depth [mm]
G ¼	12
NPT ¼	12
G ⅜	12
NPT ⅜	12

MFC/MFM for large nominal flow rates

Note:

The following table applies to base block C5.

Thread (A)	Thread depth [mm]
G ¼	12
NPT ¼	11
G ⅜	12
NPT ⅜	11
G ½	15
NPT ½	14
G ¾	16
NPT ¾	15

4.2. Variant with büS/CANopen interface

MFC with valve Type 2871

Variant with base block C0...C4 for small nominal flow rates

Note:

Dimensions in mm

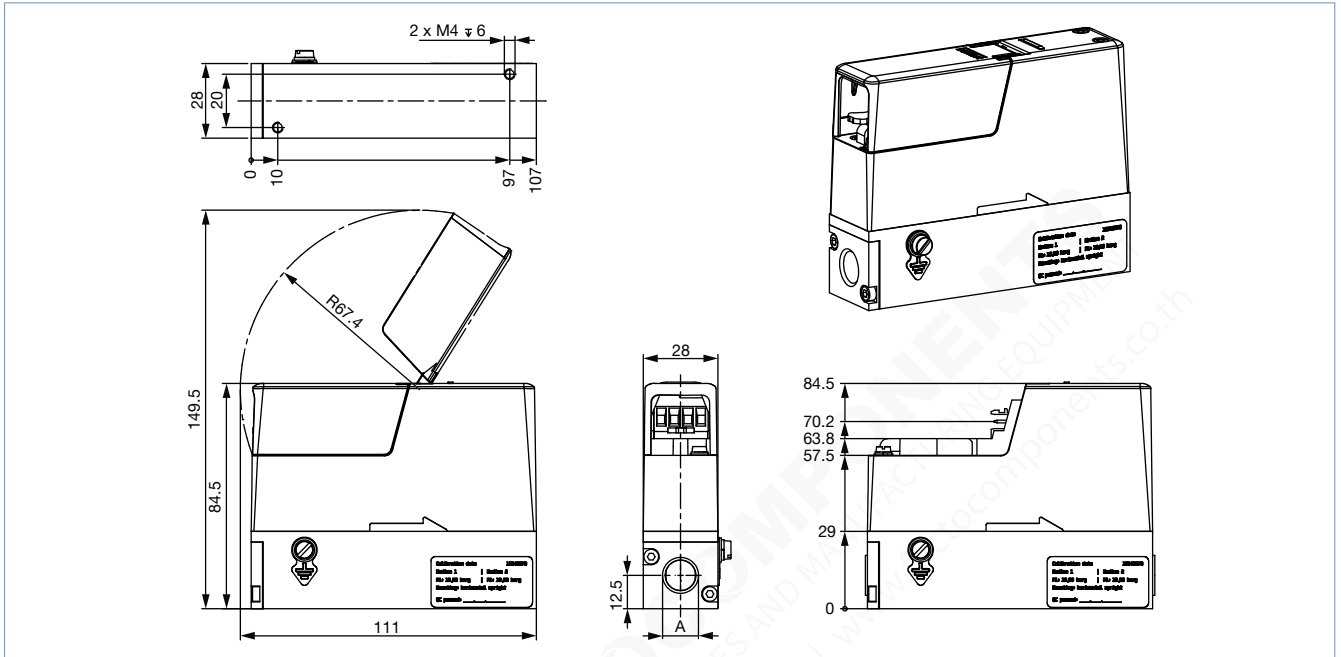

DTS 1000222224 EN Version: AE Status: RL (released | freigegeben | validé) printed: 06.03.2024

Sub-base variant

Note:
Dimensions in mm

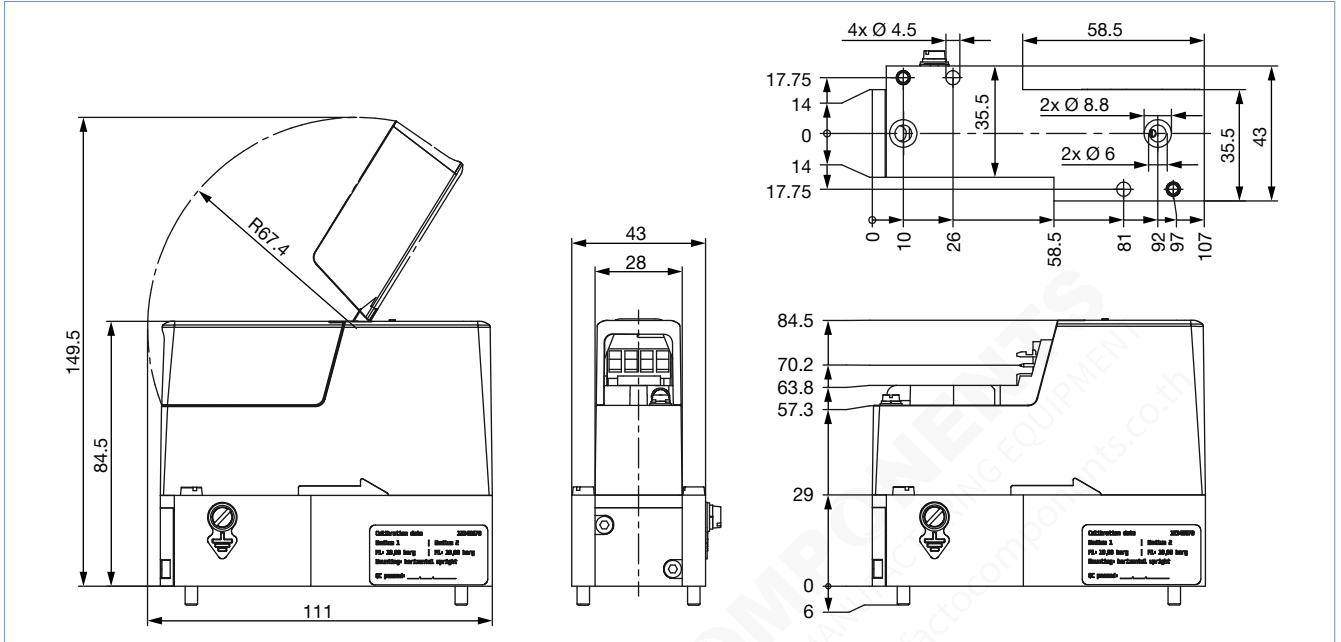

DTS 1000222224 EN Version: AE Status: RL (released | freigegeben | validé) printed: 06.03.2024

FAC FACTOCOMPONENTS INDUSTRIAL SUPPLIES AND EQUIPMENT
02-384-6060 | info@factocomponents.co.th | www.factocomponents.co.th

MFC with valve Type 2873

Variant with base block C...C4 for small nominal flow rates

Note:

Dimensions in mm

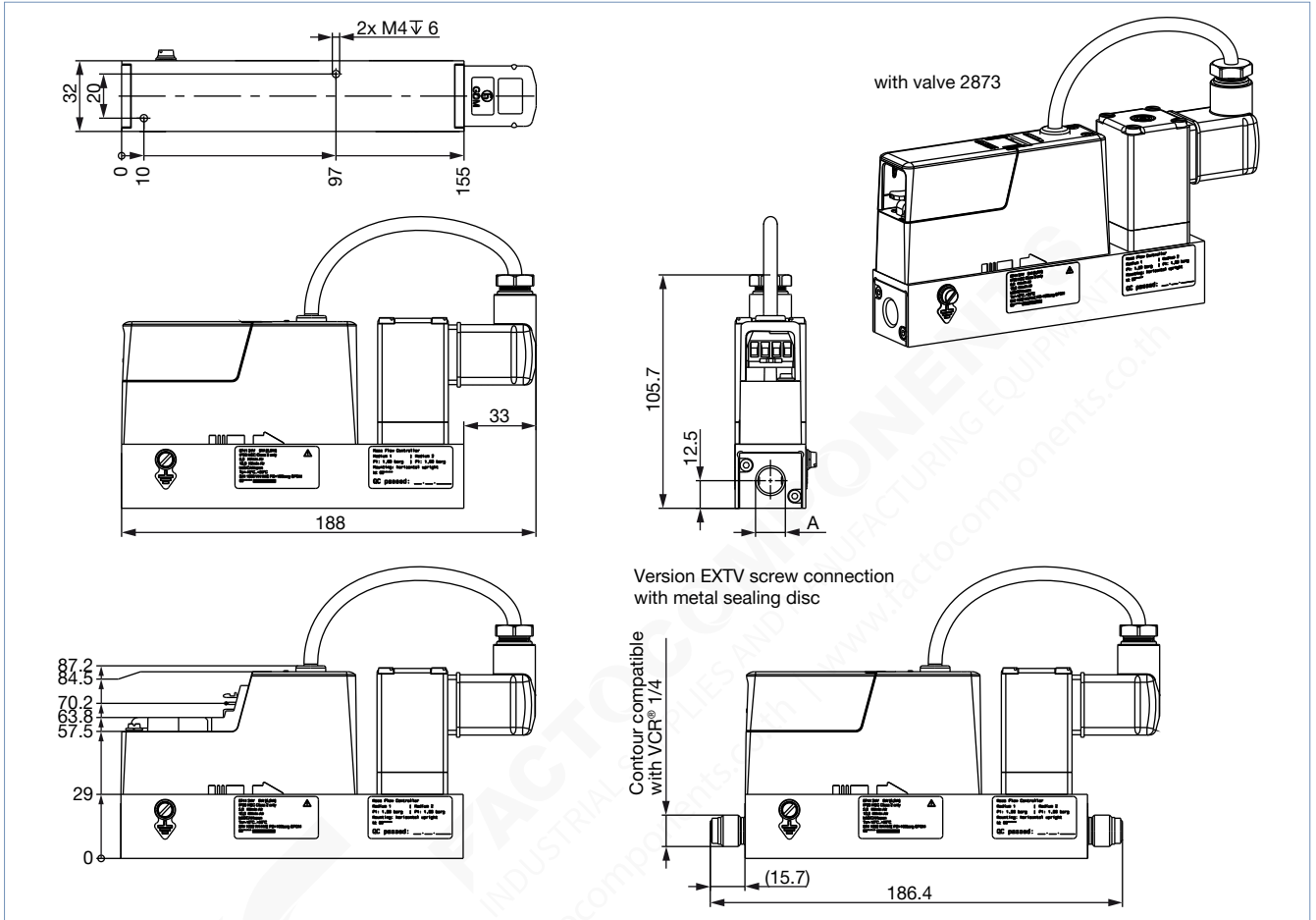

DTS 1000222224 EN Version: AE Status: RL (released | freigegeben | validé) printed: 06.03.2024

Variant with base block C5 for large nominal flow rates

Note:
Dimensions in mm

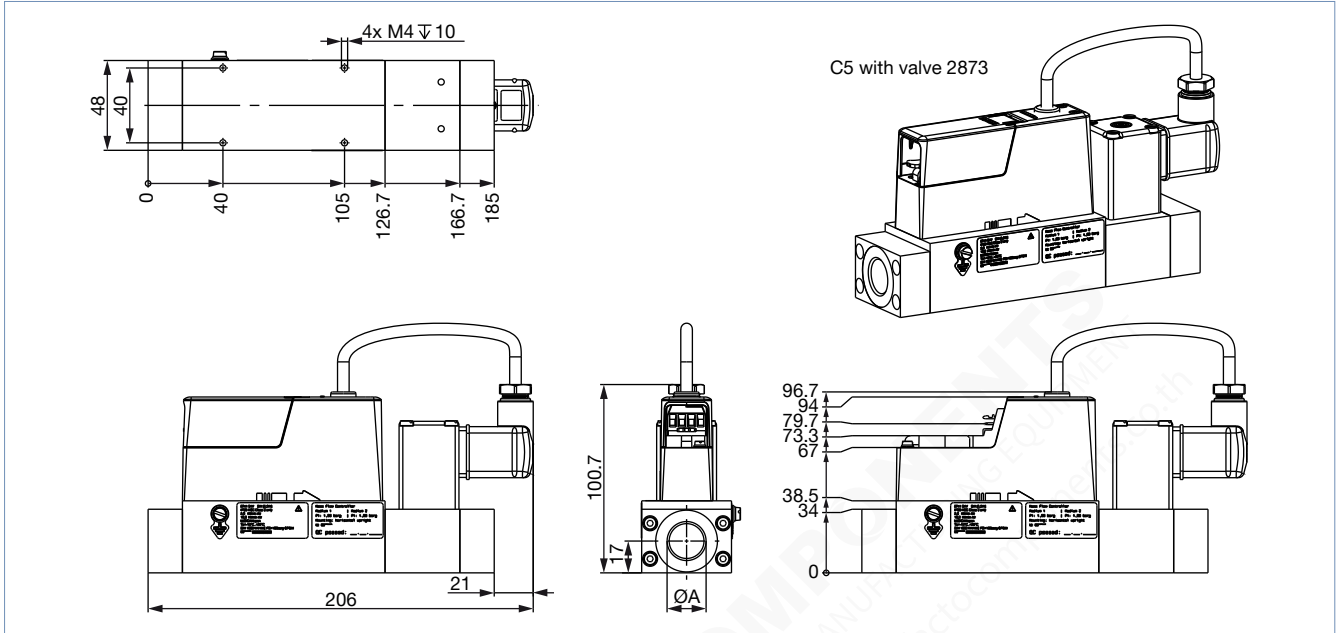

MFC with valve Type 2873

Variant with base block C5 for large nominal flow rates

Note:
Dimensions in mm

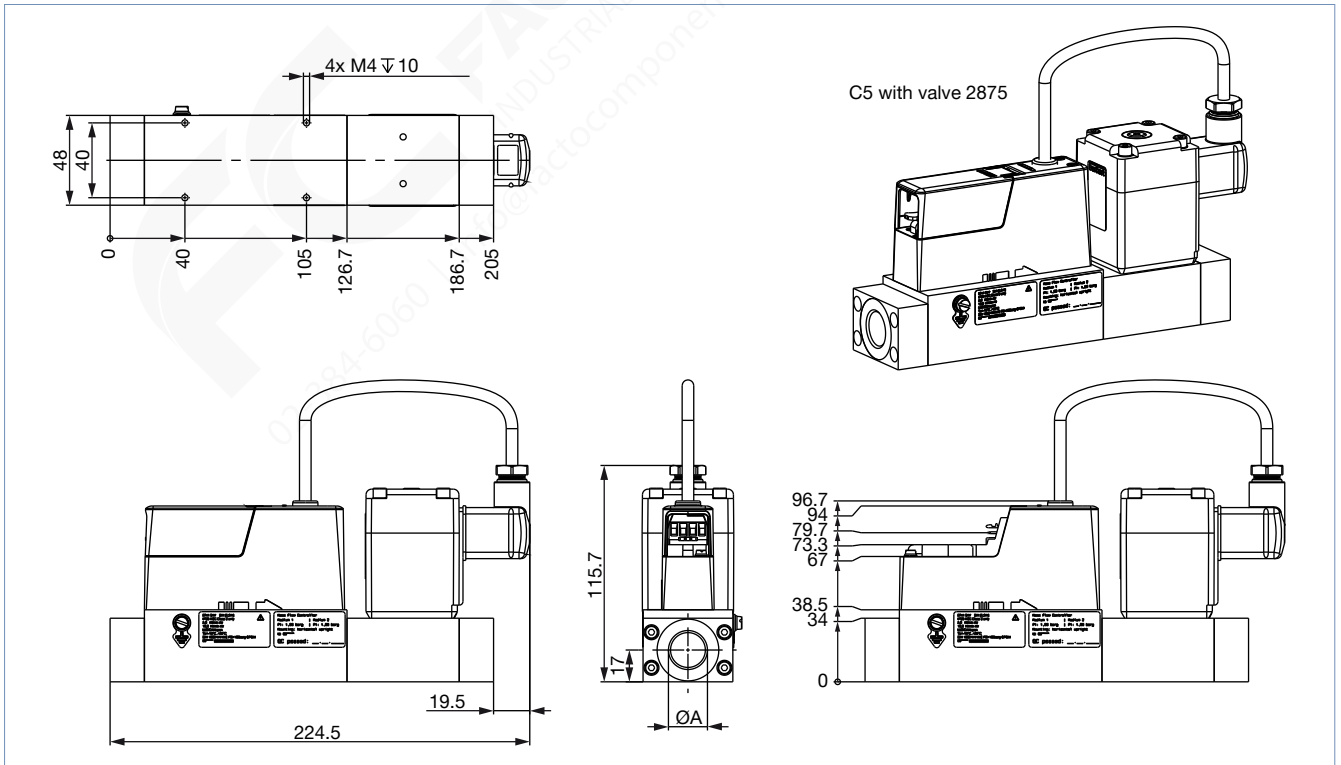

DTS 1000222224 EN Version: AE Status: RL (released | freigegeben | valide) printed: 06.03.2024

MFM variant

Variant with base block C...C4 for small nominal flow rates

Note:

Dimensions in mm

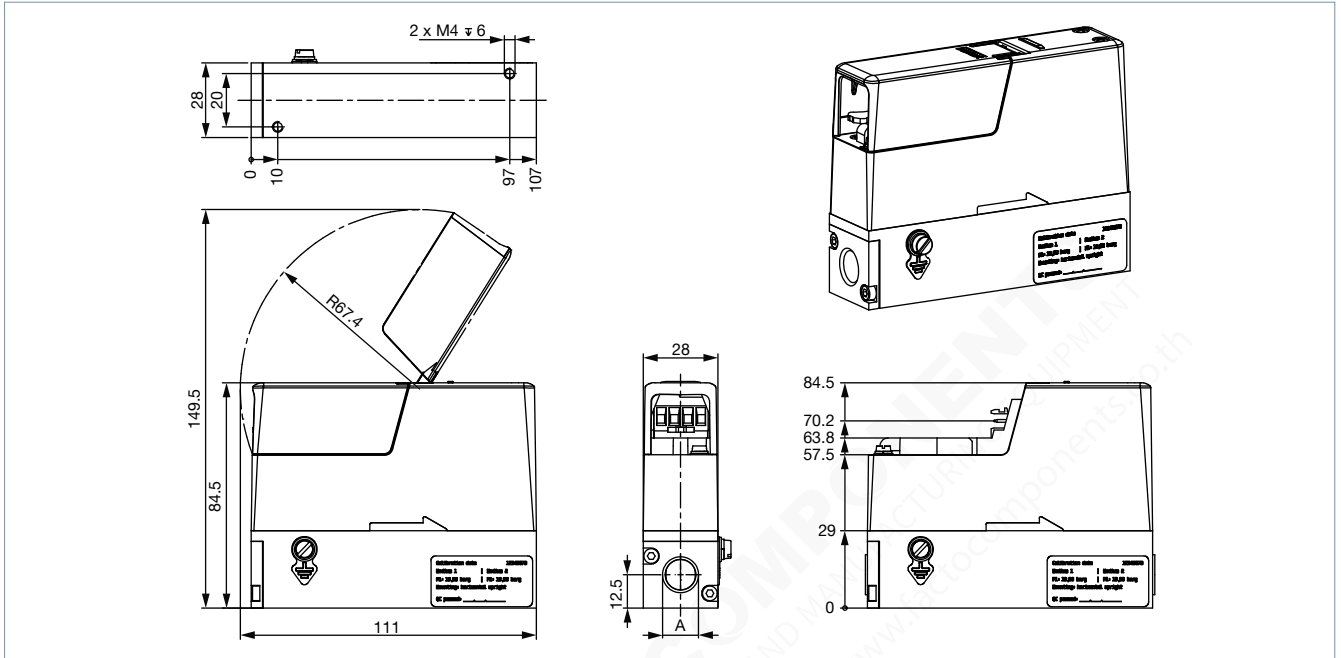

Sub-base variant

Note:

Dimensions in mm

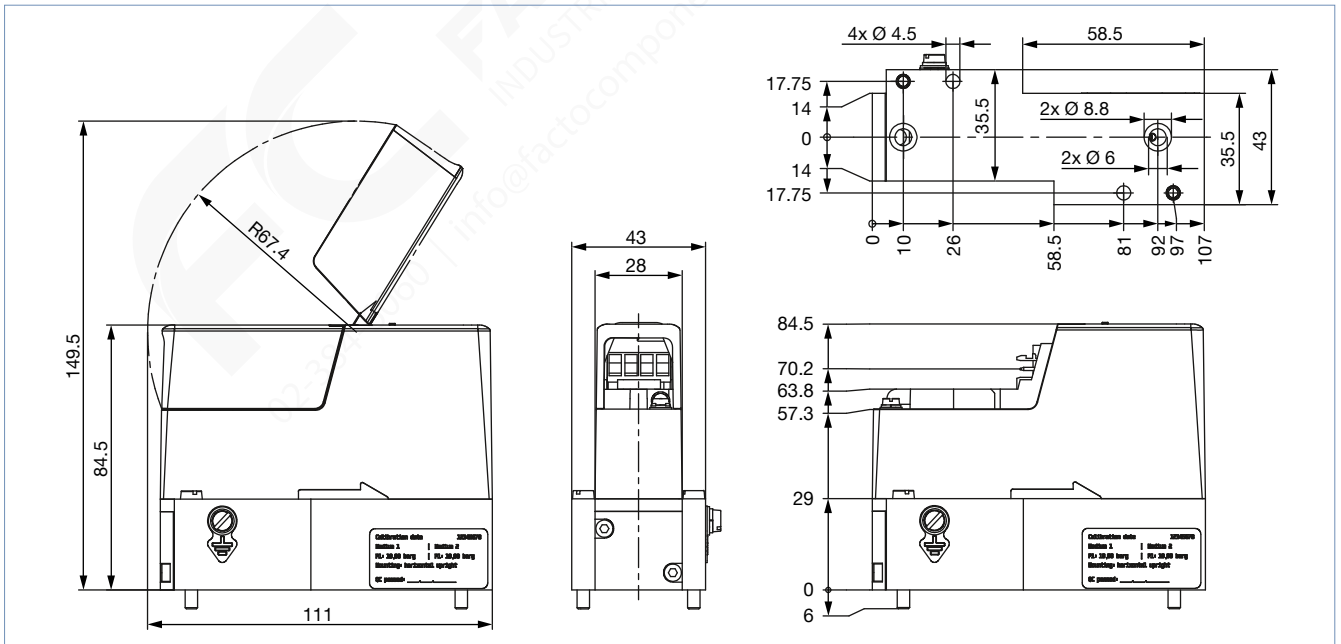

DTS 1000222224 EN Version: AE Status: RL (released | freigegeben | validé) printed: 06.03.2024

Variant with base block C5 for large nominal flow rates

Note:

Dimensions in mm

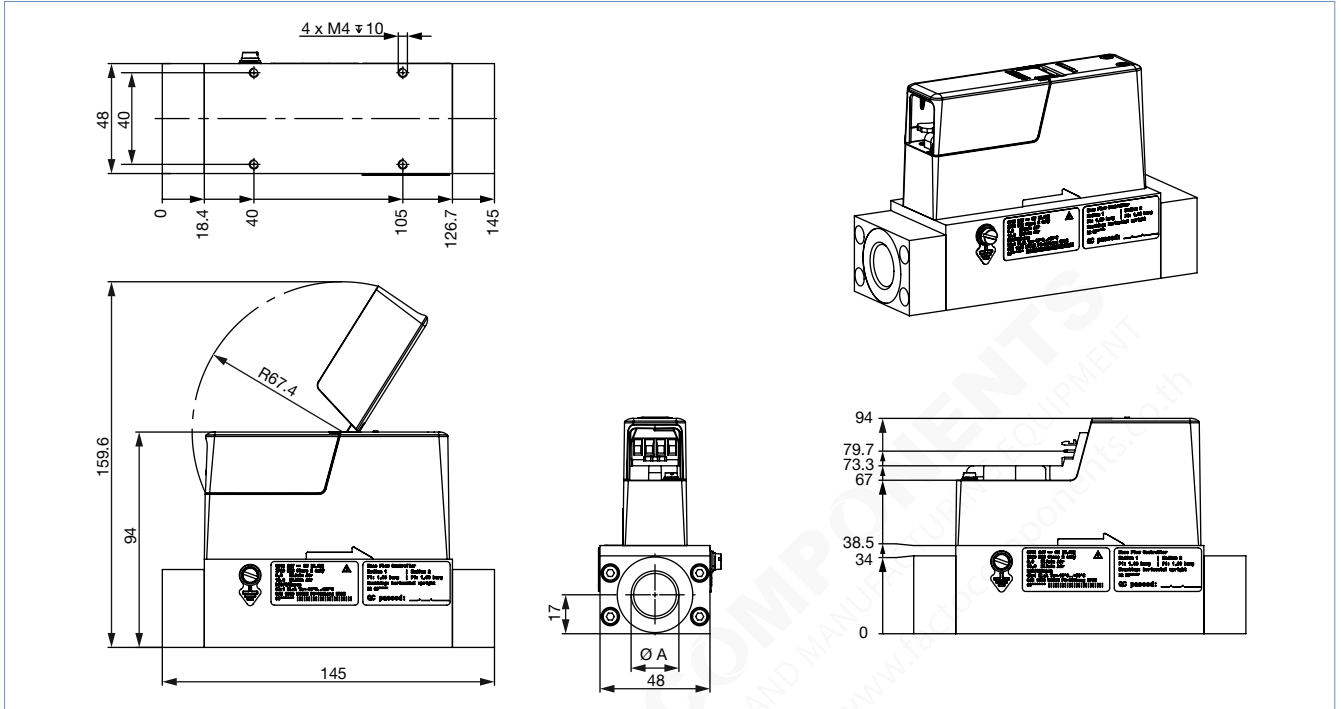

DTS 1000222224 EN Version: AE Status: RL (released | freigegeben | valide) printed: 06.03.2024

FACTOCOMPONENTS

INDUSTRIAL SUPPLIES AND MANUFACTURING EQUIPMENT

02-384-6060 | info@factocomponents.co.th | www.factocomponents.co.th

MFC with valve Type 2873

Variant with base block C0...C4 for small nominal flow rates

Note:

Dimensions in mm

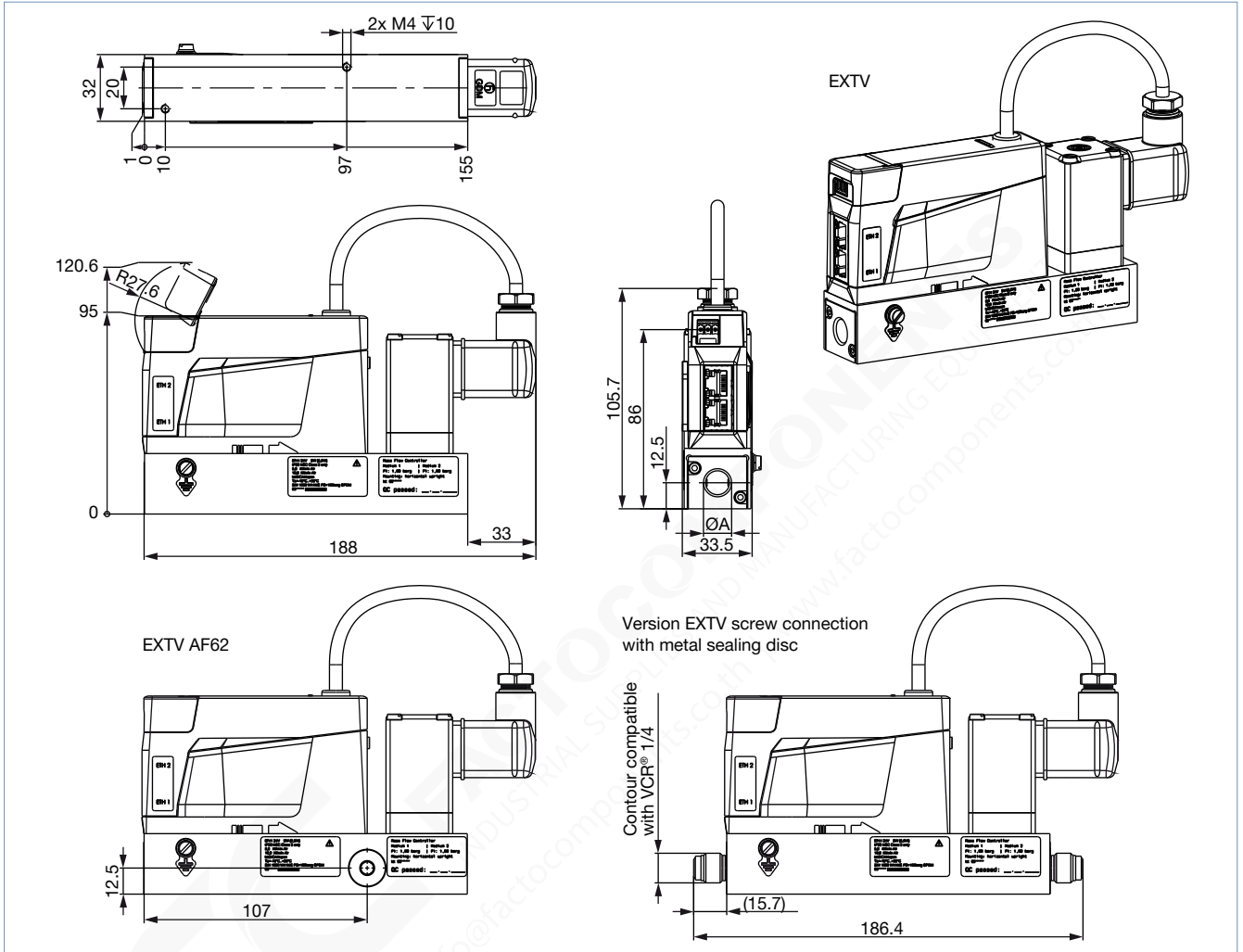

DTS 1000222224 EN Version: AE Status: RL (released | freigegeben | validé) printed: 06.03.2024

Variant with base block C5 for large nominal flow rates

Note:
Dimensions in mm

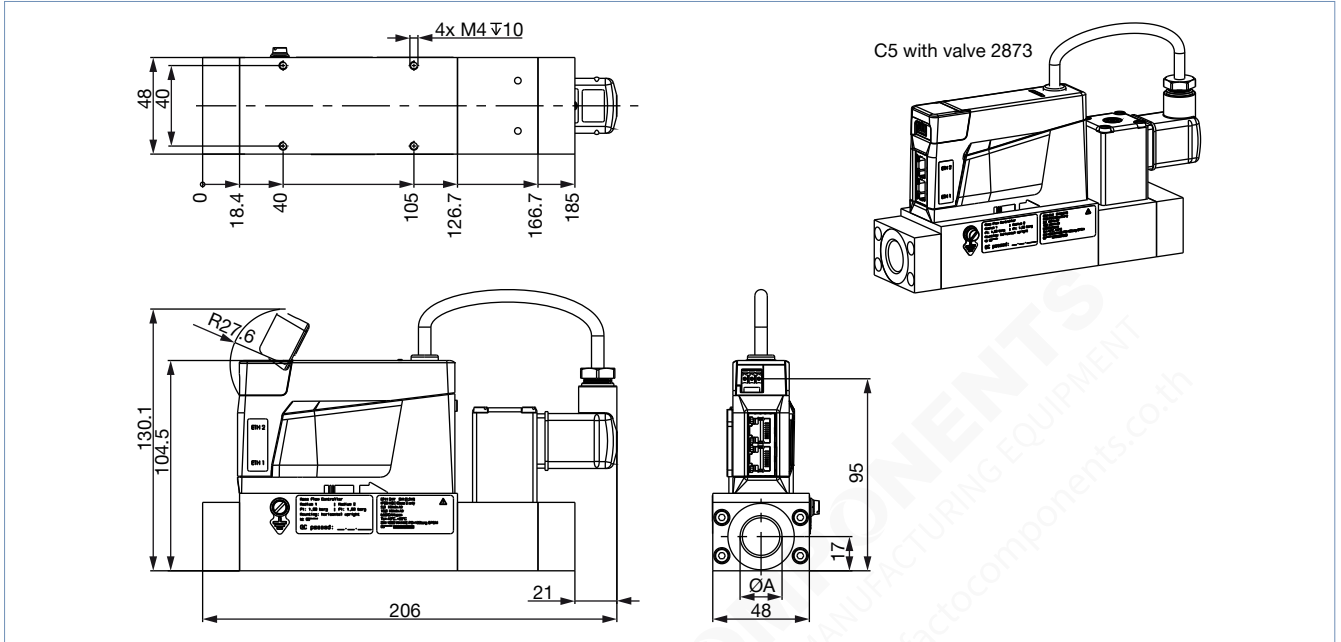

MFC with valve Type 2875

Variant with base block C5 for large nominal flow rates

Note:
Dimensions in mm

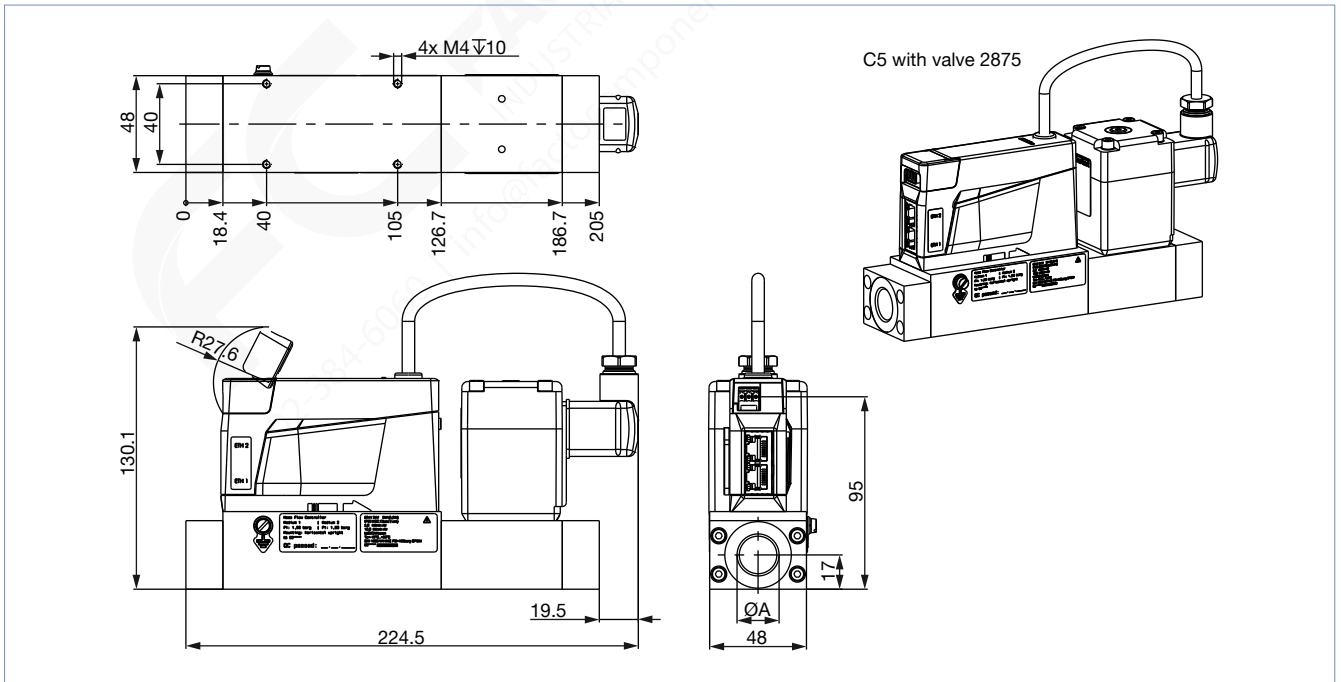

DTS 1000222224 EN Version: AE Status: RL (released | freigegeben | valide) printed: 06.03.2024

MFM variant

Variant with base block C0...C4 for small nominal flow rates

Note:

Dimensions in mm

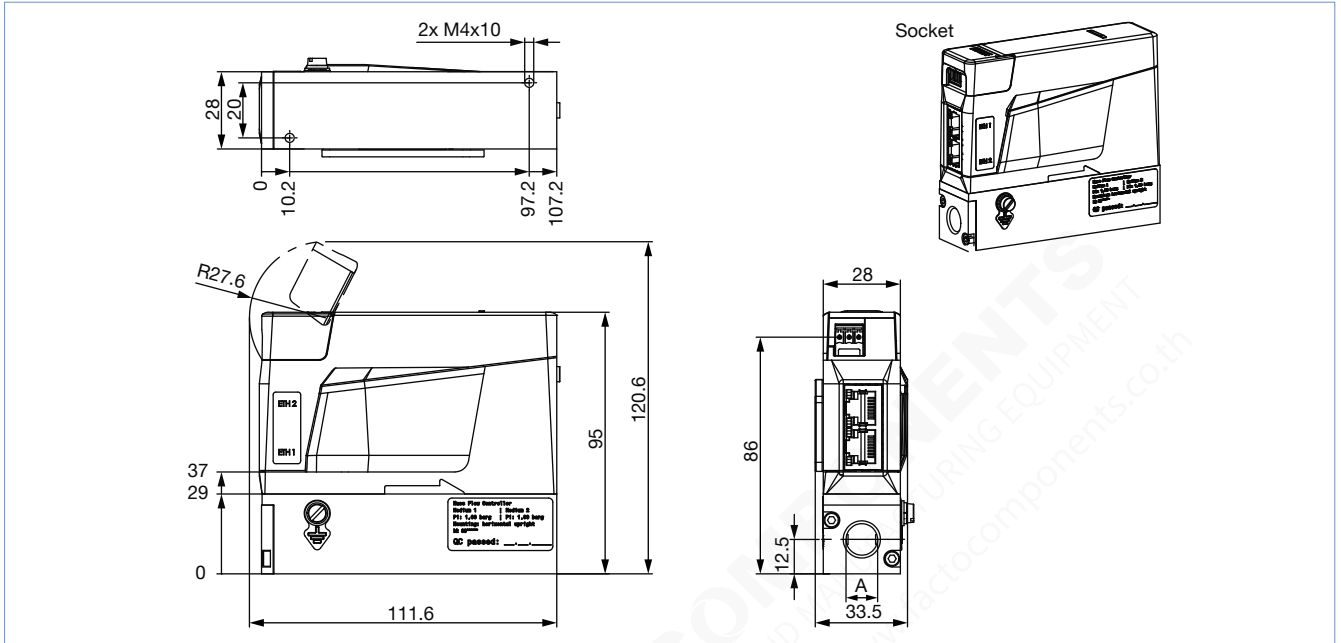

Sub-base variant

Note:

Dimensions in mm

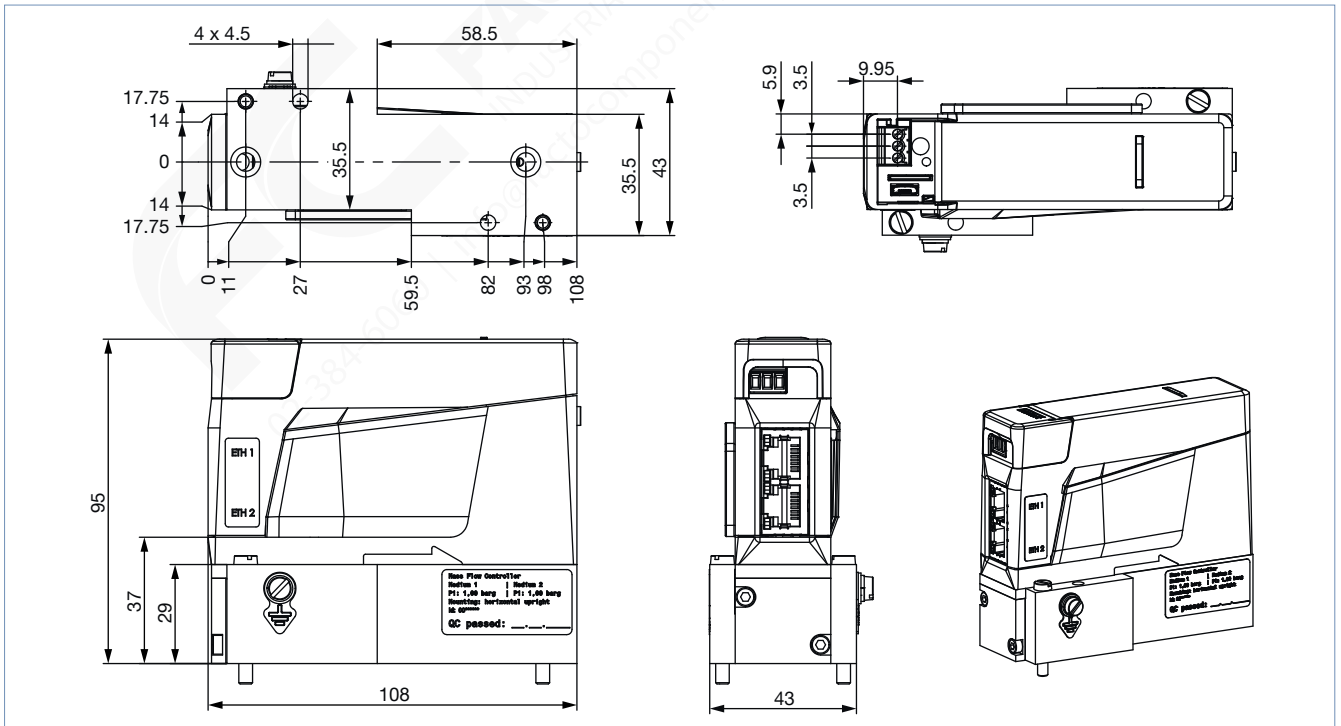

DTS 1000222224 EN Version: AE Status: RL (released | freigegeben | validé) printed: 06.03.2024

Variant with base block C5 for large nominal flow rates

Note:
Dimensions in mm

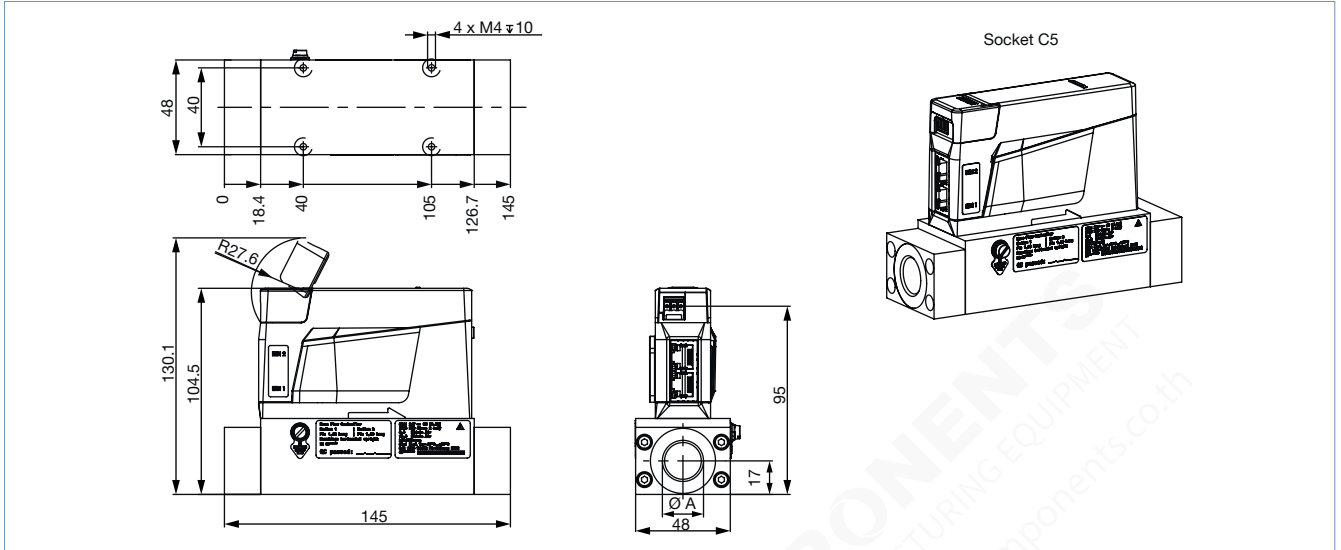

4.4. Modbus RTU variant

Note:
Dimensions in mm

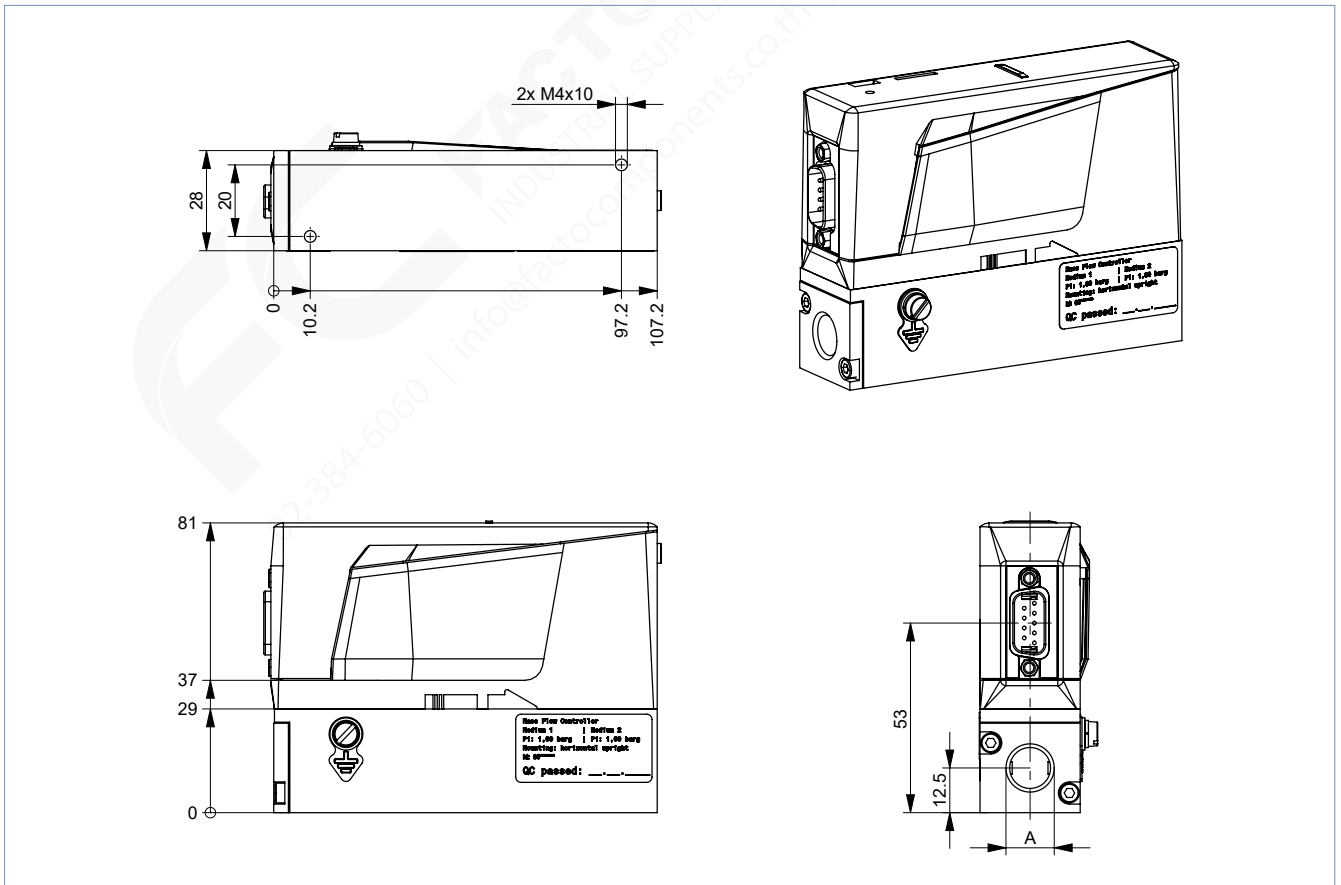

DTS 1000222224 EN Version: AE Status: RL (released | freigegeben | validé) printed: 06.03.2024

5. Device / Process connections

5.1. bÜS/CANopen

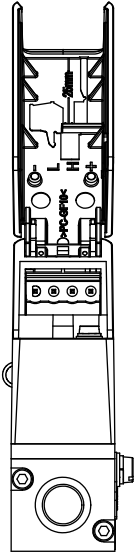

Terminal block, 4-pin	Pin	Assignment
	1	DGND
	2	CAN_L
	3	CAN_H
	4	24 V

Screw M3	Assignment
	When using Bürkert bÜS cables, the following colour coding applies: <ul style="list-style-type: none"> • Red: 24 V • Blue: CAN_L • White: CAN_H • Black: GND

5.2. Industrial Ethernet

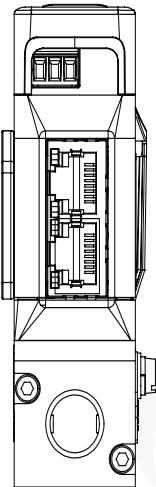

Terminal block, 3-pin	Pin	Assignment
	1	FE (functional earth)
	2	DGND
	3	24 V

RJ45 socket	Pin	Assignment
	1	TX +
	2	TX -
	3	RX +
	4	Not connected
	5	Not connected
	6	RX -
	7	Not connected
	8	Not connected
Housing		Shielding

DTS 1000222224 EN Version: AE Status: RL (released | freigegeben | validé) printed: 06.03.2024

5.3. Analogue

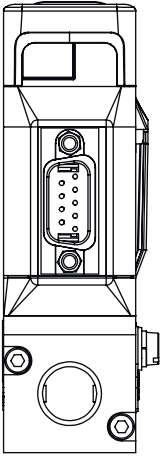

D-Sub, 9-pin, plug		Pin	Assignment
	1	1	Digital input
	2	2	GND (for supply voltage and digital input)
	3	3	24 V
	4	4	Relay, normally closed contact
	5	5	Relay, reference contact
	6	6	Set-point value input +
	7	7	Set-point value input GND
	8	8	Actual value output +
	9	9	Actual value output GND
Housing			Shielding

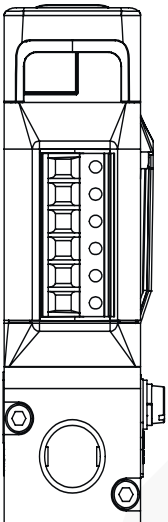

Terminal block, 6-pin		Pin	Assignment
	1	1	24 V
	2	2	GND
	3	3	Set-point value input +
	4	4	Set-point value input GND
	5	5	Actual value output +
	6	6	Actual value output GND

DTS 1000222224 EN Version: AE Status: RL (released | freigegeben | validé) printed: 06.03.2024

5.4. Modbus RTU

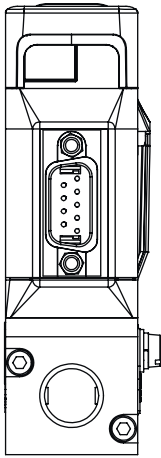

D-Sub, 9-pin, plug		Pin	Assignment
		1	Not connected
		2	GND
		3	24 V
		4	Not connected
		5	Not connected
		6	RS485-Y
		7	RS485-Z
		8	RS485-B
		9	RS485-A
Housing			Shielding

6. Performance specifications

6.1. MFM pressure loss diagram

The diagram shows an example of the pressure loss characteristics when air flows through. To determine the pressure loss of other gases, the corresponding air equivalent must first be calculated and the base block used for the other gas taken into account.

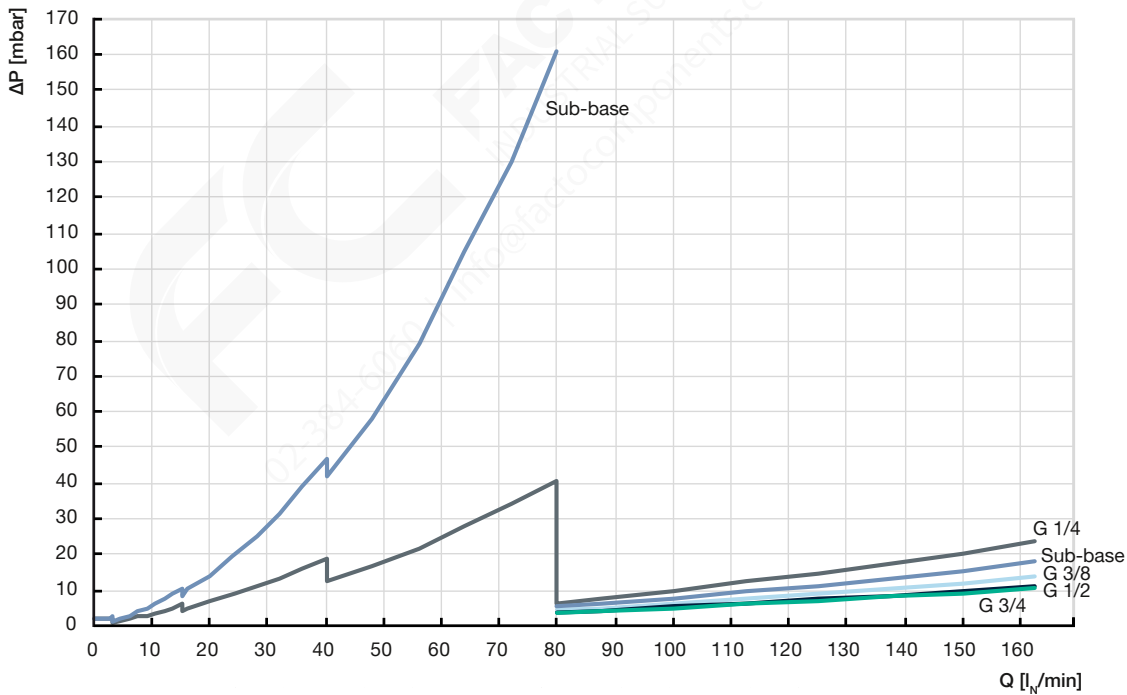

DTS 1000222224 EN Version: AE Status: RL (released | freigegeben | validé) printed: 06.03.2024

6.2. Nominal flow range of typical gases

Note:

- All values refer to 1013.25 mbar abs and 273.15 K (0 °C) (Index N)
- Other gases and gas mixtures are possible on request.

Gas	Min. Q_N [l/min]	Max. Q_N [l/min]
Acetylene	0.01	65
Helium	0.01	1000
Carbon dioxide	0.02	80
Air	0.01	160
Methane	0.01	160
Oxygen	0.01	160
Nitrogen	0.01	160
Hydrogen	0.01	1000
Propane	0.03	44

7. Product operation

7.1. Measuring principle

Measurement takes place via bypass. A laminar flow element (LFE) in the main channel creates a low pressure drop. A part of the gas flow is thereby directed into a side channel. A sensor measures the mass flow as temperature difference. The measurement is performed in a specially shaped flow channel whose wall contains a Si chip with an etched membrane. A heating resistor and 2 temperature sensors, one upstream and one downstream, are placed on this membrane.

If the heating resistor is fed with a constant voltage, the differential voltage of the temperature sensors indicate the gas flow over the chip.

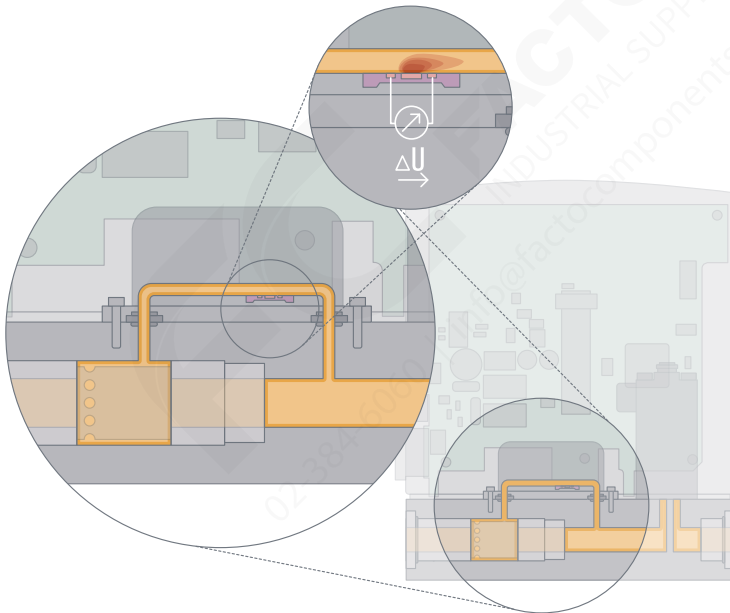

8. Product accessories

8.1. Bürkert Communicator software

Note:

The corresponding communication software can be downloaded from the website [Type 8920](#) ▶.

The Bürkert Communicator is the most important software component of the EDIP (Efficient Device Integration Platform). Various features of this universal tool simplify the configuration and parametrisation of devices equipped with a digital CANopen-based interface. With this tool, the user has a complete overview of cyclic process values as well as acyclic diagnostic data. The integrated graphical programming environment enables the creation of decentralised sub-system control functions. The connection to the PC is established with a USB bus interface set. The adapter is available as an accessory (see [“9.5. Ordering chart accessories”](#) on page 24).

The Bürkert Communicator enables:

- Configuration, parametrisation and diagnosis of EDIP devices / networks
- Switching between defined gases
- Easy and comfortable mapping of cyclic values
- Graphic display, monitoring and storage of process values
- Firmware update of the connected EDIP devices
- Saving and restoring device configurations
- Zero-point adjustment in case of changed ambient conditions
- Guided re-calibration routine

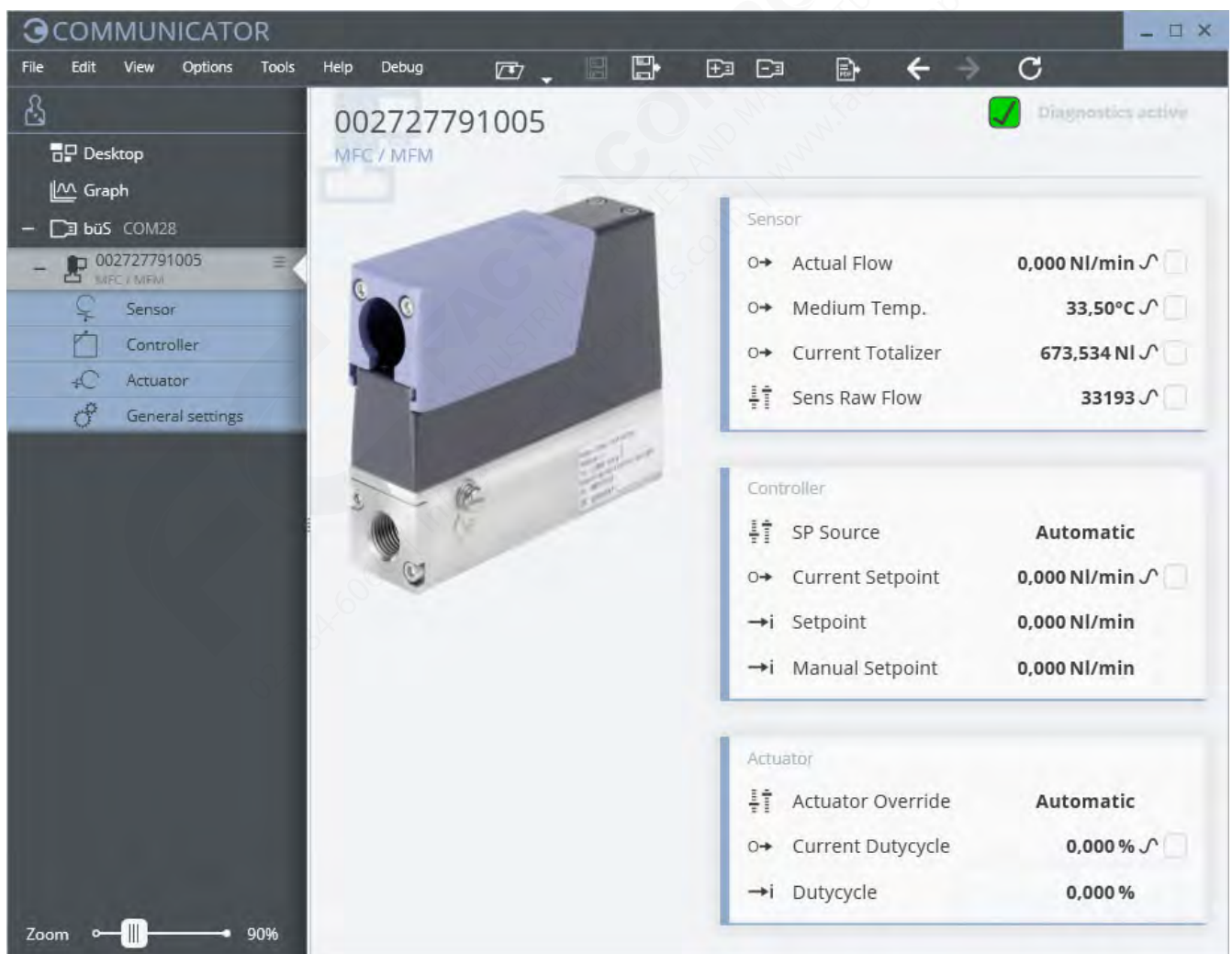

8.2. Connecting Type 8741 with the Bürkert Communicator software

The Bürkert Communicator software interface is based on CANopen. The appropriate bus termination is mandatory. For Type 8741 Analogue, Industrial Ethernet or Modbus RTU, activate the termination resistor switch on the bus stick. For Type 8741 bus/CANopen, the termination resistor must not be activated in case the device is already integrated into a properly terminated bus network.

- For Type 8741 Analogue, Industrial Ethernet or Modbus RTU, the connection is established via the device's micro USB socket (USB bus interface set 2 contains the necessary accessories).
- For Type 8741 bus/CANopen, the connection is established via the 4-pin terminal block (USB bus interface Set 1 contains the required accessories).

Please note: no external power supply must be connected to the micro USB socket. The device must be provided with power as described in chapter "5. Device / Process connections" on page 18.

8.3. Configuration management for easy device replacement

Depending on the electrical connection of the MFC, the following options for device replacement are available:

- If a device needs to be replaced, the memory card can be removed from the defective device and inserted into the new one. This transfers all data of the device to be replaced to the new device. The memory card is available as an accessory and must be ordered separately (see "9.5. Ordering chart accessories" on page 24).
- Option for Type 8741 bus/CANopen: The device is exchanged via the configuration provider of the higher-level gateway control (ME43 or ME63). In the gateway, a memory card is required. The memory card is available as an accessory and must be ordered separately (see "9.5. Ordering chart accessories" on page 24).

In order to successfully exchange the device, it is necessary that both the new device and the device to be replaced possess the same device ID.

8.4. Web server for Industrial Ethernet variant

The Industrial Ethernet-based devices (except for the EtherCAT® protocol) from software version A.13.00.00 dispose of an integrated web server. The server can be accessed via a web browser by entering the device's IP address (factory setting IP192.168.1.100).

9. Ordering information

9.1. Bürkert eShop



Bürkert eShop – Easy ordering and quick delivery

You want to find your desired Bürkert product or spare part quickly and order directly? Our online shop is available for you 24/7. Sign up and enjoy all the benefits.

[Order online now](#)

9.2. Recommendation regarding product selection

Note:

Use the Product Enquiry Form (see "9.4. Bürkert Product Enquiry Form" on page 24) for the device details and send it to us once completed.

For the proper choice of the actuator orifice within the MFC, you need to know not only the required maximum flow rate Q_N but also the pressure values directly before and after the MFC (p_1, p_2) at Q_N . In general, these pressures are not the same as the overall inlet and outlet pressures of the whole plant, because usually, additional flow resistors (tubing, additional shut-off valves, nozzles etc.) are present both before and after the MFC.

Please use the Product Enquiry Form to indicate the pressures directly before and after the MFC. If these are unknown or not accessible to measurement, estimates are to be made by taking into account the approximate pressure drops over the flow resistors before and after the MFC, at Q_N flow rate. In addition, please quote the maximum inlet pressure p_{1max} to be encountered. This data is needed to make sure the actuator is able to provide a close-tight function within all the specified modes of operation.

9.3. Bürkert product filter



Bürkert product filter – Get quickly to the right product

You want to select products comfortably based on your technical requirements? Use the Bürkert product filter and find suitable articles for your application quickly and easily.

Try out our product filter

9.4. Bürkert Product Enquiry Form

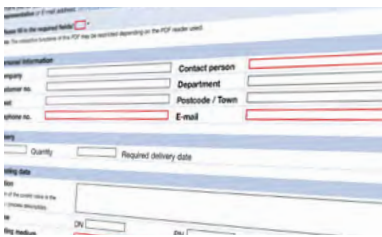

Bürkert Product Enquiry Form – Your enquiry quickly and compactly

Would you like to make a specific product enquiry based on your technical requirements? Use our Product Enquiry Form for this purpose. There you will find all the relevant information for your Bürkert contact. This will enable us to provide you with the best possible advice.

Fill out the form now

9.5. Ordering chart accessories

Description	Article no.
General accessories	
USB bÜS interface set 1 (Type 8923) for connection to the Bürkert Communicator software: includes connection cable (M12 and micro USB), stick with integrated terminating resistor, power supply and software	772426
USB bÜS interface set 2 (Type 8923) for connection to the Bürkert Communicator software: including bÜS stick, connection cable to M12 plug, M12 connection cable on micro USB for the bÜS service interface and Y-distributor, cable length: 0.7 m	772551
Power supply unit Phoenix Class2 (Type 1573), 85...240 V AC/24 V DC, 1.25 A, NEC Class 2 (UL 1310)	772438
Power supply unit for standard rail (Type 1573), 100...240 V AC/24 V DC, 1 A, NEC Class 2 (UL 1310)	772361
Power supply unit for standard rail (Type 1573), 100...240 V AC/24 V DC, 2 A, NEC Class 2 (UL 1310)	772362
Power supply unit for standard rail (Type 1573), 100...240 V AC/24 V DC, 4 A	772363
Memory card	On request
Device description files for software interfaces	Download from Type 8745 ▶
Bürkert Communicator software	Download from Type 8920 ▶
For Type 8741 bÜS/CANopen	
Terminal block 4-pin (included in delivery)	565876
Terminal block 4-pin with integrated 120 Ω resistance for bÜS connection	566066
bÜS cable, 50 m	772413
bÜS cable, 100 m	772414
LabVIEW device driver	On request
For Type 8741 Analogue	
Terminal block 6-pin (standard for 8741, included in delivery of the corresponding analogue variant)	On request
D-sub adapter cable, on strand, cable length: 5 m	580882
D-sub adapter cable, on strand, cable length: 10 m	580883

DTS 1000222224 EN Version: AE Status: RL (released | freigegeben | valide) printed: 06.03.2024