



### FLOWave SAW flowmeter

- No obstacles inside the measuring tube, compact, lightweight and low energy consumption
- Conforms to hygienic requirements, CIP/SIP compatible
- Ideal for liquids with low or no conductivity
- Digital communication, parameterisation via Communicator, display
- Optional: ATEX/IECEX certification, II 3G/D

Product variants described in the data sheet may differ from the product presentation and description.

#### Can be combined with

	<b>Type 8802</b> ELEMENT continuous control valve systems - overview	▶
	<b>Type 8619</b> multiCELL - Multi-channel and multi-function transmitter/controller	▶
	<b>Type 8647</b> AirLINE SP – electropneumatic automation system	▶
	<b>Type ME43</b> Fieldbus gateway	▶

#### Type description

The Type 8098 flowmeter is part of the FLOWave product range. It is based on SAW (Surface Acoustic Waves) technology and is mainly designed for applications with the highest hygienic demands. This is achieved by using suitable stainless steel materials, a measuring tube completely free of any internal parts and an ideal outer hygienic design.

FLOWave offers a range of integrated functions including the advantages of flexibility, ease of cleaning, compact dimensions, lightweight, easy installation and handling, and is compliant with numerous standards.

Optimal measurement results can be achieved with homogeneous liquids, free of air and solid particles. For liquids with high viscosity, an integrated viscosity compensation can be activated. Gas and steam cannot be measured; however, their flow does not have any negative effect on the device or its operation and other liquids flowing through afterwards are measured correctly as before.

Beside volume flow, a density measurement optional feature is available. With this option, the mass flow is calculated based on volume flow and density measurements.

Special functions derived from further process values (differentiation factor (DF), acoustic transmission factor and concentration) offer additional information about the particular liquid in use (for details, see chapter “7.2. Special functions” on page 31).



## Table of contents

<b>1. General technical data</b>	<b>4</b>
1.1. About the device .....	4
1.2. All variants.....	4
1.3. FLOWave L flowmeter.....	9
With or without industrial communication .....	9
With industrial communication (Ethernet variant) .....	11
1.4. FLOWave S flowmeter .....	13
<b>2. Approvals and conformities</b>	<b>14</b>
2.1. General notes.....	14
2.2. Conformity .....	14
2.3. Standards.....	14
2.4. Pressure Equipment Directive (PED).....	15
Device used on a pipe .....	15
2.5. Explosion protection .....	15
2.6. North America (USA/Canada) .....	15
2.7. Foods and beverages/Hygiene .....	16
2.8. Others .....	16
Network protocol .....	16
<b>3. Materials</b>	<b>16</b>
3.1. Bürkert resistApp .....	16
3.2. Material specifications .....	17
FLOWave L flowmeter without industrial communication .....	17
FLOWave L flowmeter with industrial communication.....	18
FLOWave S flowmeter .....	19
<b>4. Dimensions</b>	<b>20</b>
4.1. Transmitter of the FLOWave L flowmeter without industrial communication .....	20
4.2. Transmitter of the FLOWave L flowmeter with industrial communication (Ethernet variant).....	20
4.3. Transmitter of the FLOWave S flowmeter .....	20
4.4. Flowmeter with clamp connection.....	21
4.5. Flowmeter with aseptic collar flange connection (BF) .....	23
4.6. Flowmeter with aseptic collar clamp connection (BKS) .....	24
4.7. Flowmeter with thread connection.....	25
<b>5. Performance specifications</b>	<b>25</b>
5.1. Medium temperature diagram.....	25
5.2. Measurement deviation table.....	26
5.3. Refresh time table .....	27
<b>6. Product installation</b>	<b>27</b>
6.1. Installation notes .....	27
Flow measurement.....	27
6.2. Selection of the nominal diameter .....	28
6.3. Mounting options .....	29
FLOWave L flowmeter.....	29
FLOWave S flowmeter .....	29
<b>7. Product operation</b>	<b>30</b>
7.1. Measuring principle.....	30
7.2. Special functions.....	31

<b>8. Product design and assembly</b>	<b>31</b>
8.1. Product assembly .....	31
<b>9. Product accessories</b>	<b>32</b>
<b>10. Ordering information</b>	<b>32</b>
10.1. Bürkert eShop .....	32
10.2. Recommendation regarding product selection.....	33
10.3. Bürkert product filter.....	33
10.4. Bürkert Product Enquiry Form .....	34
10.5. Bürkert 3D Model.....	34
10.6. Ordering chart FLOWave L flowmeter with or without industrial communication .....	34
Clamp connection acc. to DIN 32676 series A for pipe acc. to DIN 11866 series A (DIN 11850) .....	34
Clamp connection acc. to DIN 32676 series B for pipe acc. to DIN 11866 series B (ISO 1127).....	35
Clamp connection acc. to DIN 32676 series C for pipe acc. to DIN 11866 series C (ASME BPE) .....	36
Thread connection acc. to DIN 11851 series A for pipe acc. to DIN 11866 series A (DIN 11850) .....	37
10.7. Ordering chart FLOWave S flowmeter .....	38
Clamp connection acc. to DIN 32676 series A for pipe acc. to DIN 11866 series A (DIN 11850) .....	38
Clamp connection acc. to DIN 32676 series B for pipe acc. to DIN 11866 series B (ISO 1127).....	39
Clamp connection acc. to DIN 32676 series C for pipe acc. to DIN 11866 series C (ASME BPE) .....	40
Thread connection acc. to DIN 11851 series A for pipe acc. to DIN 11866 series A (DIN 11850) .....	41
10.8. Ordering chart accessories.....	42

DTS 1000270652 EN Version: Y Status: RL (released | freigegeben | validé) printed: 12.04.2024

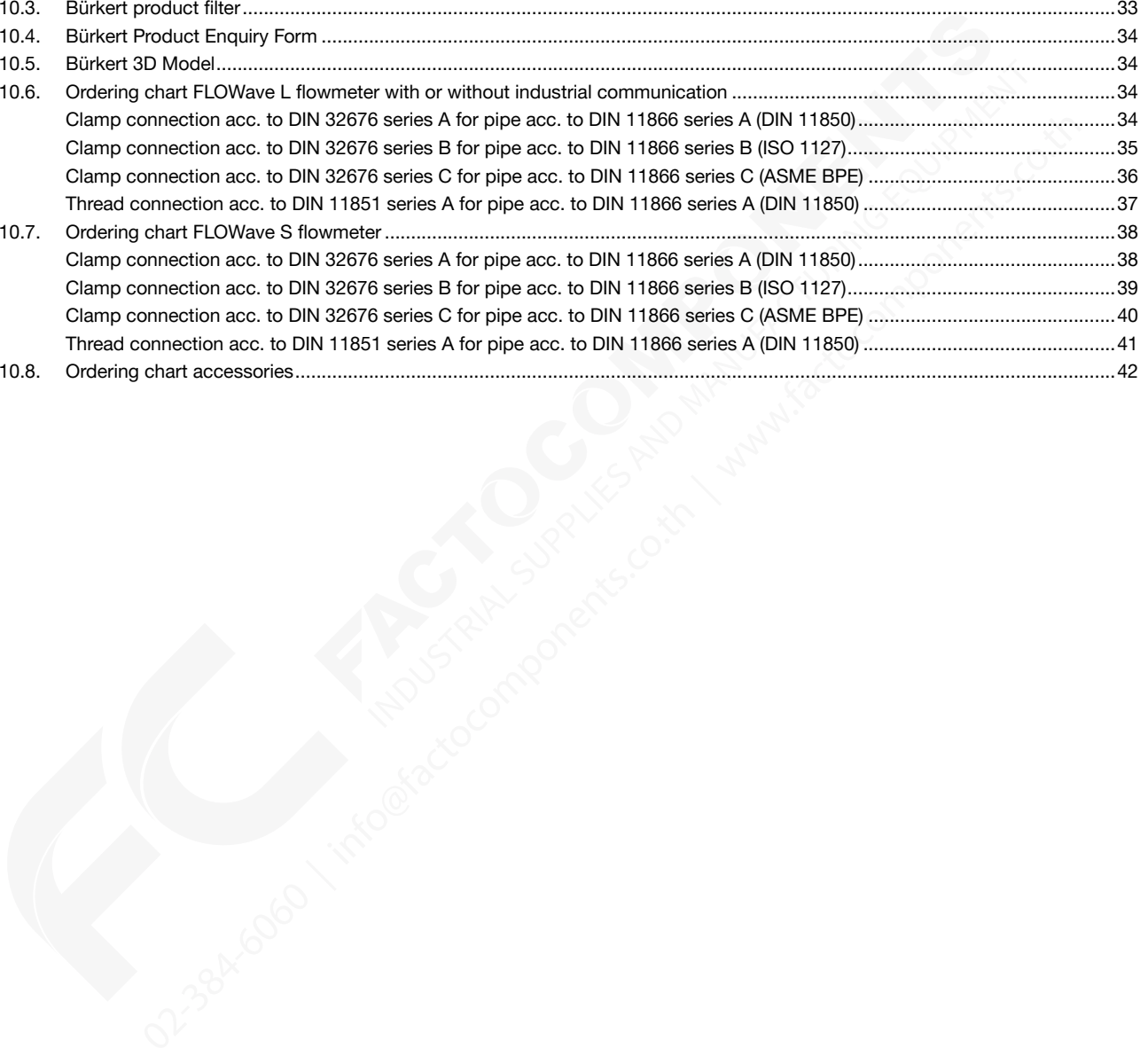

## 1. General technical data

### 1.1. About the device

The flowmeter Type 8098 consists of:

- either a flow sensor Type S097 and a FLOWave L transmitter (variant FLOWave L flowmeter), which is available with or without industrial communication (the FLOWave L variant with industrial communication, recognisable by the two M12 female connectors and the M12 male connector, is called the Ethernet variant.)



- or a flow sensor Type S097 and a FLOWave S transmitter (variant FLOWave S flowmeter)



### 1.2. All variants

**Note:**

- The following data applies to all variants mentioned above.
- In the following table, the term “full scale” refers to full scale of volume flow rate, i.e. the flow rate corresponding to 10 m/s flow velocity.

Product properties	
<b>Material</b>	
Make sure the device materials are compatible with the fluid you are using. Further information can be found in chapter <a href="#">“3.1. Bürkert resistApp” on page 16.</a>	
Further information on the materials can be found in chapter <a href="#">“3.2. Material specifications” on page 17.</a>	
<b>Non wetted parts</b>	
Sensor housing	<ul style="list-style-type: none"> <li>• For sensor with process connection size <math>\leq</math> DN 50/2": stainless steel 304/1.4301</li> <li>• For sensor with process connection size <math>&gt;</math> DN 50/2": stainless steel 316L/1.4435</li> </ul>
<b>Wetted parts</b>	
Measurement tube and process connection	Stainless steel 316L/1.4435 with low delta ferrite content
<b>Surface quality</b>	
Measurement tube (inner surface)	<ul style="list-style-type: none"> <li>• Ra <math>&lt;</math> 0.8 <math>\mu</math>m (30 <math>\mu</math>in.) or</li> <li>• Ra <math>&lt;</math> 0.4 <math>\mu</math>m (15 <math>\mu</math>in.) (electro-polished) according to ISO 4288</li> </ul>
Dimensions	Further information can be found in chapter <a href="#">“4. Dimensions” on page 20.</a>
Measuring element	Interdigital transducers
Measuring principle	Based on SAW (Surface Acoustic Waves)

DTS 1000270652 EN Version: Y Status: RL (released | freigegeben | validé) printed: 12.04.2024

**Measuring range**

Volume flow rate measurement	0...1.7 m³/h up to 0...200 m³/h Further information can be found in chapter <b>“10.6. Ordering chart FLOWave L flowmeter with or without industrial communication” on page 34</b> or <b>“10.7. Ordering chart FLOWave S flowmeter” on page 38.</b>
Density measurement <sup>1)</sup>	0.8...1.3 g/cm³ (inactive by default, selectable upon request)
Mass flow rate measurement <sup>1)</sup>	0...1 360 kg/h up to 0...260 000 kg/h (inactive by default, selectable upon request)
Temperature measurement	-20...+140 °C (-4...+284 °F)
Special function	Active by default, deselectable upon request. <ul style="list-style-type: none"> <li>• ATF: acoustic transmission factor</li> <li>• DF: differentiation factor</li> </ul> Further information can be found in chapter <b>“7.2. Special functions” on page 31.</b>

**Performance data**

**Volume flow rate measurement**

Under reference conditions i.e. measuring fluid = water free from gas bubbles and solids, ambient and water temperature = 23 °C ± 1 °C (73.4 °F ± 1.8 F), and short refresh time, while maintaining turbulent or laminar flow profile, with the minimum inlet (40 x DN) and outlet (1 x DN) distances and the appropriate internal diameter of the pipes. Deviation from reference conditions can be adjusted through the use of a built-in correction K factor adjustment or Teach-in Procedure.

Measurement deviation	<ul style="list-style-type: none"> <li>• From 10 % of full scale up to full scale: ±0.4 % of the measured value</li> <li>• From 1 % of full scale up to 10 % of full scale: ±0.08 % of full scale</li> </ul> Further information can be found in chapter <b>“5.2. Measurement deviation table” on page 26.</b>
Repeatability	<ul style="list-style-type: none"> <li>• From 10 % of full scale up to full scale: ±0.2 % of the measured value</li> <li>• From 1 % of full scale up to 10 % of full scale: ±0.04 % of full scale</li> </ul>
Refresh time	Selectable between very short, short and long Further information can be found in chapter <b>“5.3. Refresh time table” on page 27.</b>

**Density measurement**

As an option<sup>1)</sup>

Under reference conditions i.e. measuring fluid = water free from gas bubbles and solids, ambient and water temperature = 23 °C ± 1 °C (73.4 °F ± 1.8 F). Deviations from reference conditions, especially exposure of the device to temperatures above 90 °C can be adjusted through the use of a built in adjustment procedure (see **user manual Type 8098** ▶).

Measurement deviation	<ul style="list-style-type: none"> <li>• Standard product adjustment: ±2 % of the measured value</li> <li>• After Teach-In: ±1 % of the measured value (at teach-in density value)</li> </ul>
Repeatability	±1 % of the measured value
Refresh time	Selectable between very short, short and long Further information can be found in chapter <b>“5.3. Refresh time table” on page 27.</b>

**Mass flow rate measurement**

As an option<sup>1)</sup>

Under reference conditions i.e. measuring fluid = water free from gas bubbles and solids, ambient and water temperature = 23 °C ± 1 °C (73.4 °F ± 1.8 F), and short refresh time, while maintaining turbulent or laminar flow profile, with the minimum inlet (40 x DN) and outlet (1 x DN) distances and the appropriate internal diameter of the pipes. Deviation from reference conditions, can be adjusted through the use of a built-in correction K factor adjustment or Teach-in Procedure.

Measurement deviation	<ul style="list-style-type: none"> <li>• Standard K-factor:                             <ul style="list-style-type: none"> <li>– From 10 % of full scale up to full scale: ±2.4 % of the measured value</li> <li>– From 1 % of full scale up to 10 % of full scale: ±(2 % of the measured value + 0.08 % of full scale)</li> </ul> </li> <li>• After Teach-In:                             <ul style="list-style-type: none"> <li>– From 10 % of full scale up to full scale: ±1.4 % of the measured value at teach-in density and mass flow rate values</li> <li>– From 1 % of full scale up to 10 % of full scale: ±(1 % of the measured value + 0.08 % of full scale) at teach-in density and mass flow rate values</li> </ul> </li> </ul> Further information can be found in chapter <b>“5.2. Measurement deviation table” on page 26.</b>
Repeatability	<ul style="list-style-type: none"> <li>• From 10 % of full scale up to full scale: ±1.2 % of the measured value</li> <li>• From 1 % of full scale up to 10 % of full scale: ±(1 % of the measured value + 0.04 % of full scale)</li> </ul>
Refresh time	Selectable between very short, short and long Further information can be found in chapter <b>“5.3. Refresh time table” on page 27.</b>

**Temperature measurement**

Measurement deviation	<ul style="list-style-type: none"> <li>• For T° ≤ 100 °C (+212 °F): ±1 °C (+1.8 °F)</li> <li>• For 100 °C (+212 °F) &lt; T° &lt; 140 °C (+284 °F): ±1.5 %</li> </ul>
Refresh time	Approx. 0.1 s

DTS 1000270652 EN Version: Y Status: RL (released | freigegeben | validé) printed: 12.04.2024

**Original gravity measurement (degree Plato)** As an option <sup>1)</sup>

Under reference conditions with flowing barley beer wort free from gas bubbles and solids, measured at ambient temperature = 23 °C ± 1 °C. For other types of wort, a different behaviour of the device can be observed. In this case, adjust the device using the concentration menus. See the **supplement to operating instructions for concentration measurement Type 8098** ▶ for more information.

Performance / Measurement use case	Outlet section of the lauter tun	Outlet section of the kettle	Outlet section of wort chiller
Measuring range	0...25 °P	8...25 °P	5...25 °P
Fluid temperature	65...80 °C	70...100 °C	5...25 °C
Measurement deviation	± 0.5 °P	± 0.5 °P	± 0.5 °P
Repeatability	± 0.2 °P	± 0.2 °P	± 0.2 °P
Resolution	0.01 °P	0.01 °P	0.01 °P

As the medium used to measure the degrees Plato differs from water, volumetric flow performances may vary from previously mentioned (see **"Volume flow rate measurement"** on page 5). In this case, adjust the measurements to the process conditions, using the teach-in process.

**Electrical data**

Operating voltage	12...35 V DC ± 10 %, filtered and regulated Connection to main supply: permanent, through external SELV (Safety Extra Low Voltage) and LPS (Limited Power Source) power supply
Power source (not supplied)	Limited power source according to UL/EN 62368-1 standards or limited energy circuit according to UL/EN 61010-1 §9.4
DC reverse polarity protection	Yes

**Voltage supply cable**

- For cable gland
  - 0.2...1.5 mm<sup>2</sup> cross-section
  - In nickel plated brass:
    - Cable with maximum operating temperature greater than + 80 °C (+ 176 °F)
    - 5...14 mm diameter, shielded cable
  - In stainless steel:
    - Cable with maximum operating temperature greater than + 80 °C (+ 176 °F)
    - 6...12 mm diameter, shielded cable
- For 5-pin M12 male connector (A-coded)
  - Cable with maximum operating temperature greater than + 80 °C (+ 176 °F)
  - 3...6.5 mm diameter, shielded cable,
  - 0.75 mm<sup>2</sup> cross-section to connect to 5-pin M12 female connector (A-coded, not supplied)
- For 4-pin M12 female connector (D-coded)
  - Cable with maximum operating temperature greater than + 80 °C (+ 176 °F)
  - 5e / CAT-5 min. category, 100 m max. length, shielded conductor with minimum STP

**Medium data**

Fluid	The liquids should be non-dangerous, homogeneous, free of air or gas bubbles, free of suspended solids <sup>2)</sup> and must comply with article 4, §1 of 2014/68/EU directive. Further information can be found in chapter <b>"2.4. Pressure Equipment Directive (PED)"</b> on page 15. By default the FLOWave flowmeter is set for a fluid with a sound velocity <sup>3)</sup> <ul style="list-style-type: none"> <li>• between 1000 m/s and 2000 m/s for process connection DN 08, 3/8" and 1/2"</li> <li>• between 800 m/s and 2300 m/s for process connection DN ≥ 15 or ≥ 3/4"</li> </ul>
Fluid temperature	<ul style="list-style-type: none"> <li>• -20...+110 °C (-4...+230 °F). The maximum fluid temperature can be restricted by the ambient operating temperature.</li> <li>• Max. conditions for sterilisation process: up to +140 °C (+284 °F) (+130 °C (+266 °F) for ATEX/IECEX variant) for max. 60 min</li> <li>• Maximum temperature gradient: 10 °C/s (18 °F/s) (measured by the integrated sensor on the device)</li> </ul>

**Fluid pressure (max.)**

DN / Pipe standard	DIN 11850	ISO 1127	ASME BPE	SMS 3008
DN 08, 3/8", 1/2"	PN 25	PN 25	PN 25	–
DN 15, 3/4", DN 25, 1", 1 1/2"	PN 25	PN 25	PN 25	PN 25
DN 40	PN 25	PN 16	–	PN 25
DN 50, 2"	PN 16	PN 16	PN 16	PN 16
DN 65, 2 1/2", DN 80, 3"	PN 10	PN 10	PN 10	–

DTS 1000270652 EN Version: Y Status: RL (released | freigegeben | validé) printed: 12.04.2024

**Process/Pipe connection & communication**

**Process connection size / pipe size <sup>4)</sup> according to**

DIN 32676 series A / DIN 11850	Clamp: DN 08, DN 15, DN 25, DN 40, DN 50, DN 65 and DN 80
DIN 32676 series B / ISO 1127	Clamp: DN 08, DN 15, DN 25, DN 40, DN 50, DN 65 and DN 80
DIN 32676 series C / ASME BPE	Clamp: 3/8", 1/2", 3/4", 1", 1 1/2", 2", 2 1/2" and 3"
DIN 11864-2 form A series A / DIN 11850	Aseptic collar flange (BF) <sup>5)</sup> : DN 15, DN 25, DN 40, DN 50, DN 65 and DN 80
DIN 11864-2 form A series B / ISO 1127	Aseptic collar flange (BF) <sup>5)</sup> : DN 08, DN 15, DN 25, DN 40, DN 50, DN 65 and DN 80
DIN 11864-2 form A series C / ASME BPE	Aseptic collar flange (BF) <sup>5)</sup> : 1/2", 3/4", 1", 1 1/2" and 2"
DIN 11864-3 form A series A / DIN 11850	Aseptic collar clamp ferrule (BKS) <sup>5)</sup> : DN 15, DN 25, DN 40 and DN 50
DIN 11864-3 form A series B / ISO 1127	Aseptic collar clamp ferrule (BKS) <sup>5)</sup> : DN 08, DN 15, DN 25, DN 40 and DN 50
DIN 11864-3 form A series C / ASME BPE	Aseptic collar clamp ferrule (BKS) <sup>5)</sup> : 1/2", 3/4", 1", 1 1/2" and 2"
SMS 3017 / SMS 3008	Clamp: DN 25, DN 40 and DN 50
DIN 11851 series A / DIN 11850	Thread: DN 65 and DN 80
Device status	LED light ring according to NAMUR NE 107

**Approvals and conformities**

**Directives**

CE directive	Further information on the CE Directive can be found in chapter <b>"2.3. Standards"</b> on page 14.
Pressure equipment directive	<ul style="list-style-type: none"> <li>Complying with article 4, paragraph 1 of 2014/68/EU directive</li> <li>Further information on the pressure equipment directive can be found in chapter <b>"2.4. Pressure Equipment Directive (PED)"</b> on page 15.</li> <li>CRN 0C21751 declaration <sup>6)</sup></li> </ul>

Explosion protection	On request: ATEX/IECEX
North America (USA/Canada)	On request: UL Listed for the USA and Canada
Foods and beverages/Hygiene	<ul style="list-style-type: none"> <li>3-A (28-06) Sanitary Standards Inc.</li> <li>EHEDG (Type EL CLASS I) <sup>7)</sup></li> <li>FDA declaration of conformity</li> <li>On request:                             <ul style="list-style-type: none"> <li>USP class VI declaration</li> <li>ECR1935/2004 declaration</li> </ul> </li> </ul>

Materials	<ul style="list-style-type: none"> <li>Inspection certificate 3.1</li> <li>Certification of compliance ASME BPE</li> <li>On request:                             <ul style="list-style-type: none"> <li>Certification of conformity for the surface quality DIN 4762, EN ISO 4287, EN ISO 4288</li> <li>Certification of conformity for passivation and electro-polishing processes</li> </ul> </li> </ul>
-----------	--

Others	<ul style="list-style-type: none"> <li>Fluidic test report (test regarding volumetric flow rate or volume and mass flow rates, if density and mass flow rate option chosen)</li> <li>On request:                             <ul style="list-style-type: none"> <li>Calibration certificate (volumetric flow rate, volume and mass flow rates and density)</li> <li>Test report 2.2</li> <li>MTBF (Mean Time Between Failures) manufacturer declaration</li> </ul> </li> </ul>
--------	--

**Environment and installation**

Ambient temperature	<ul style="list-style-type: none"> <li>Operation: depends on the fluid temperature. Further information can be found in chapter <b>"5.1. Medium temperature diagram"</b> on page 25.</li> <li>Storage: -20...+70 °C (-4...+158 °F)</li> </ul>
Relative air humidity	≤ 85 %, without condensation
Height above sea level	Max. 2000 m
Operating condition	Continuous
Equipment mobility	Fixed device
Application range	Indoor and outdoor Protect the device against electromagnetic interference, ultraviolet rays and, when installed outdoors, against the effects of climatic conditions.

DTS 1000270652 EN Version: Y Status: RL (released | freigegeben | valide) printed: 12.04.2024

Degree of protection <sup>8.)</sup>	IP65, IP67 (according to IEC/EN 60529), NEMA 4X (according to NEMA250), if the product is wired and if the cable glands are tightened and the covers are screwed tight. Unused cable glands must be sealed with the stopper gaskets provided (mounted upon delivery of the product). An unused M12 fixed connector must be protected by the screwed plug.
Installation category	Category I according to UL/EN 61010-1
Pollution degree	Degree 2 according to UL/EN 61010-1

- 1.) Only for a flowmeter with a process connection size of DN 08...DN 80 or ½"...3"
- 2.) For fluids beyond this range, either check signal availability and stability under the target DN and process conditions, or contact your Bürkert sales office.
- 3.) Customer specific setting on request. Contact your Bürkert sales office.
- 4.) See dimension tables of the sensor in chapters "4.4. Flowmeter with clamp connection" on page 21, "4.5. Flowmeter with aseptic collar flange connection (BF)" on page 23, "4.6. Flowmeter with aseptic collar clamp connection (BKS)" on page 24, and "4.7. Flowmeter with thread connection" on page 25.
- 5.) In German: BF = Bundflansch, BKS= Bundklemmstutzen
- 6.) Only for a flowmeter with a process connection size of ¾"...2", pending for the other sizes.
- 7.) The EHEDG compliance for :
  - clamp connection according to DIN 32676 is only valid if used in combination with EHEDG-compliant gaskets from Combifit International B.V.
  - threaded connection according to DIN 11851 is only valid if used in combination with EHEDG-compliant gaskets from
    1. Kieselmann GmbH, Germany (ASEPTO-STAR k-flex upgrade gaskets) or
    2. Siersema Componenten Service (S.K.S.) B.V. (Netherlands SKS gasket set DIN 11851 EHEDG with EPDM or FKM inner gasket).
- 8.) Not evaluated by UL, only IP64 is evaluated by the ATEX notified body and by the IECEx certified body.

DTS 1000270652 EN Version: Y Status: RL (released | freigegeben | validé) printed: 12.04.2024





### 1.3. FLOWave L flowmeter

The FLOWave L flowmeter is available in four variants of the transmitter:

- Stainless steel transmitter with nickel plated brass cable glands and M12 male connector
- Stainless steel transmitter with stainless steel cable glands and M12 male connector (full stainless steel variant)
- Stainless steel transmitter with stainless steel M12 female and male connectors and industrial communication (Ethernet variant)
- Stainless steel transmitter with stainless steel cable glands and M12 male connector (ATEX/IECEx variant).



#### With or without industrial communication

The following data applies to all variants (unless otherwise stated).

Product properties																																	
<b>Material</b>																																	
Further information on the materials can be found in chapter <b>“3.2. Material specifications”</b> on page 17.																																	
<b>Non wetted parts</b>																																	
Blind cover	Stainless steel 304/1.4301																																
Transmitter housing	Stainless steel 304/1.4301																																
Functional earth element	Cylinder screw, washer, washer spring in stainless steel A4 and blind rivet nut in stainless steel 1.4578/A4																																
Pressure compensating element	Diaphragm in ePTFE (expanded polytetrafluoroethylene), O-ring in silicone 60 Shore A, body in stainless steel																																
Display module	Float glass, stainless steel 304/1.4301 and EPDM (ethylene propylene diene monomer) seal																																
Seal	VMQ silicone (Methyl Vinyl Silicone)																																
M12 fixed connector and screwed plug	<ul style="list-style-type: none"> <li>• 4-pin M12 female connector:                             <ul style="list-style-type: none"> <li>– Body in stainless steel 304L/1.4307, contact support in PBT GF30 (Polybutyleneterephthalate 30 % glass fibre reinforced) and seal in EPDM</li> </ul> </li> <li>• 5-pin M12 male connector:                             <ul style="list-style-type: none"> <li>– Body in nickel plated brass and seal in NBR (nitrile butadiene rubber) or</li> <li>– Body in stainless steel 316L/1.4404 and seal in NBR or VMQ silicone</li> </ul> </li> </ul>																																
Cable gland	<ul style="list-style-type: none"> <li>• Body in nickel plated brass and seal in TPE (thermoplastic elastomer) or</li> <li>• Body in stainless steel 304L/1.4307 and seal in TPE (FDA-compliant) or</li> <li>• Body in stainless steel 316L/1.4404 and seal in EPDM</li> </ul>																																
Blind plug	Black POM (polyoxymethylene), PA6 or PA																																
Display	<ul style="list-style-type: none"> <li>• 2.4", monochrome graphic (240 × 160 pixels)</li> <li>• Languages: German, English, French</li> </ul>																																
<b>Weight (approx. in kg)</b>	<table border="1"> <thead> <tr> <th></th> <th>DN 08, 3/8", 1/2"</th> <th>DN 15, 3/4"</th> <th>DN 25, 1"</th> <th>DN 40, 1 1/2"</th> <th>DN 50, 2"</th> <th>DN 65, 2 1/2"</th> <th>DN 80, 3"</th> </tr> </thead> <tbody> <tr> <td>Clamp</td> <td>2.1</td> <td>2</td> <td>2.2</td> <td>3</td> <td>3.2</td> <td>5.4</td> <td>5.5</td> </tr> <tr> <td>Flange</td> <td>2.3</td> <td>2.4</td> <td>2.7</td> <td>3.6</td> <td>3.8</td> <td>6</td> <td>6.2</td> </tr> <tr> <td>Thread (dairy thread)</td> <td>–</td> <td>–</td> <td>–</td> <td>–</td> <td>–</td> <td>5.7</td> <td>6.1</td> </tr> </tbody> </table>		DN 08, 3/8", 1/2"	DN 15, 3/4"	DN 25, 1"	DN 40, 1 1/2"	DN 50, 2"	DN 65, 2 1/2"	DN 80, 3"	Clamp	2.1	2	2.2	3	3.2	5.4	5.5	Flange	2.3	2.4	2.7	3.6	3.8	6	6.2	Thread (dairy thread)	–	–	–	–	–	5.7	6.1
	DN 08, 3/8", 1/2"	DN 15, 3/4"	DN 25, 1"	DN 40, 1 1/2"	DN 50, 2"	DN 65, 2 1/2"	DN 80, 3"																										
Clamp	2.1	2	2.2	3	3.2	5.4	5.5																										
Flange	2.3	2.4	2.7	3.6	3.8	6	6.2																										
Thread (dairy thread)	–	–	–	–	–	5.7	6.1																										
<b>Performance data</b>																																	
Frequency resolution	0.05 Hz over 0...2 000 Hz range																																
4...20 mA output uncertainty	±0.04 mA																																
4...20 mA output resolution	0.8 µA																																

DTS 1000270652 EN Version: Y Status: RL (released | freigegeben | validé) printed: 12.04.2024

### Electrical data

Power consumption	Without any consumption of output <ul style="list-style-type: none"> <li>For device with 2xM20x1.5 cable glands and 1x5-pin M12 male connector: max. 5 W</li> <li>For device with 2x4-pin M12 female connectors and 1x5-pin M12 male connector, Ethernet variant: max. 8 W</li> <li>For device with 2x4-pin M12 female connectors and 1x5-pin M12 male connector, Ethernet variant, with display module: max. 9 W</li> </ul>
-------------------	--

### Output

Number of outputs	3 (1 digital, 1 analogue and 1 configurable: digital or analogue)
Digital output	<b>Valid for non-Ethernet variants only</b> Overload information (through software diagnostics function) Transistor: <ul style="list-style-type: none"> <li>Type: NPN or PNP (wiring dependent), open collector, galvanically isolated</li> <li>Operating modes: pulse (by default), On/Off, threshold, frequency (user configurable)</li> <li>10 kHz, 5...35 V DC, max. 700 mA, max. pulse duration: 2 s, selectable limits:             <ul style="list-style-type: none"> <li>0.0001...10 000 pulses/litre or 0.0001...9 999.99 litres/pulse</li> <li>0.0001...10 000 pulses/kg or 0.0001...9 999.99 kg/pulse<sup>1)</sup></li> </ul> </li> <li>Protected against polarity reversals of DC and overloads</li> </ul>
Analogue output	Open loop detection (through software diagnostics function) Current: <ul style="list-style-type: none"> <li>4...20 mA</li> <li>3.6 mA or 22 mA to indicate an error (only if 4...20 mA scale selected); galvanically isolated</li> <li>Max. loop impedance: 1 300 Ω at 35 V DC, 1 000 Ω at 30 V DC, 700 Ω at 24 V DC, 450 Ω at 18 V DC</li> </ul>

### Process/Pipe connection & communication

Electrical connection	2xM20x1.5 cable glands and 1x5-pin M12 male connector (A-coded) for non-Ethernet variants only
Data transfer	External communication through büS (Bürkert system bus, CANopen protocol)

### Environment and installation

Ambient temperature	Operation: <ul style="list-style-type: none"> <li>For device with 2x M20x1.5 cable glands and 1x5-pin M12 male connector:             <ul style="list-style-type: none"> <li>-10...+70 °C (+14...+158 °F) or -10...+40 °C (+14...+104 °F) for ATEX/IECEX variant, if -20 °C (4 °F) ≤ fluid temperature ≤ 80 °C (176 °F),</li> <li>At a fluid temperature &gt;80 °C (176 °F), the maximum ambient temperature decreases linearly from 70 °C (158 °F) up to 40 °C (104 °F) or from 40 °C (104 °F) up to 30 °C (86 °F) for ATEX/IECEX variant. This means that at a fluid temperature of 80 °C (176 °F) the ambient temperature may be a maximum of 70 °C and at a fluid temperature of 140 °C (130 °C for the ATEX/IECEX variant) the ambient temperature may only be a maximum of 40 °C (30 °C for the ATEX/IECEX variant).</li> </ul> </li> <li>For device with 2x4-pin M12 female connectors and 1x5-pin M12 male connector, Ethernet variant: -10...+55 °C (+14...+131 °F)</li> </ul> Further information can be found in chapter <b>“5.1. Medium temperature diagram”</b> on page 25.
---------------------	--

1.) Only if option density and mass flow is activated.

**With industrial communication (Ethernet variant)**

<b>Process/Pipe connection &amp; communication</b>	
Electrical connection	2 × 4-pin M12 female connectors (D-coded) and 1 × 5-pin M12 male connector (A-coded)
<b>Industrial Communication</b>	
Supported network protocol	<ul style="list-style-type: none"> <li>• Modbus TCP</li> <li>• PROFINET</li> <li>• EtherNet/IP</li> <li>• EtherCAT</li> </ul>
Light-emitting diode	<ul style="list-style-type: none"> <li>• 2 Link/Act LEDs (green)</li> <li>• 2 Link LEDs (yellow)</li> </ul>
<b>Modbus TCP protocol</b>	
Protocol	Internet protocol, version 4 (IPv4)
Network topology	<ul style="list-style-type: none"> <li>• Tree</li> <li>• Star</li> <li>• Line (open daisy chain)</li> </ul>
IP configuration	<ul style="list-style-type: none"> <li>• Static IP address</li> <li>• Not supported: BOOTP (Bootstrap Protocol), DHCP (Dynamic Host Configuration)</li> </ul>
Transmission speed	10 or 100 MBit/s
<b>PROFINET protocol</b>	
PROFINET IO specification	V2.3
Network topology	<ul style="list-style-type: none"> <li>• Tree</li> <li>• Star</li> <li>• Ring (closed daisy chain)</li> <li>• Line (open daisy chain)</li> </ul>
Network management	<ul style="list-style-type: none"> <li>• LLDP (Link Layer Discovery Protocol)</li> <li>• SNMP V1 (Simple Network Management Protocol)</li> <li>• MIB (Management Information Base)</li> <li>• DCP (Discovery and Configuration Protocol)</li> </ul>
IP configuration	<ul style="list-style-type: none"> <li>• Manual (Device naming and IP setting)</li> </ul>
Transmission speed	100 MBit/s full duplex
Maximum supported conformance class	CC-B
Media Redundancy (for ring topology)	MRP client is supported
GSDml file	See <b>Device Description Files Type 8098</b> ▶ on the website under “Software”.
<b>EtherNet/IP protocol</b>	
Protocol	Internet protocol, version 4 (IPv4)
Network topology	<ul style="list-style-type: none"> <li>• Tree</li> <li>• Star</li> <li>• Ring (closed daisy chain)</li> <li>• Line (open daisy chain)</li> <li>• Linear (open Daisy Chain)</li> </ul>
IP configuration	<ul style="list-style-type: none"> <li>• Static IP address</li> <li>• BOOTP (Bootstrap Protocol)</li> <li>• DHCP (Dynamic Host Configuration Protocol)</li> </ul>
Transmission speed	10 or 100 MBit/s
Duplex mode	Half duplex, full duplex, auto-negotiation
MDI mode (Medium Dependant Interface)	Auto-MDIX
Predefined standard objects	Identity, Message Router, Assembly, Connection Manager, DLR, QoS, TCP/IP Interface, EtherNet Link object
EDS file	See <b>Device Description Files Type 8098</b> ▶ on the website under “Software”.

DTS 1000270652 EN Version: Y Status: RL (released | freigegeben | valide) printed: 12.04.2024

**EtherCAT protocol<sup>1.)</sup>**

Industrial Ethernet interface X1, X2	X1: EtherCAT IN, X2: EtherCAT OUT
Maximum number of cyclic input/output data	512 bytes in total
Maximum number of cyclic input data	1024 bytes
Maximum number of cyclic output data	1024 bytes
Acyclic communication (CoE)	<ul style="list-style-type: none"> <li>• SDO</li> <li>• SDO master-slave</li> <li>• SDO slave-slave (depends on master capacity)</li> </ul>
Type	Complex slave
Fieldbus Memory Management Unit (FMMU)	8
Sync Manager	4
Transmission speed	100 Mbit/s

**Approvals and conformities**

Others	<p>Network protocol:</p> <ul style="list-style-type: none"> <li>• PROFINET</li> <li>• EtherNet/IP</li> <li>• EtherCAT®</li> </ul>
--------	---

1.) EtherCAT® is a registered trademark and patented technology, licensed by Beckhoff Automation GmbH.

DTS 1000270652 EN Version: Y Status: RL (released | freigegeben | valide) printed: 12.04.2024

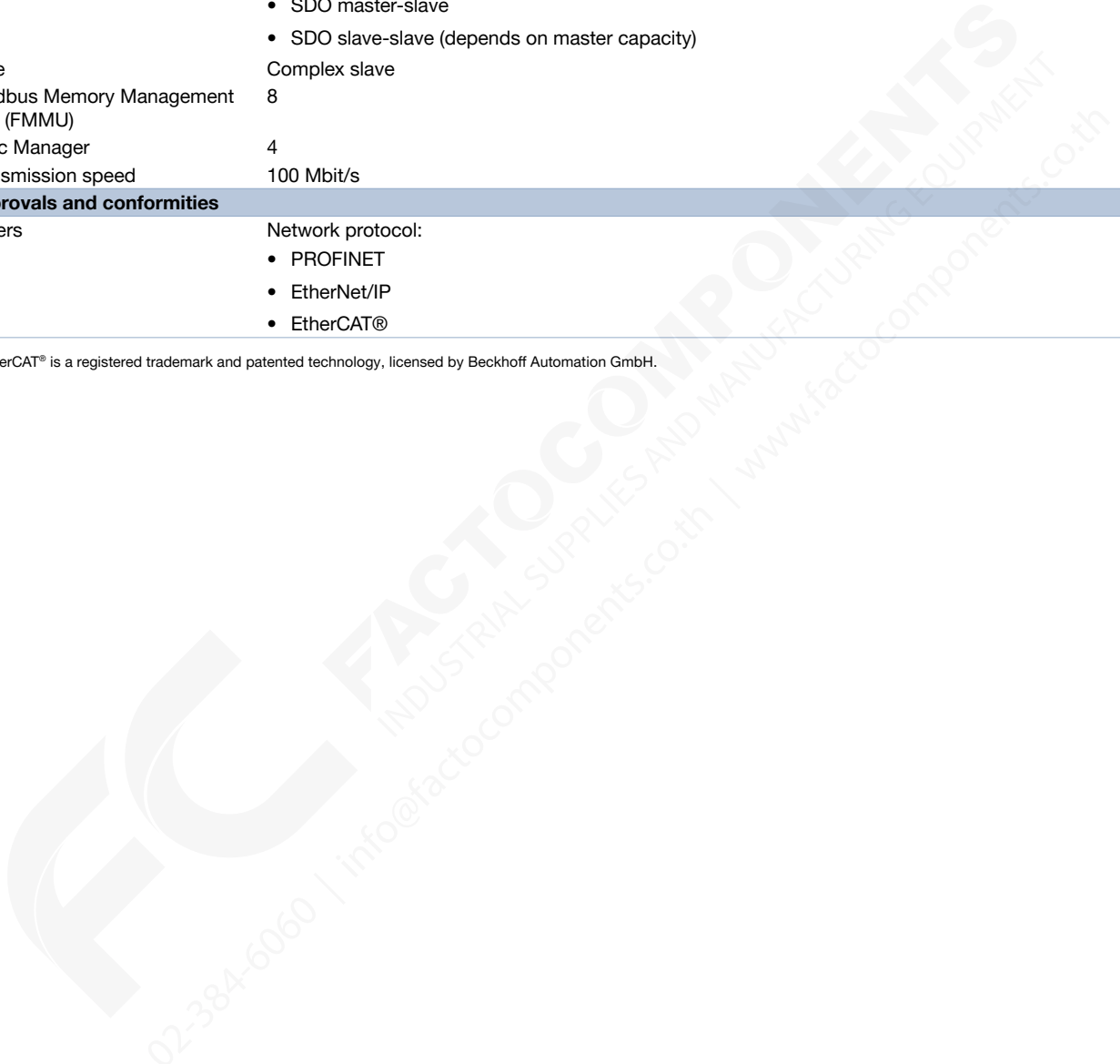

### 1.4. FLOWave S flowmeter

The FLOWave S flowmeter is available in four variants of the transmitter:

- Stainless steel transmitter without output and with stainless steel 5-pin M12 male connector
- Stainless steel transmitter with 2 configurable outputs (DO/AO) and stainless steel 8-pin M12 male connector
- Stainless steel transmitter without output and with stainless steel 5-pin M12 male connector (ATEX/IECEX variant)
- Stainless steel transmitter with 2 configurable outputs (DO/AO) and stainless steel 8-pin M12 male connector (ATEX/IECEX variant)



#### Product properties

##### Material

Further information on the materials can be found in chapter **“3.2. Material specifications”** on page 17.

##### Non wetted parts

Cover	Stainless steel 304/1.4301
Light guide	PC (Polycarbonate) and O-ring in EPDM (Ethylene Propylene Diene Monomer)
Transmitter housing	Stainless steel 304/1.4301
Functional earth element	Cylinder screw, washer, washer spring in stainless steel A4 and jumper of the ground terminal in stainless steel 304L
Seal	Between sensor and transmitter: VMQ silicone (Methyl Vinyl Silicone)
M12 fixed connector and screwed plug	5- or 8-pin M12 male connector: stainless steel 316L/1.4404 or 303/1.4305 and with seal in EPDM

Weight (approx. in kg)	DN 08, 3/8", 1/2"	DN 15, 3/4"	DN 25, 1"	DN 40, 1 1/2"	DN 50, 2"	DN 65, 2 1/2"	DN 80, 3"
Clamp	1.7	1.6	1.8	2.6	2.8	5.0	5.1
Flange	1.9	2.0	2.3	3.2	3.4	5.6	5.8
Thread (dairy thread)	–	–	–	–	–	5.3	5.7

#### Electrical data

- Power consumption
- For device without output: max. 2.5 W
  - For device with 2 outputs (DO/AO): max. 5 W

#### Output

- Number of outputs: 2, each configurable as digital or analogue output
- Digital output
- Overload information (through software diagnostics function)
- Transistor:
- Type: NPN or PNP (wiring dependent), open collector, galvanically isolated
  - Operating modes: pulse (by default), On/Off, threshold, frequency (user configurable)
  - 10 kHz, 5...35 V DC, max. 700 mA, max. pulse duration: 2 s, selectable limits:
    - 0.0001...10 000 pulses/litre or 0.0001...9 999.99 litres/pulse
    - 0.0001...10 000 pulses/kg or 0.0001...9 999.99 kg/pulse<sup>1)</sup>
  - Protected against polarity reversals of DC and overloads
- Analogue output
- Open loop detection (through software diagnostics function)
- Current:
- 4...20 mA
  - 3.6 mA or 22 mA to indicate an error (only if 4...20 mA scale selected); galvanically isolated
  - Max. loop impedance: 1300 Ω at 35 V DC, 1000 Ω at 30 V DC, 700 Ω at 24 V DC, 450 Ω at 18 V DC

#### Process/Pipe connection & communication

- Electrical connection
- 1 × 5-pin M12 male connector (A-coded) for device without output
  - 1 × 8-pin M12 male connector (A-coded) for device with 2 outputs

DTS 1000270652 EN Version: Y Status: RL (released | freigegeben | validé) printed: 12.04.2024

## Data transfer

- Device without output: external communication through büS (Bürkert system bus, CANopen protocol)
- Device with 2 outputs: büS connection only to the Bürkert Communicator for configuration and software update of the device. Due to the missing CAN shield the conventional büS/ CANopen communication is not recommended.

**Environment and installation**

## Ambient temperature

## Operation:

- All variants except ATEX/IECEX variant:
  - $-10...+70\text{ °C}$  ( $+14...+158\text{ °F}$ ) if  $-20\text{ °C}$  ( $4\text{ °F}$ )  $\leq$  fluid temperature  $\leq 80\text{ °C}$  ( $176\text{ °F}$ )
  - at a fluid temperature  $> 80\text{ °C}$  ( $176\text{ °F}$ ), the maximum ambient temperature decreases linearly from  $70\text{ °C}$  ( $158\text{ °F}$ ) up to  $40\text{ °C}$  ( $104\text{ °F}$ ).  
This means that at a fluid temperature of  $80\text{ °C}$  ( $176\text{ °F}$ ) the ambient temperature may be a maximum of  $70\text{ °C}$  ( $158\text{ °F}$ ) and at a fluid temperature of  $140\text{ °C}$  ( $284\text{ °F}$ ) the ambient temperature may only be a maximum of  $40\text{ °C}$  ( $104\text{ °F}$ ).
- ATEX/IECEX variant:
  - $-10...+60\text{ °C}$  ( $+14...+140\text{ °F}$ ) if  $-20\text{ °C}$  ( $4\text{ °F}$ )  $\leq$  fluid temperature  $\leq 100\text{ °C}$  ( $212\text{ °F}$ )
  - at a fluid temperature  $> 100\text{ °C}$  ( $212\text{ °F}$ ), the maximum ambient temperature decreases linearly from  $60\text{ °C}$  ( $140\text{ °F}$ ) up to  $45\text{ °C}$  ( $136\text{ °F}$ ).  
This means that at a fluid temperature of  $100\text{ °C}$  ( $212\text{ °F}$ ) the ambient temperature may be a maximum of  $60\text{ °C}$  ( $140\text{ °F}$ ) and at a fluid temperature of  $130\text{ °C}$  ( $266\text{ °F}$ ) the ambient temperature may only be a maximum of  $45\text{ °C}$  ( $136\text{ °F}$ ).

Further information can be found in chapter **“5.1. Medium temperature diagram”** on page 25.

1.) Only if option density measurement and mass flow rate measurement is activated

## 2. Approvals and conformities

### 2.1. General notes

- The approvals and conformities listed below must be stated when making enquiries. This is the only way to ensure that the product complies with all required specifications.
- Not all available variants of the device can be supplied with the below mentioned approvals or conformities.

### 2.2. Conformity

In accordance with the Declaration of Conformity, the product is compliant with the EU Directives.

### 2.3. Standards

The applied standards which are used to demonstrate compliance with the EU Directives are listed in the EU-Type Examination Certificate and/or the EU Declaration of Conformity.

### 2.4. Pressure Equipment Directive (PED)

The device conforms to article 4, paragraph 1 of the Pressure Equipment Directive (PED) 2014/68/EU under the following conditions:



#### Device used on a pipe

**Note:**

- The data in the table is independent of the chemical compatibility of the material and the fluid.
- PS = maximum admissible pressure (in bar), DN = nominal diameter of the pipe

Type of fluid	Conditions
Fluid group 1, article 4, paragraph 1.c.i	DN ≤ 25
Fluid group 2, article 4, paragraph 1.c.i	DN ≤ 32 or PS*DN ≤ 1000
Fluid group 1, article 4, paragraph 1.c.ii	DN ≤ 25 or PS*DN ≤ 2000
Fluid group 2, article 4, paragraph 1.c.ii	DN ≤ 200 or PS ≤ 10 or PS*DN ≤ 5000

### 2.5. Explosion protection

Approval	Description				
  	<p><b>Optional: Explosion protection</b> As a category 3 device suitable for zone 2/22 (optional).</p> <p>Ex marking of the components according to the following table:</p> <table border="1"> <thead> <tr> <th>FLOWave L flowmeter</th> <th>FLOWave S flowmeter</th> </tr> </thead> <tbody> <tr> <td> <b>ATEX</b> <ul style="list-style-type: none"> <li>• II 3G Ex ec IIC T4 Gc</li> <li>• II 3D Ex tc IIIC T110 °C Dc or T130 °C Dc</li> </ul> <b>IECEX</b> <ul style="list-style-type: none"> <li>• Ex ec IIC T4 Gc</li> <li>• Ex tc IIIC T110 °C Dc or T130 °C Dc</li> </ul> </td> <td> <b>ATEX</b> <ul style="list-style-type: none"> <li>• II 3G Ex ec IIC T4 Gc</li> <li>• II 3D Ex tc IIIC T130 °C Dc</li> </ul> <b>IECEX</b> <ul style="list-style-type: none"> <li>• Ex ec IIC T4 Gc</li> <li>• Ex tc IIIC T130 °C Dc</li> </ul> </td> </tr> </tbody> </table> <p>Measures to comply with ATEX/IECEX requirements: refer to the</p> <ul style="list-style-type: none"> <li>• <b>Supplement Type 8098 FLOWave L   ATEX/IECEX Variant</b> ▶ or</li> <li>• <b>Supplement Type 8098 FLOWave S   ATEX/IECEX Variant</b> ▶</li> </ul> <p>under user manual.</p> <p>The Ex. certification is only valid if the Bürkert device is used as described in the supplement ATEX/IECEX. If unauthorized changes are made to the device, the Ex. certification becomes invalid.</p>	FLOWave L flowmeter	FLOWave S flowmeter	<b>ATEX</b> <ul style="list-style-type: none"> <li>• II 3G Ex ec IIC T4 Gc</li> <li>• II 3D Ex tc IIIC T110 °C Dc or T130 °C Dc</li> </ul> <b>IECEX</b> <ul style="list-style-type: none"> <li>• Ex ec IIC T4 Gc</li> <li>• Ex tc IIIC T110 °C Dc or T130 °C Dc</li> </ul>	<b>ATEX</b> <ul style="list-style-type: none"> <li>• II 3G Ex ec IIC T4 Gc</li> <li>• II 3D Ex tc IIIC T130 °C Dc</li> </ul> <b>IECEX</b> <ul style="list-style-type: none"> <li>• Ex ec IIC T4 Gc</li> <li>• Ex tc IIIC T130 °C Dc</li> </ul>
FLOWave L flowmeter	FLOWave S flowmeter				
<b>ATEX</b> <ul style="list-style-type: none"> <li>• II 3G Ex ec IIC T4 Gc</li> <li>• II 3D Ex tc IIIC T110 °C Dc or T130 °C Dc</li> </ul> <b>IECEX</b> <ul style="list-style-type: none"> <li>• Ex ec IIC T4 Gc</li> <li>• Ex tc IIIC T110 °C Dc or T130 °C Dc</li> </ul>	<b>ATEX</b> <ul style="list-style-type: none"> <li>• II 3G Ex ec IIC T4 Gc</li> <li>• II 3D Ex tc IIIC T130 °C Dc</li> </ul> <b>IECEX</b> <ul style="list-style-type: none"> <li>• Ex ec IIC T4 Gc</li> <li>• Ex tc IIIC T130 °C Dc</li> </ul>				

### 2.6. North America (USA/Canada)

Approval	Description
	<p><b>Optional: UL Listed for the USA and Canada</b> The products are UL Listed for the USA and Canada according to:</p> <ul style="list-style-type: none"> <li>• UL 61010-1 (ELECTRICAL EQUIPMENT FOR MEASUREMENT, CONTROL, AND LABORATORY USE – Part 1: General Requirements)</li> <li>• CAN/CSA-C22.2 No. 61010-1</li> </ul> <p>Certificate number: 2017-10-27-E237737</p>

DTS 1000270652 EN Version: Y Status: RL (released | freigegeben | validé) printed: 12.04.2024

## 2.7. Foods and beverages/Hygiene

Approval	Description
	<b>3-A Sanitary Standards Inc. (valid for the variable code PE05)</b> The products comply with 3-A Sanitary Standards Inc (3-A SSI) as per certificate. Certificate authorization number: 1178
	<b>EHEDG (European Hygienic Engineering and Design Group) (Type EL CLASS I) (valid for the variable code PI01)</b> The EHEDG compliance is only valid <ul style="list-style-type: none"> <li>if the flowmeter with clamp connection according to DIN 32676 is used in combination with gaskets from Combifit International B.V.</li> <li>if the flowmeter with threaded connection according to DIN 11851 is used in combination with gaskets from                             <ul style="list-style-type: none"> <li>Kieselmann GmbH, Germany (ASEPTO-STAR k-flex upgrade gaskets) or</li> <li>Siersema Componenten Service (S.K.S.) B.V. (Netherlands SKS gasket set DIN 11851 EHEDG with EPDM or FKM inner gasket)</li> </ul> </li> </ul>

Conformity	Description
<b>FDA</b>	<b>FDA – Code of Federal Regulations (valid for the variable code PL02, PL03)</b> The devices are compliant in their composition with the Code of Federal Regulations published by the FDA (Food and Drug Administration, USA) according to the manufacturer's declaration.
<b>USP</b>	<b>United States Pharmacopeial Convention (USP) (valid for the variable code PL04)</b> All wetted materials are biocompatible according to the manufacturer's declaration.
	<b>EC Regulation 1935/2004 of the European Parliament and of the Council (valid for the variable code PL01, PL02)</b> All wetted materials are compliant with EC Regulation 1935/2004 according to the manufacturer's declaration.

## 2.8. Others

### Network protocol

Approval	Description
	<b>PROFINET</b> Certificate number: Z12446
	<b>EtherNet/IP</b> Document number: 11839
	EtherCAT® is a registered trademark and patented technology, licensed by Beckhoff Automation GmbH.

## 3. Materials

### 3.1. Bürkert resistApp

**Bürkert resistApp – Chemical resistance chart**

You want to ensure the reliability and durability of the materials in your individual application case? Verify your combination of media and materials on our website or in our resistApp.

Start chemical resistance check



### 3.2. Material specifications

#### FLOWave L flowmeter without industrial communication

**Note:**

The following picture describes a device with 2 x M20 x 1.5 cable glands, 1 x 5-pin M12 connector and clamp connection.

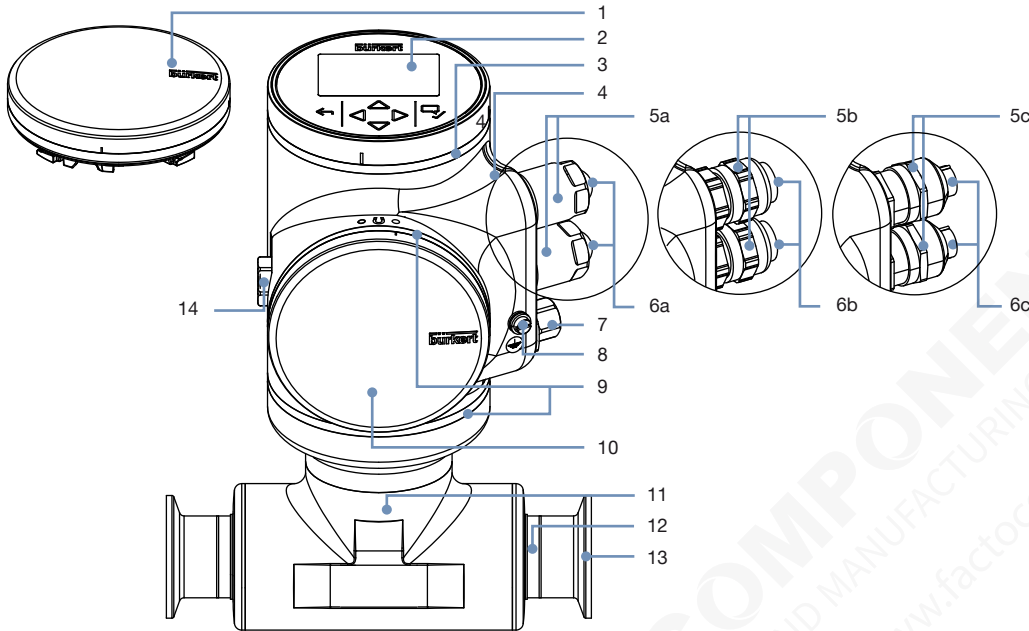

No.	Element	Material
1	Blind cover	Stainless steel 304/1.4301
2	Display module	Float glass, stainless steel 304/1.4301
3	Multi-colour LED behind seal (used for e.g. to indicate the status of the product, based on the NAMUR NE 107 standard)	VMQ silicone
4	Transmitter housing	Stainless steel 304/1.4301
5a	Cable gland (full stainless steel variant)	Body in stainless steel 304L/1.4307 and seal in TPE (according to FDA)
5b	Cable glands	Body in nickel plated brass and seal in TPE
5c	Cable glands (ATEX/IECEx variant)	Body in stainless steel 316L/1.4404 and seal in EPDM
6a	Blind plug (full stainless steel variant)	PA6
6b	Blind plug	Black POM
6c	Blind plug (ATEX/IECEx variant)	PA
7	5-pin M12 male connector (wired to bus) with screwed plug	<ul style="list-style-type: none"> <li>Body in stainless steel 316L/1.4404 and seal in NBR (if equipped with 5a) or in VMQ silicone (if equipped with 5c) or</li> <li>Body in nickel plated brass and seal in NBR (if equipped with 5b)</li> </ul>
8	Functional earth	Cylinder screw, washer, washer spring in stainless steel A4 and blind rivet nut in stainless steel 1.4578/A4
9	Seal	VMQ silicone
10	Blind cover	Stainless steel 304/1.4301
11	Sensor housing	For sensor with process connection: <ul style="list-style-type: none"> <li>≤ DN 50/2": stainless steel 304/1.4301</li> <li>&gt; DN 50/2": stainless steel 316L/1.4435</li> </ul>
12	Sensor measurement tube	Stainless steel 316L/1.4435 with low delta ferrite content
13	Process connection (either clamp connections or flange connections)	Stainless steel 316L/1.4435 with low delta ferrite content
14	Pressure compensating element	Diaphragm in ePTFE, O-ring in silicone 60 Shore A and body in stainless steel (316L/1.4404)

DTS 1000270652 EN Version: Y Status: RL (released | freigegeben | valide) printed: 12.04.2024

**FLOWave L flowmeter with industrial communication**

**Note:**

The following picture describes a device (Ethernet variant) with 2 × 4-pin M12 female connectors, 1 × 5-pin M12 male connector and flange connection.

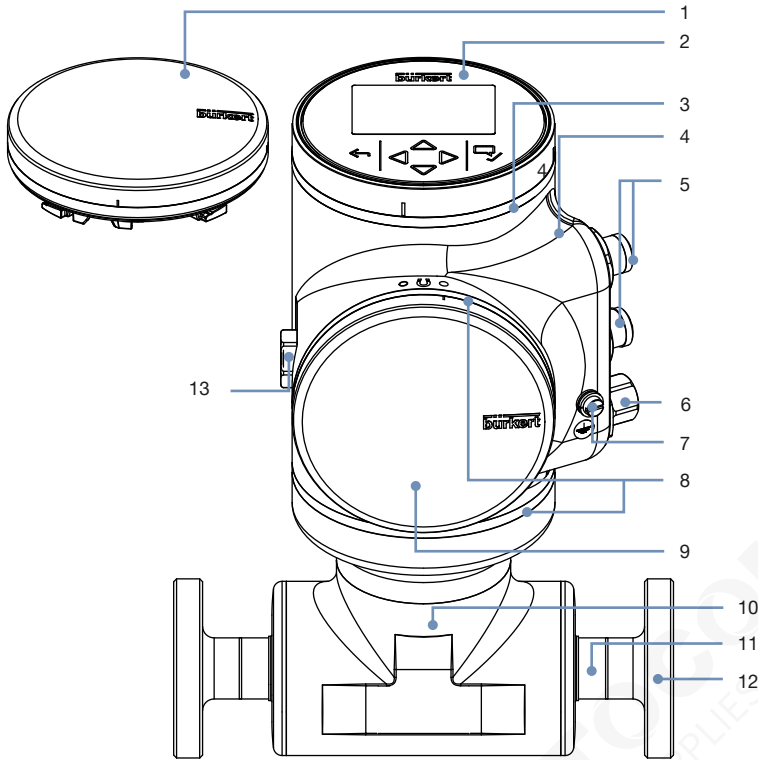

No.	Element	Material
1	Blind cover or	Stainless steel 304/1.4301
2	Display module	Float glass, stainless steel 304/1.4301
3	Multi-colour LED behind seal (used for e.g. to indicate the status of the product, based on the NAMUR NE 107 standard)	VMQ silicone
4	Transmitter housing	Stainless steel 304/1.4301
5	4-pin M12 female connectors with screwed plug	Body in stainless steel 304L/1.4307, contact support in PBT GF30 and seal in EPDM
6	5-pin M12 male connector (wired to bus) with screwed plug	Body in stainless steel 316L/1.4404 and seal in NBR
7	Functional earth	Cylinder screw, washer, washer spring: stainless steel A4 blind rivet nut: stainless steel 1.4578/A4
8	Blind cover	VMQ silicone
9	Seal	Stainless steel 304/1.4301
10	Sensor housing	Stainless steel 304/1.4301 <sup>1.)</sup>
11	Sensor measurement tube	Stainless steel 316L/1.4435 with low delta ferrite content
12	Process connection (either clamp connections or flange connections)	Stainless steel 316L/1.4435 with low delta ferrite content
13	Pressure compensating element	Diaphragm: ePTFE; support: polyester; O-ring: silicone 60 Shore A; body: stainless steel (316L/1.4404)

1.) If clamp connections according to DIN 32676 or threaded connections according to DIN 11851 are used instead of flange connections, the material of the sensor housing for DN > 50 is stainless steel 316L/1.4435

DTS 1000270652 EN Version: Y Status: RL (released | freigegeben | validé) printed: 12.04.2024

**FLOWave S flowmeter**

**Note:**

The following picture shows a device with 1 × 5-pin M12 male connector and clamp connection.

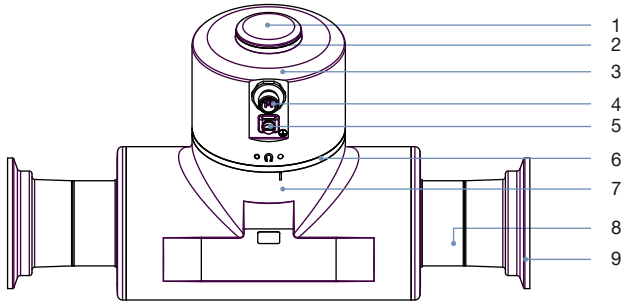

No.	Element	Material
1	Cover	Stainless steel 304/1.4301
2	Light guide for status display behind seal (used for e.g. indicating the status of the product, based on the NAMUR NE 107 standard)	PC and O-ring in EPDM
3	Transmitter housing	Stainless steel 304/1.4301
4	5-pin M12 male connector (wired to būs) with screwed plug or 8-pin M12 male connector (wired to būs as service interface <sup>1.)</sup> and 2 x DO/AO) (with screwed plug)	Stainless steel 316L/1.4404 or 303/1.4305 and seal in EPDM
5	Functional earth	<ul style="list-style-type: none"> <li>• Cylinder screw, washer, washer spring: stainless steel A4</li> <li>• Jumper of the ground terminal: stainless steel 304L</li> </ul>
6	Seal	VMQ silicone
7	Sensor housing	For sensor with process connection: <ul style="list-style-type: none"> <li>• ≤ DN 50/2": stainless steel 304/1.4301</li> <li>• &gt; DN 50/2": stainless steel 316L/1.4435</li> </ul>
8	Sensor measurement tube	Stainless steel 316L/1.4435 with low delta ferrite content
9	Process connection (either clamp connections or flange connections)	Stainless steel 316L/1.4435 with low delta ferrite content

1.) būs connection to the Bürkert communicator only for configuration and software update of the device. Due to the lack of CAN shielding, the conventional būs/CANopen communication is not recommended.

DTS 1000270652 EN Version: Y Status: RL (released | freigegeben | validé) printed: 12.04.2024

## 4. Dimensions

### 4.1. Transmitter of the FLOWave L flowmeter without industrial communication

**Note:**

Dimensions in mm, unless otherwise stated

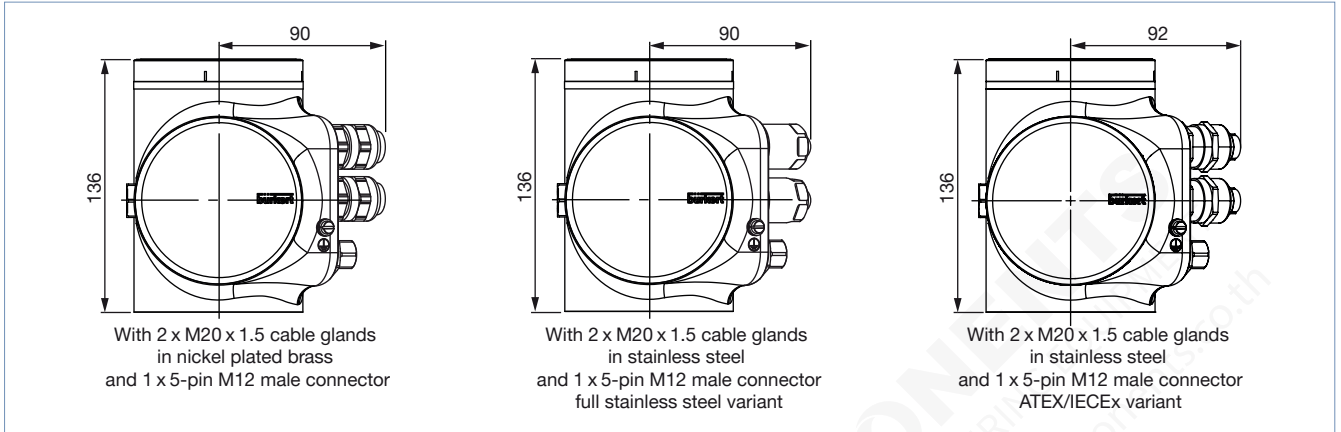

### 4.2. Transmitter of the FLOWave L flowmeter with industrial communication (Ethernet variant)

**Note:**

Dimensions in mm, unless otherwise stated

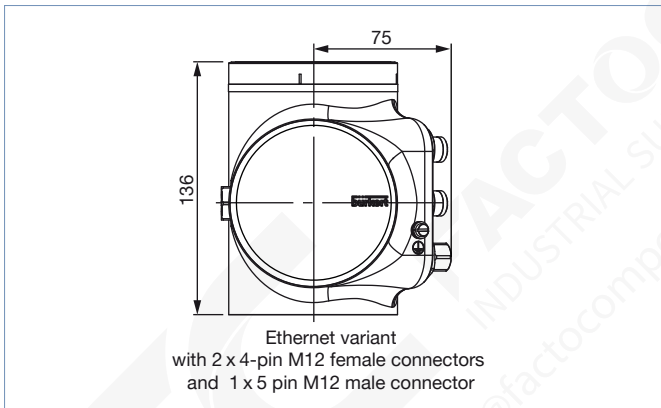

### 4.3. Transmitter of the FLOWave S flowmeter

**Note:**

Dimensions in mm, unless otherwise stated

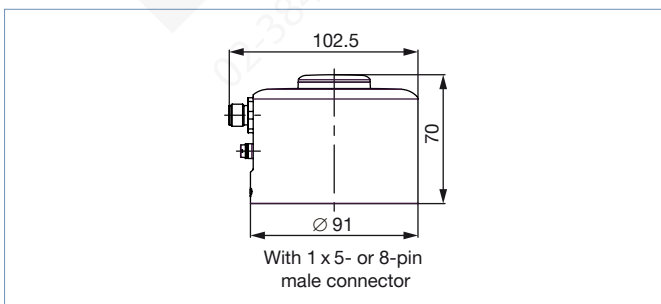

DTS 1000270652 EN Version: Y Status: RL (released | freigegeben | validé) printed: 12.04.2024

#### 4.4. Flowmeter with clamp connection

**Note:**

- Dimensions in mm, unless otherwise stated
- Clamp connection according to DIN 32676 series A, B or C, or SMS 3017

Sensor with process connection size  $\leq$  DN 50/2"

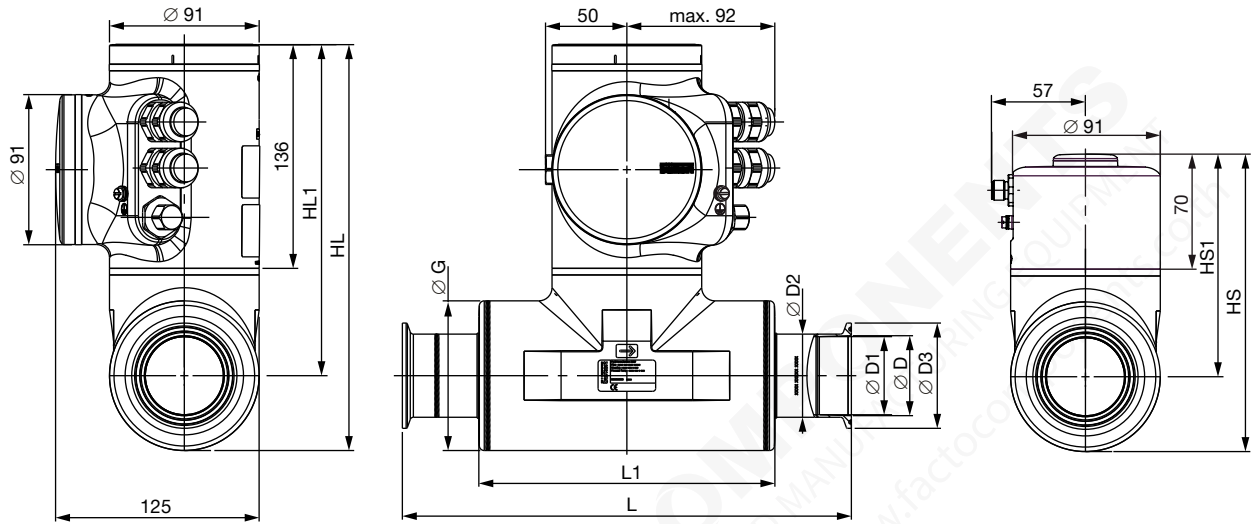

Sensor with process connection size  $>$  DN 50/2"

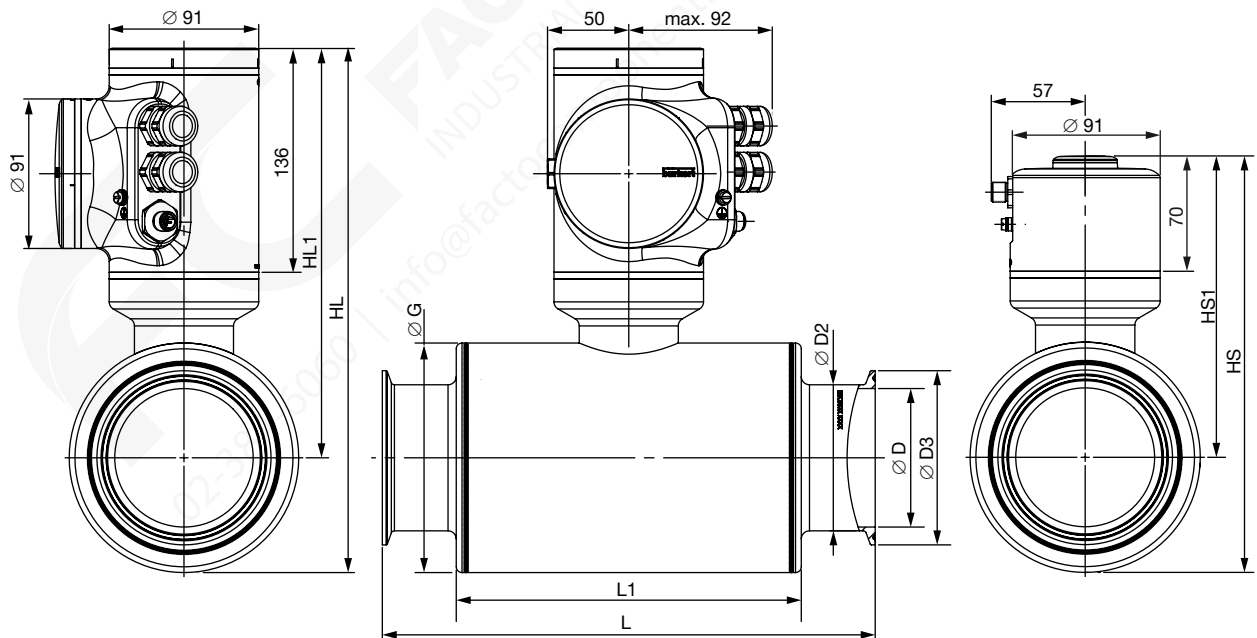

Process connection and pipe size		HL	HS	HL1	HS1	L	L1	ØD	ØD1	ØD2	ØD3	ØG
[mm]	[inch]											
<b>Clamp according to DIN 32676 series A and process pipe according to DIN 11866 series A (DIN 11850)</b>												
08	–	250	184	220	154	158	105	10	10	14	34	60.3
15 <sup>1.)</sup>	–	250	184	220	154	166	105	16	15.75	19.05	34	60.3
25 <sup>1.)</sup>	–	250	184	220	154	236	105	26	22.1	25.4	50.5	60.3
40 <sup>1.)</sup>	–	250	184	200	134	326	180	38	34.8	38.1	50.5	91
50 <sup>1.)</sup>	–	250	184	200	134	306	180	50	47.5	50.8	64	91
65	–	321	255	251	185	300	210	66	66	70	91	139.7
80	–	321	255	251	185	300	210	81	81	85	106	139.7
<b>Clamp according to DIN 32676 series B and process pipe according to DIN 11866 series B (ISO 1127)</b>												
08	–	250	184	220	154	158	105	10.3	10.3	14	25	60.3
15	–	250	184	220	154	168	105	18.1	18.1	21.3	50.5	60.3
15 <sup>2.)</sup>	–	250	184	220	154	168	105	18.1	18.1	21.3	34	60.3
25	–	250	184	220	154	175	120	29.7	29.7	33.7	50.5	60.3
40	–	250	184	200	134	273	180	44.3	44.3	48.3	64	91
50	–	250	184	200	134	273	180	56.3	56.3	60.3	77.5	91
65	–	321	255	251	185	300	210	72.1	72.1	76.1	91	139.7
80	–	321	255	251	185	300	210	84.3	84.3	88.9	106	139.7
<b>Clamp according to DIN 32676 series C and process pipe according to DIN 11866 series C (ASME BPE)</b>												
–	3/8	250	184	220	154	158	105	7.75	7.75	14	25	60.3
–	1/2	250	184	220	154	158	105	9.4	9.4	14	25	60.3
–	3/4	250	184	220	154	143	105	15.75	15.75	19.05	25	60.3
–	1	250	184	220	154	143	105	22.1	22.1	25.4	50.5	60.3
–	1 1/2	250	184	200	134	273	180	34.8	34.8	38.1	50.5	91
–	2	250	184	200	134	273	180	47.5	47.5	50.8	64	91
–	2 1/2	321	255	251	185	300	210	60.2	60.2	63.5	77.5	139.7
–	3	321	255	251	185	300	210	72.9	72.9	76.2	91	139.7
<b>Clamp according to SMS 3017 and process pipe according to SMS 3008</b>												
25 <sup>1.)</sup>	–	250	184	220	154	143	105	22.6	22.1	25.4	50.5	60.3
40 <sup>1.)</sup>	–	250	184	200	134	273	180	35.6	34.8	38.1	50.5	91
50 <sup>1.)</sup>	–	250	184	200	134	273	180	48.6	47.5	50.8	64	91

1.) DIN 32676 series A and SMS 3017 based on ASME BPE measurement tube sizes with adapted concentric clamp connection, design according to EHEDG DOC8 guidelines  
 2.) Similar to DIN 32676 series B, but with clamp connection 34.0

DTS 1000270652 EN Version: Y Status: RL (released | freigegeben | validé) printed: 12.04.2024

### 4.5. Flowmeter with aseptic collar flange connection (BF)

**Note:**

- Dimensions in mm, unless otherwise stated
- Aseptic collar flange connection (BF) according to DIN 11864-2 form A series A, B or C

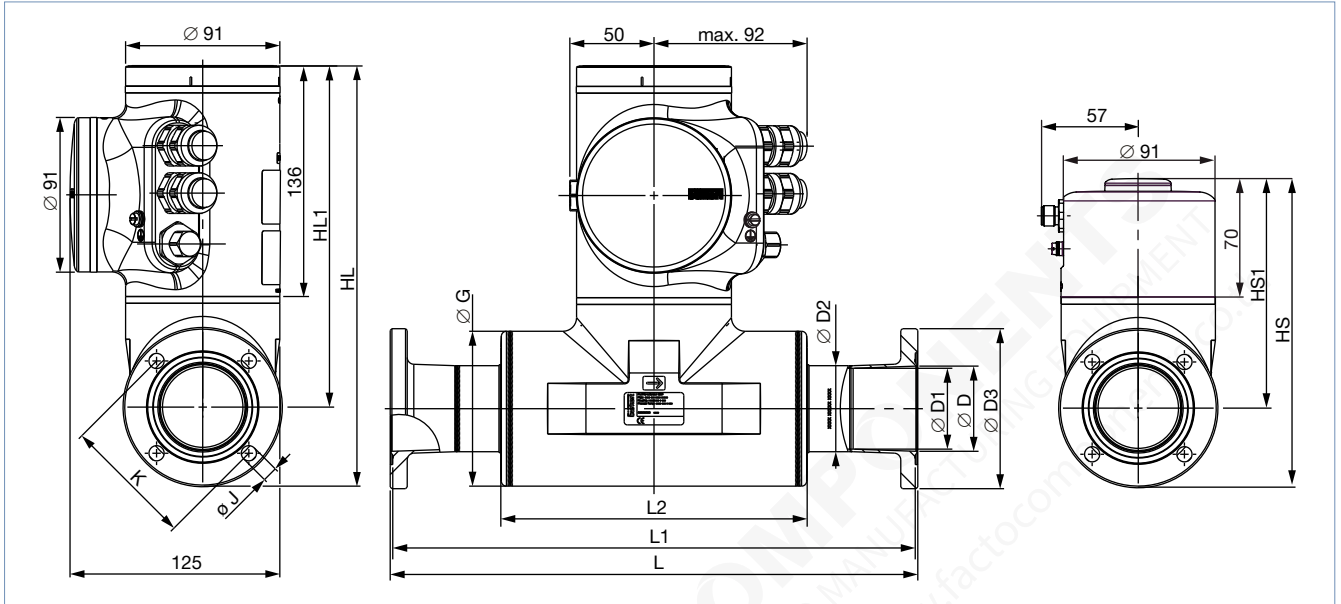

Process connection and pipe size		HL	HS	HL1	HS1	L	L1	L2	Ø D	Ø D1	Ø D2	Ø D3	Ø G	Ø J	K
[mm]	[inch]														
<b>Flange according to DIN 11864-2 series A and process pipe according to DIN 11866 series A (DIN 11850)</b>															
15 <sup>1.)</sup>	-	250	184	220	154	166	163	105	16	15.75	19.05	59	60.3	9	42
25 <sup>1.)</sup>	-	250	184	220	154	240	237	105	26	22.1	25.4	70	60.3	9	53
40 <sup>1.)</sup>	-	250	184	200	134	330	327	180	38	34.8	38.1	82	91	9	65
50 <sup>1.)</sup>	-	250	184	200	134	310	307	180	50	47.5	50.8	94	91	9	77
65	-	321	255	251	185	300	297	210	66	66	70	113	139.7	9	95
80	-	350	283	265	199	300	297	210	81	81	85	133	168.3	11	112
<b>Flange according to DIN 11864-2 series B and process pipe according to DIN 11866 series B (ISO 1127)</b>															
08	-	250	184	220	154	158	155	105	10.3	10.3	14	54	60.3	9	37
15	-	250	184	220	154	173	170	105	18.1	18.1	21.3	62	60.3	9	45
25	-	250	184	220	154	190	187	120	29.7	29.7	33.7	74	60.3	9	57
40	-	250	184	200	134	278	275	180	44.3	44.3	48.3	88	91	9	71
50	-	250	184	200	134	265	262	180	56.3	56.3	60.3	103	91	9	85
65	-	350	283	265	199	300	297	210	72.1	72.1	76.1	125	168.3	11	104
80	-	350	283	265	199	300	297	210	84.3	84.3	88.9	137	168.3	11	116
<b>Flange according to DIN 11864-2 series C and process pipe according to DIN 11866 series C (ASME BPE)</b>															
-	½	250	184	220	154	158	155	105	9.4	9.4	14	54	60.3	9	37
-	¾	250	184	220	154	171	168	105	15.75	15.75	19.05	59	60.3	9	42
-	1	250	184	220	154	168	165	105	22.1	22.1	25.4	66	60.3	9	49
-	1½	250	184	200	134	278	275	180	34.8	34.8	38.1	79	91	9	62
-	2	250	184	200	134	278	275	180	47.5	47.5	50.8	92	91	9	75

1.) DIN 11864-2 series A based on ASME BPE measurement tube sizes with adapted concentric flange connection, design according to EHEDG DOC8 guidelines

DTS 1000270652 EN Version: Y Status: RL (released | freigegeben | valide) printed: 12.04.2024

#### 4.6. Flowmeter with aseptic collar clamp connection (BKS)

**Note:**

- Dimensions in mm, unless otherwise stated
- Aseptic collar clamp connection (BKS) according to DIN 11864-3 form A series A, B or C

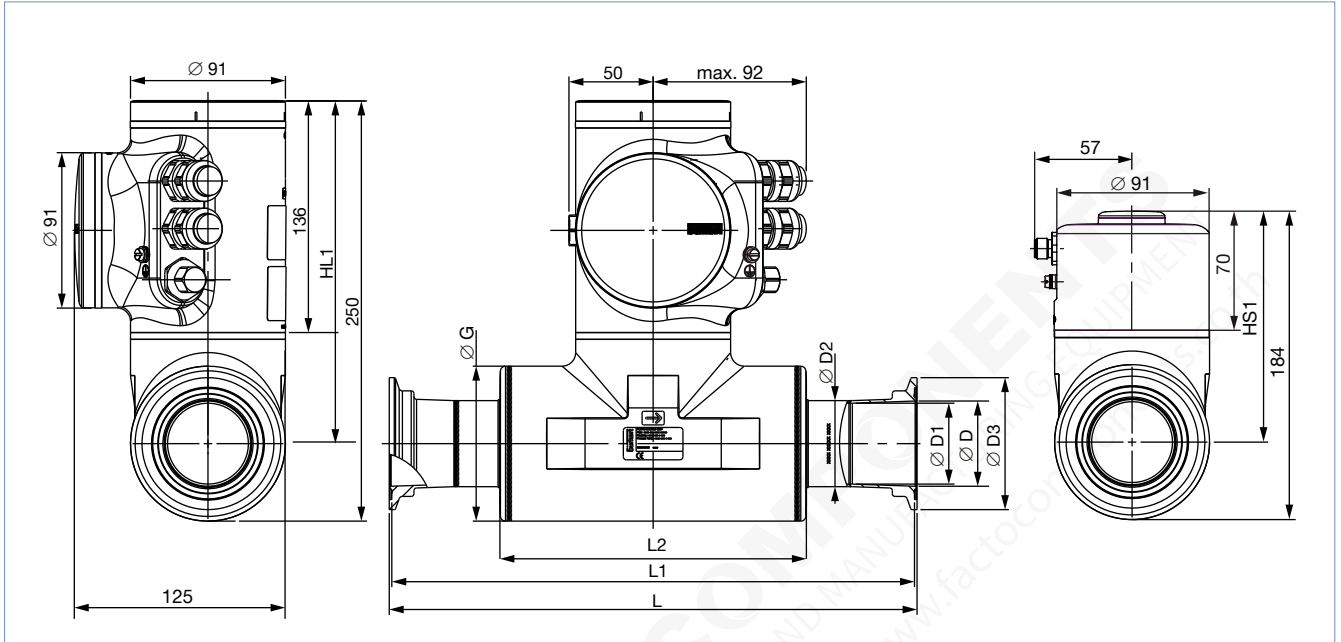

Process connection and pipe size		HL1	HS1	L	L1	L2	Ø D	Ø D1	Ø D2	Ø D3	Ø G
[mm]	[inch]										
<b>Clamp according to DIN 11864-3 series A and process pipe according to DIN 11866 series A (DIN 11850)</b>											
15 <sup>1.)</sup>	-	220	154	166	163	105	16	15.75	19.05	34	60.3
25 <sup>1.)</sup>	-	220	154	240	237	105	26	22.1	25.4	50.5	60.3
40 <sup>1.)</sup>	-	200	134	330	327	180	38	34.8	38.1	64	91
50 <sup>1.)</sup>	-	200	134	310	307	180	50	47.5	50.8	77.5	91
<b>Clamp according to DIN 11864-3 series B and process pipe according to DIN 11866 series B (ISO 1127)</b>											
08	-	220	154	158	155	105	10.3	10.3	14	34	60.3
15	-	220	154	169	166	105	18.1	18.1	21.3	34	60.3
25	-	220	154	190	187	120	29.7	29.7	33.7	50.5	60.3
40	-	200	134	280	277	180	44.3	44.3	48.3	64	91
50	-	200	134	271	268	180	56.3	56.3	60.3	91	91
<b>Clamp according to DIN 11864-3 series C and process pipe according to DIN 11866 series C (ASME BPE)</b>											
-	½	220	154	158	155	105	9.4	9.4	14	34	60.3
-	¾	220	154	167	164	105	15.75	15.75	19.05	34	60.3
-	1	220	154	164	161	105	22.1	22.1	25.4	50.5	60.3
-	1½	200	134	278	275	180	34.8	34.8	38.1	64	91
-	2	200	134	279	276	180	47.5	47.5	50.8	77.5	91

1.) DIN 11864-3 series A based on ASME BPE measurement tube sizes with adapted concentric clamp connection, design according to EHEDG DOC8 guidelines

DTS 1000270652 EN Version: Y Status: RL (released | freigegeben | valide) printed: 12.04.2024



### 4.7. Flowmeter with thread connection

**Note:**

- Dimensions in mm, unless otherwise stated
- Thread connection according to DIN 11851 series A

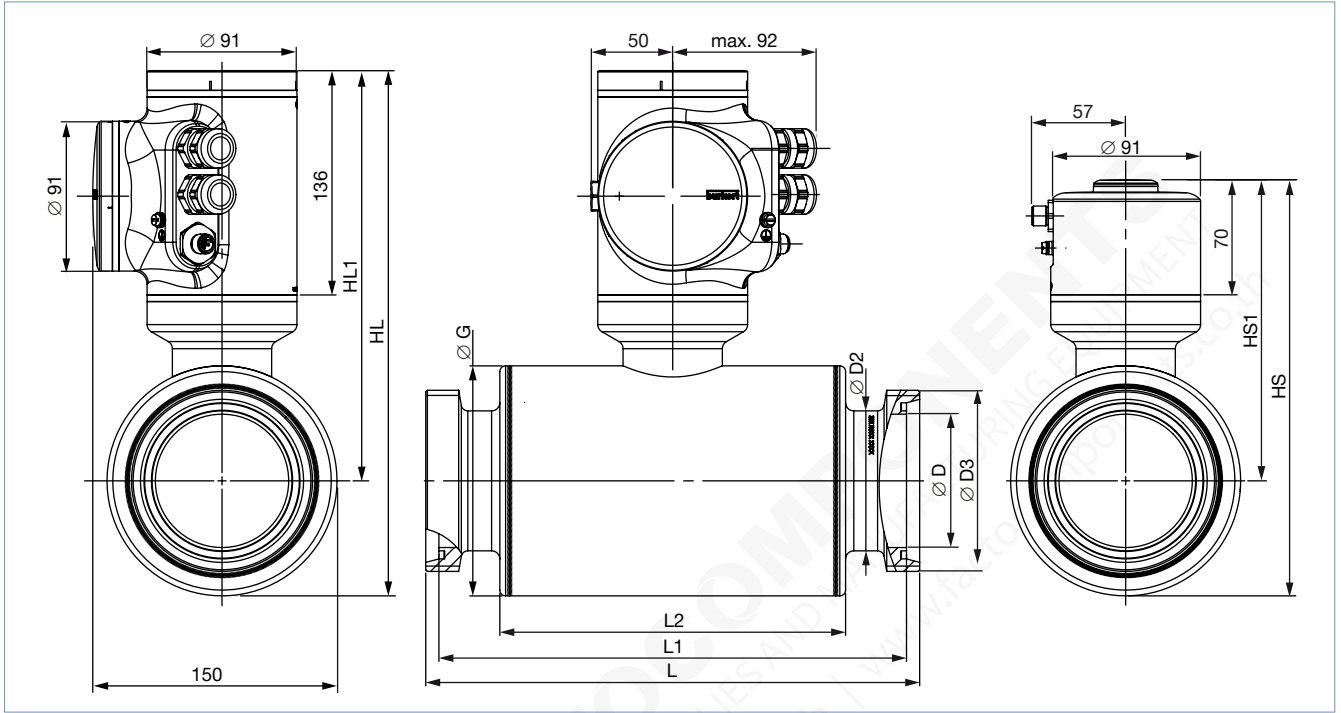

Process connection and pipe size [mm]	HL	HS	HL1	HS1	L	L1	L2	Ø D	Ø D2	Ø D3 <sup>1.)</sup>	Ø G
<b>Thread according to DIN 11851</b>											
65	321	255	251	185	300	284	210	66	70	Rd 95 x 1/6	139.7
80	321	255	251	185	300	284	210	81	85	Rd 110 x 1/4	139.7

1.) Thread according to DIN 405-1

## 5. Performance specifications

### 5.1. Medium temperature diagram

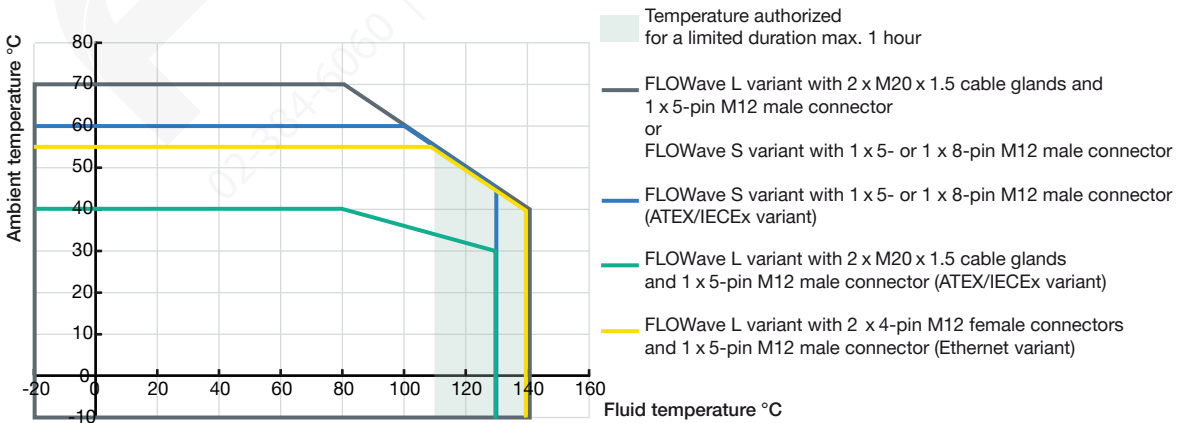

DTS 1000270652 EN Version: Y Status: RL (released | freigegeben | validé) printed: 12.04.2024

5.2. Measurement deviation table

Note:

- This table shows the measurement according to pipe diameter and process connection standards, per measuring range.
- In the following table, the term "full scale" refers to full scale of volume flow rate, i.e. the flow rate corresponding to 10 m/s flow velocity.

DN	Pipe standard	Flow velocity in sensor tube in [m/s] in % of full scale	0.1	1	10
			1	10	100
¾"	ASME BPE	Volume flow rate range (m³/h)	0.017	0.17	1.7
			± 0.08 % of full scale	± 0.4 % of measured value	
½"	ASME BPE	Volume flow rate range (m³/h)	0.025	0.25	2.5
			± 0.08 % of full scale	± 0.4 % of measured value	
08	DIN 11850	Volume flow rate range (m³/h)	0.028	0.28	2.8
	ISO 1127	Volume flow rate range (m³/h)	0.03	0.3	3.0
¾"	ASME BPE	Volume flow rate range (m³/h)	0.07	0.7	7.0
			± 0.08 % of full scale	± 0.4 % of measured value	
15	DIN 11850	Volume flow rate range (m³/h)	0.073	0.73	7.3
	ISO 1127	Volume flow rate range (m³/h)	0.10	1.0	10
1"	ASME BPE	Volume flow rate range (m³/h)	0.14	1.4	14
			± 0.08 % of full scale	± 0.4 % of measured value	
25	SMS 3008	Volume flow rate range (m³/h)	0.14	1.4	14
	DIN 11850	Volume flow rate range (m³/h)	0.19	1.9	19
	ISO 1127	Volume flow rate range (m³/h)	0.25	2.5	25
1½"	ASME BPE	Volume flow rate range (m³/h)	0.34	3.4	34
			± 0.08 % of full scale	± 0.4 % of measured value	
40	SMS 3008	Volume flow rate range (m³/h)	0.36	3.6	36
	DIN 11850	Volume flow rate range (m³/h)	0.41	4.1	41
	ISO 1127	Volume flow rate range (m³/h)	0.56	5.6	56
2"	ASME BPE	Volume flow rate range (m³/h)	0.64	6.4	64
			± 0.08 % of full scale	± 0.4 % of measured value	
50	SMS 3008	Volume flow rate range (m³/h)	0.67	6.7	67
	DIN 11850	Volume flow rate range (m³/h)	0.71	7.1	71
	ISO 1127	Volume flow rate range (m³/h)	0.90	9.0	90
2½"	ASME BPE	Volume flow rate range (m³/h)	1.02	10.2	102
			± 0.08 % of full scale	± 0.4 % of measured value	
65	DIN 11850	Volume flow rate range (m³/h)	1.23	12.3	123
	ISO 1127	Volume flow rate range (m³/h)	1.47	14.7	147
3"	ASME BPE	Volume flow rate range (m³/h)	1.50	15.0	150
			± 0.08 % of full scale	± 0.4 % of measured value	
80	DIN 11850	Volume flow rate range (m³/h)	1.85	18.5	185
	ISO 1127	Volume flow rate range (m³/h)	2.00	20.0	200
			± 0.08 % of full scale	± 0.4 % of measured value	

DTS 1000270652 EN Version: Y Status: RL (released | freigegeben | validé) printed: 12.04.2024

### 5.3. Refresh time table

Selectable mode	Volume flow rate	Density	Mass flow rate
Very short	~ 25 ms	1 s	~ 25 ms
Short	~ 40 ms	1 s	~ 40 ms
Long	~ 75 ms	0.5 s	~ 75 ms

## 6. Product installation

### 6.1. Installation notes

#### Flow measurement

**Note:**

The device is not suitable for use in gaseous media and steam. However, their flow does not have any negative effect on the device or its operation. Other liquids flowing through again afterwards are measured correctly as before.

The factory calibration of the FLOWave is done under reference conditions with inlet (40xDN) and outlet (1xDN) distances and the appropriate internal diameter of the pipes.

Deviation from reference conditions can be easily adjusted through the use of a built-in K factor adjustment or Teach in procedure. We can support you if necessary, please do not hesitate to contact us.

The device can be installed into either horizontal, oblique or vertical pipes. But an installation on a vertical pipe will be better to prevent air or gas bubbles inside the measurement area. **For proper operation always ensure a totally filled measurement tube.**

Conformity to 3-A and EHEDG requires an angle of at least 5° (for SMS or series A connections) or 3° (all others available connections) against horizontal to ensure complete draining however this not necessary for proper operation of the FLOWave.

The suitable pipe size can be selected using the diagram for selecting the nominal diameter of the pipe. See chapter **“6.2. Selection of the nominal diameter” on page 28.**

DTS 1000270652 EN Version: Y Status: RL (released | freigegeben | valide) printed: 12.04.2024

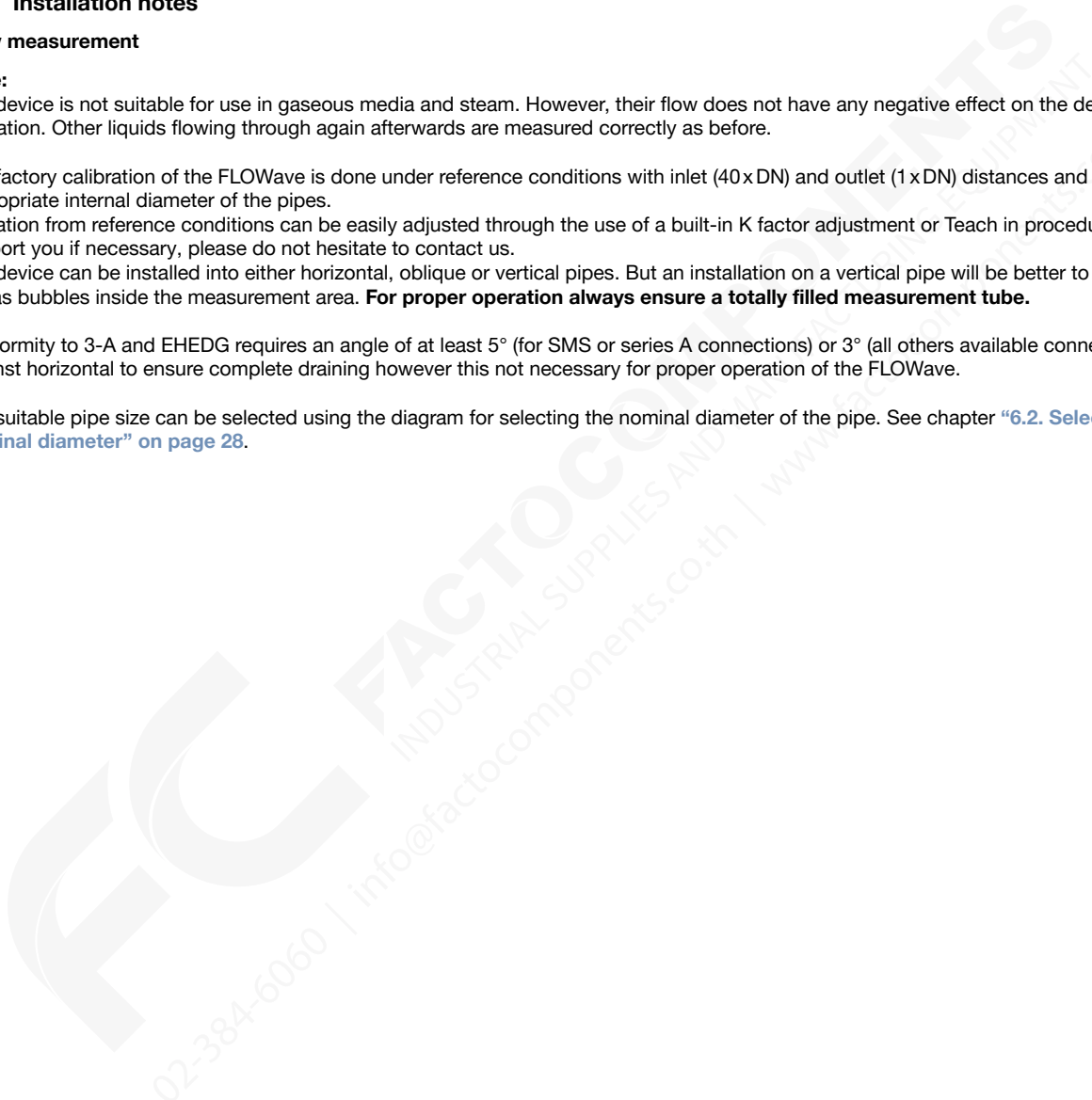

### 6.2. Selection of the nominal diameter

The following graph is used to determine the appropriate DN of the pipe and fitting for the application, according to the fluid velocity and the flow rate. On the chart, the intersection of flow velocity and flow rate gives the appropriate diameter.

**Example 1:**

Flowmeter with process connection according to DIN 32676 series B (pipe ISO 1127) or DIN 11864-2 form A series B (pipe ISO 1127)

- Nominal flow: 10 m<sup>3</sup>/h
  - Optimal flow rate: 1...3 m/s
- Result: Select a pipe size of DN 40 or DN 50

**Example 2:**

Flowmeter with process connection according to DIN 32676 series A (pipe DIN 11850) or DIN 11864-2 series A (pipe DIN 11850)

- Nominal flow: 10 m<sup>3</sup>/h
  - Optimal flow rate: 1...3 m/s
- Result: Select a pipe size of DN 40 or DN 50

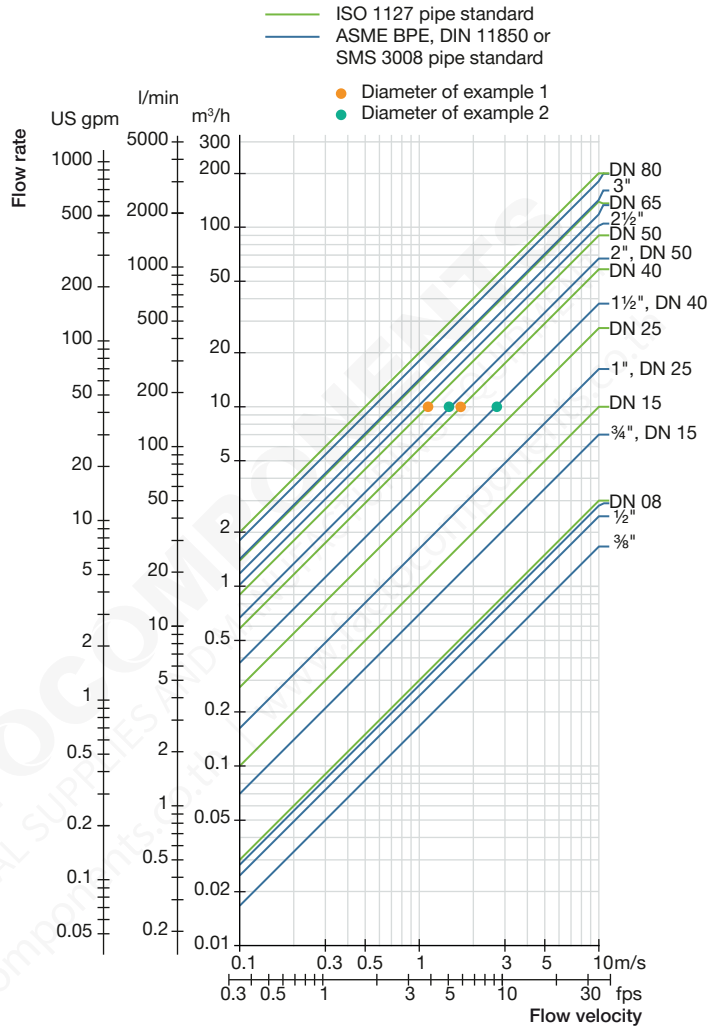

### 6.3. Mounting options

#### FLOWave L flowmeter

The product is delivered as described in position 1 in the picture below. The position of the transmitter can be changed in 90° steps. The position of the display module and the blind cover can also be changed in steps of 90° both on the top of the unit and on the front face.

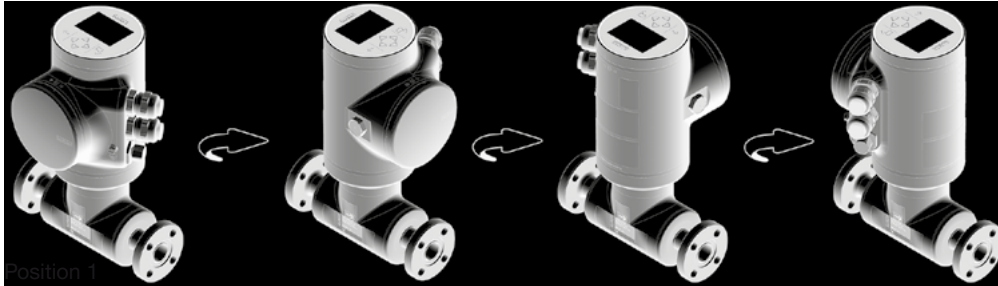

For safety reasons the display module and blind cover on the top or front are locked. The display module and blind cover can be unlocked with a magnetic key which is included in the delivery of each device.



#### FLOWave S flowmeter

The product is delivered as described in position 1 in the picture below. The position of the transmitter can be changed in 90° steps. For safety reasons the transmitter is locked. The transmitter can be unlocked with a magnetic key which is included in the delivery of each device.



## 7. Product operation

### 7.1. Measuring principle

The technology used is based on SAW (Surface Acoustic Waves). The type of wave propagation is similar to what happens when an earthquake occurs in nature.

In the case of FLOWave it is a miniaturized signal, not running on the surface of the earth but on a measurement tube. FLOWave uses so called interdigital transducers which are placed on flattened areas of the tube surface. Each one acts as emitter as well as receiver. Two of them (nos. 1 and 4) emit forward, in the direction of the liquid flow, the others (nos. 2 and 3) backwards, i.e. in the opposite direction to the direction of flow. The propagation time is measured from emitter to receiver. The difference between the forward and backward propagation time of the waves is proportional to the volume flow rate.

The high performance measurement is achieved by the following aspects:

- Each emitter sends multiple signals that are received on two other receivers
- The results are based on the reception of the signals that pass through the liquid one or more times.
- Several measurements can be performed based on the collected information. Many properties of the liquid can be derived, including the flow velocity, the fluid density, the fraction of the transmitted signal (“acoustic transmission factor”), and the so-called “differentiation factor” (see following), as well as information about the presence of gas bubbles or solid parts.
- Mass flow is calculated from fluid density and volume flow.
- Mass flow and density measurements are an option on standard FLOWave flowmeters, which requires adjustment and calibration during manufacture. It is therefore necessary to specify whether or not the device is to be equipped with these features when ordering the device.

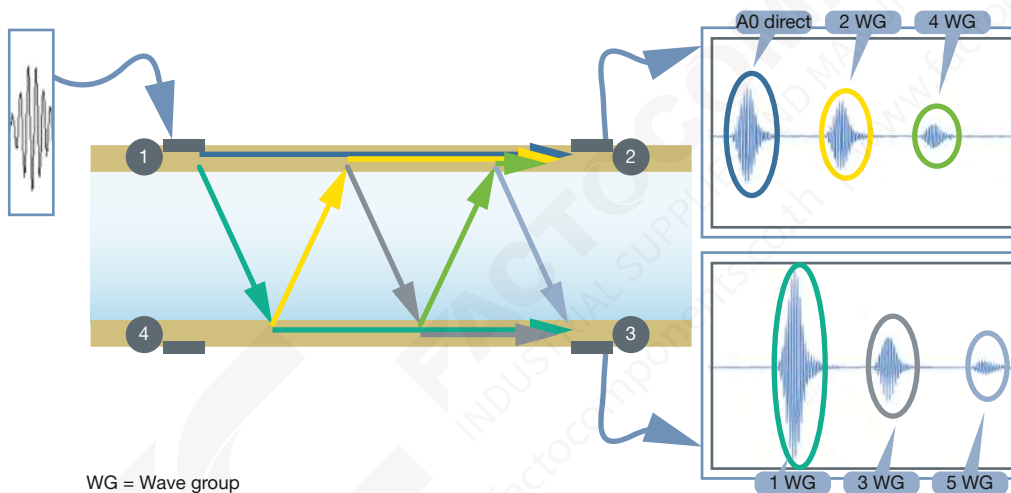

This figure shows, as an example, the reception signals when interdigital transducer 1 is transmitting. The emitter excitation produces the SAW with a frequency of more than 1 MHz.

As a result of the emission of these waves, the following effects occur:

- A wave propagates along the surface of the tube (see blue line).
- A wave is emitted (see teal green line) and passes through the liquid towards the opposite side of the tube at a certain angle, which depends mainly on the speed of propagation on the surface of the tube and in the liquid.
- Upon reaching the opposite side of the tube, two effects take place.
  - A wave is triggered in the tube and propagates (see green line) to receiver 3
  - A wave is triggered in the liquid (see yellow line) and passes through it again to the opposite wall of the tube. The analysis of the transmitted and received waves allows deriving the process values (velocity, density, flow rates).

These effects are repeated and thus generate the many signals received, which are differentiated in the image with different colours.

## 7.2. Special functions

**Note:**

DF, ATF, density, mass flow and concentration features must be selected upon initial order of device.

For the detection of gas bubbles and solid particles the device (from firmware version 01.05.00) includes a so called "acoustic transmission factor (ATF)" with a measurement range of 5...120 %, whose value is constantly recorded and directly influenced by the presence of gas bubbles and solid particles.

A "differentiation factor (DF)", with a measuring range of 0.8...1.3, is available for the detection and differentiation of liquids. This continuously measured value, which uses water as a reference fluid, is temperature-compensated and so its value is representative in a tight value range for each liquid. The changes in value of this process measurement enable differentiation between different liquids.

Before SW version 05.00.00, the differentiation factor was named density factor. As the density option has been added, the name has been changed to avoid confusion.

Beer wort extract concentration measurement ("°Plato") requires the activation of DF and ATF, on which it is based.

## 8. Product design and assembly

### 8.1. Product assembly

The 8098 flowmeter consists of a S097 flow sensor and a FLOWave L transmitter (variant FLOWave L flowmeter) or FLOWave S transmitter (variant FLOWave S flowmeter).

The flow sensor includes the measurement tube equipped with interdigital transducers, the sensor housing and the process connections in accordance to the standards ISO, ASME BPE, DIN, SMS. At present the sensor size ranges from DN 08 to DN 80 or from 3/8" to 3".

The FLOWave L flowmeter is available with or without display. The high resolution display includes a capacitive working keypad for all interactive user actions, guided by a user friendly menu system. The output signals include one analogue output and one digital output; while a third output signal can be switched between analogue and digital through parametrisation. Electrical connection is done on push-in connectors via two cable glands and/or one M12 connector.

The FLOWave S flowmeter is only available without display. The electrical connection is made via an M12 male connector.

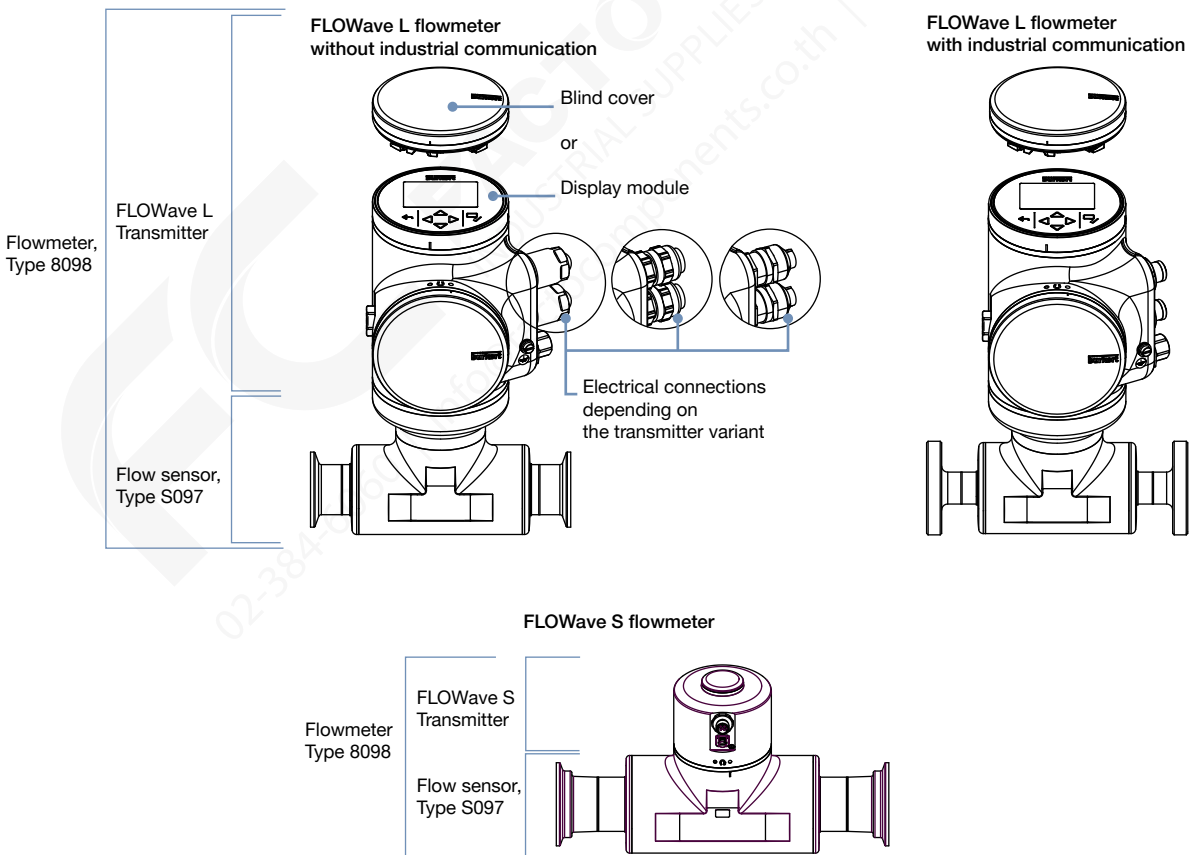



DTS 1000270652 EN Version: Y Status: RL (released | freigegeben | validé) printed: 12.04.2024

## 9. Product accessories

**Note:**

To configure a device without a display, use the USB-büS-Interface set Type 8923 and the Bürkert Communicator software Type 8920. For the FLOWave S with 2 outputs, the büS adaptor cable, article no. 773286, is also required.

See **Software manual Type 8920** ▶ for more information.

Accessories	No.	Description
<b>USB-büS-Interface set 1</b> 	1	Quick-Start
	2	Power supply: 100...240 V AC/ 24 V DC 1 A and adaptors for power supply worldwide use
	3	büS terminating resistor on büS Y-splitter
	4	5-pin M12 male connector wired on free end cable, cable length: 0.2 m
	5	büS connection cable with 5-pin M12 male connector, micro USB B plug, cable length: 0.3 m
	6	büS adaptor with 5-pin M12 male connector, A-coded to 5-pin M12 male connector, A-coded
	7	büS stick (USB to büS/CANopen adaptor)
	8	büS service cable with 5-pin M12 female connector, mini USB plug and circular female connector for power supply, cable length: 0.7 m
	9	Magnetic key
	10	CD - Communicator (30-day license without registration, update and licensing over Bürkert home page)
<b>USB-büS-Interface set 2</b> 	5	
	7	
	8	

## 10. Ordering information

### 10.1. Bürkert eShop



**Bürkert eShop – Easy ordering and quick delivery**

You want to find your desired Bürkert product or spare part quickly and order directly? Our online shop is available for you 24/7. Sign up and enjoy all the benefits.

[Order online now](#)

DTS 1000270652 EN Version: Y Status: RL (released | freigegeben | valide) printed: 12.04.2024



### 10.2. Recommendation regarding product selection

**Note:**

- The installation of the flowmeter in a pipe requires the use of counter-connection, seals, fixing elements, etc. depending on the used norm.
- The drawings show the installation with a FLOWave L variant of the flowmeter. The installation is also valid for the FLOWave S variant.

For instance with middle-sized devices:

Connection	Description
	<p><b>With clamp connection according to DIN 32676 series A</b></p> <p>To insert a FLOWave DN 40 with clamp connections according to DIN 32676 series A (with Ra &lt;0.8 µm) to a pipe according to DIN 11866 series A (DIN 11850), the <b>correct adapters to be selected and separately ordered</b> are for instance</p> <ul style="list-style-type: none"> <li>• 2x <b>BBS-25</b> clamp ferrules, article no. 747237, see <b>data sheet Type BBS-25</b> ▶ for more information</li> <li>• 2x the appropriate seals (not provided)</li> <li>• 2x the corresponding clamps, article no. 731164</li> </ul>
	<p><b>With aseptic collar flange (BF) according to DIN 11864-2 form A</b></p> <p>To insert a FLOWave DN 40 with collar flanges according to DIN 11864-2 series B (with Ra &lt;0.8 µm) to a pipe according to DIN 11866 series B (ISO 1127), the <b>correct adapters to be selected and separately ordered</b> are for instance</p> <ul style="list-style-type: none"> <li>• 2x <b>BBS-06</b> aseptic groove flange, article no. 731860, see <b>data sheet Type BBS-06</b> ▶ for more information</li> <li>• 2x the appropriate seals (not provided)</li> <li>• 8x the corresponding screws, flat washers and nuts (please refer to the DIN 11864-2 standard)</li> </ul>
	<p><b>With aseptic collar clamp (BKS) according to DIN 11864-3 form A</b></p> <p>To insert a FLOWave 1" with hygienic collar clamps according to DIN 11864-3 series C (with Ra &lt;0.8 µm) to a pipe according to DIN 11866 series C (ASME BPE), the <b>correct adapters to be selected and separately ordered</b> are for instance</p> <ul style="list-style-type: none"> <li>• 2x <b>BBS-05</b> aseptic groove clamp, article no. 730272, see <b>data sheet Type BBS-05</b> ▶ for more information</li> <li>• 2x the appropriate seals (not provided)</li> <li>• 2x the corresponding clamps, article no. 731164</li> </ul>
	<p><b>With thread according to DIN 11851</b></p> <p>To insert a FLOWave with thread according to DIN 11851 series A to a pipe according to DIN 11850, suitable adapters (not available from Bürkert) are required, for instance</p> <ul style="list-style-type: none"> <li>• 2x the conical ferrule</li> <li>• 2x the appropriate DIN 11851 seal</li> <li>• 2x the corresponding round slotted nut</li> </ul>

### 10.3. Bürkert product filter

**Bürkert product filter – Get quickly to the right product**

You want to select products comfortably based on your technical requirements? Use the Bürkert product filter and find suitable articles for your application quickly and easily.

Try out our product filter

DTS 1000270652 EN Version: Y Status: RL (released | freigegeben | valide) printed: 12.04.2024

### 10.4. Bürkert Product Enquiry Form

**Bürkert Product Enquiry Form – Your enquiry quickly and compactly**

Would you like to make a specific product enquiry based on your technical requirements? Use our Product Enquiry Form for this purpose. There you will find all the relevant information for your Bürkert contact. This will enable us to provide you with the best possible advice.

Fill out the form now

### 10.5. Bürkert 3D Model

**Applications & Tools**

CAD Model

Interactive Animation

**Bürkert 3D Model - Interactive Animation**

3D Model and Interactive Animation are available on the website of the flowmeter Type 8098. See [website of the Type 8098](#) ▶ under “Applications and Tools”.

### 10.6. Ordering chart FLOWave L flowmeter with or without industrial communication

**Clamp connection acc. to DIN 32676 series A for pipe acc. to DIN 11866 series A (DIN 11850)**

**Note:**

- To configure a device without a display, use the USB-büs interface Type 8923 (must be ordered separately, see chapter “9. Product accessories” on page 32 and “10.8. Ordering chart accessories” on page 42).
- The following variants are equipped with a display and the special functions ATF (acoustic transmission factor) and DF (differentiation factor).

Diameter <sup>1.)</sup> [mm]	Maximal flow rate [m <sup>3</sup> /h]	Dimensions <sup>2.)</sup> D2 x s; D3 [mm]	Surface quality		Approval and conformity		Article no.
			Housing, outer surface of measurement tube [µm]	Inner surface of measurement tube [µm]	3-A (28-06)	EHEDG <sup>3.)</sup>	
<b>Variant without industrial communication (2 cable glands<sup>4.)</sup> M20x1.5 and 1 x 5-pin M12 male connector), operating voltage of 12...35 V DC</b>							
08	2.8	14.0x2.0; 34.0	Ra<1.6	Ra<0.8	Yes	Yes	20047956
				Ra<0.4			574317
15	7.3	19.05x1.65; 34.0		Ra<0.8			569159
				Ra<0.4			569161
25	19	25.4x1.65; 50.5		Ra<0.8			569163
				Ra<0.4			569165
40	41	38.1x1.65; 50.5		Ra<0.8			569167
				Ra<0.4			569169
50	71	50.8x1.65; 64.0		Ra<0.8			569171
				Ra<0.4			569173
65	123	70.0x2.0; 91.0		Ra<0.8			573445
				Ra<0.4			573373
80	185	85.0x2.0; 106.0		Ra<0.8			573446
				Ra<0.4			573374

1.) = process connection size and pipe size  
 2.) Dimensions of clamp connection: D2 = external diameter (side welded to measuring tube), s = wall thickness, D3 = external diameter (clamp connection side), see chapter “4.4. Flowmeter with clamp connection” on page 21.  
 3.) The EHEDG compliance is only if used in combination with gaskets from Combifit International B.V.  
 4.) Cable glands in nickel plated brass

DTS 1000270652 EN Version: Y Status: RL (released | freigegeben | valide) printed: 12.04.2024

**Clamp connection acc. to DIN 32676 series B for pipe acc. to DIN 11866 series B (ISO 1127)**

**Note:**

- To configure a device without a display, use the USB-büS-Interface set Type 8923 (must be ordered separately, see chapter “9. Product accessories” on page 32 and “10.8. Ordering chart accessories” on page 42).
- The following variants are equipped with a display and the special functions ATF (acoustic transmission factor) and DF (differentiation factor).

Diameter <sup>1.)</sup> [mm]	Maximal flow rate [m <sup>3</sup> /h]	Dimensions <sup>2.)</sup> D2 x s; D3 [mm]	Surface quality		Approval and conformity		Article no.
			Housing, outer surface of measurement tube [µm]	Inner surface of measurement tube [µm]	3-A (28-06)	EHEDG <sup>3.)</sup>	
<b>Variant without industrial communication (2 cable glands<sup>4.)</sup> M20x1.5 and 1 x 5-pin M12 male connector), operating voltage of 12...35 V DC</b>							
08	3	14 x 1.85; 25.0	Ra < 1.6	Ra < 0.8	Yes	Yes	573126
				Ra < 0.4			573128
15	10	21.3 x 1.6; 50.5 21.3 x 1.6; 34.0 21.3 x 1.6; 50.5 21.3 x 1.6; 34.0	Ra < 1.6	Ra < 0.8	Yes	Yes	566187
				Ra < 0.4			566235
				Ra < 0.8			566195
				Ra < 0.4			566237
25	25	33.7 x 2.0; 50.5	Ra < 1.6	Ra < 0.8	Yes	Yes	566188
				Ra < 0.4			566196
40	56	48.3 x 2.0; 64.0	Ra < 1.6	Ra < 0.8	Yes	Yes	566189
				Ra < 0.4			566197
				Ra < 0.8			566190
50	90	60.3 x 2.0; 77.5	Ra < 1.6	Ra < 0.8	Yes	Yes	566198
				Ra < 0.4			566198
65	147	76.1 x 2.0; 91.0	Ra < 1.6	Ra < 0.8	Yes	Yes	573442
				Ra < 0.4			573370
80	200	88.9 x 2.3; 106.0	Ra < 1.6	Ra < 0.8	Yes	Yes	573443
				Ra < 0.4			573371

1.) = process connection size and pipe size  
 2.) Dimensions of clamp connection: D2 = external diameter (side welded to measuring tube), s = wall thickness, D3 = external diameter (clamp connection side), see chapter “4.4. Flowmeter with clamp connection” on page 21.  
 3.) The EHEDG compliance is only if used in combination with gaskets from Combit International B.V.  
 4.) Cable glands in nickel plated brass

DTS 1000270652 EN Version: Y Status: RL (released | freigegeben | validé) printed: 12.04.2024

**Clamp connection acc. to DIN 32676 series C for pipe acc. to DIN 11866 series C (ASME BPE)**

**Note:**

- To configure a device without a display, use the USB-büS-Interface set Type 8923 (must be ordered separately, see chapter “9. Product accessories” on page 32 and “10.8. Ordering chart accessories” on page 42).
- The following variants are equipped with a display and the special functions ATF (acoustic transmission factor) and DF (differentiation factor).

Diame- ter <sup>1.)</sup>	Maximal flow rate	Dimensions <sup>2.)</sup> D2 x s; D3	Surface quality		Approval and conformity			Article no.
			Housing, outer surface of measurement tube	Inner surface of measurement tube	3-A (28-06)	EHEDG <sup>3.)</sup>	UL	
[inch]	[m <sup>3</sup> /h]	[mm]	[µm]	[µm]				
<b>Variant without industrial communication (2 cable glands<sup>4.)</sup> M20x1.5 and 1 x 5-pin M12 male connector), operating voltage of 12...35 V DC</b>								
3/8	1.7	14.00x3.125; 25.0	Ra<1.6	Ra<0.8	Yes	Yes	No	573112
				Ra<0.4			Yes	573114
1/2	2.5	14.00x2.3; 25.0		Ra<0.8			No	573119
				Ra<0.4			Yes	573121
3/4	7	19.05 x 1.65; 25.0		Ra<0.8			No	566203
				Ra<0.4			Yes	566211
1	14	25.4 x 1.65; 50.5		Ra<0.8			No	569675
				Ra<0.4			Yes	566204
1 1/2	34	38.1 x 1.65; 50.5		Ra<0.8			No	566212
				Ra<0.4			Yes	569676
2	64	50.8 x 1.65; 64.0		Ra<0.8			No	566205
				Ra<0.4			Yes	566213
2 1/2	100	63.5 x 1.65; 77.5		Ra<0.8			No	566206
				Ra<0.4			Yes	569677
3	150	76.2 x 1.65; 91.0		Ra<0.8			No	573448
				Ra<0.4			Yes	573376
				Ra<0.8			No	574710
				Ra<0.4			Yes	573449
				Ra<0.8			No	573377
				Ra<0.4			Yes	574711

DTS 1000270652 EN Version: Y Status: RL (released | freigegeben | valide) printed: 12.04.2024

Diame-ter <sup>1.)</sup>	Maximal flow rate	Dimensions <sup>2.)</sup> D2 x s; D3	Surface quality		Approval and conformity			Article no.
			Housing, outer surface of measurement tube	Inner surface of measurement tube	3-A (28-06)	EHEDG <sup>3.)</sup>	UL	
[inch]	[m <sup>3</sup> /h]	[mm]	[µm]	[µm]				
<b>Variant with industrial communication (Ethernet variant, 2 x 4-pin M12 female connectors and 1 x 5-pin M12 male connector), operating voltage of 12...35 V DC</b>								
3/8	1.7	14.00x3.125; 25.0	Ra<1.6	Ra<0.4	Yes	Yes	No	573117
							Yes	573118
1/2	2.5	14.00x2.3; 25.0					No	573124
							Yes	573125
3/4	7	19.05 x 1.65; 25.0					No	570444
							Yes	569679
1	14	25.4 x 1.65; 50.5					No	570445
							Yes	569680
1 1/2	35	38.1 x 1.65; 50.5					No	570446
							Yes	569681
2	64	50.8 x 1.65; 64.0					No	570447
							Yes	569682
2 1/2	100	63.5 x 1.65; 77.5					No	574716
							Yes	574720
3	150	76.2 x 1.65; 91.0					No	574717
							Yes	574721

- 1.) = process connection size and pipe size
- 2.) Dimensions of clamp connection: D2 = external diameter (side welded to measuring tube), s = wall thickness, D3 = external diameter (clamp connection side), see chapter "4.4. Flowmeter with clamp connection" on page 21.
- 3.) The EHEDG compliance is only if used in combination with gaskets from Combifit International B.V.
- 4.) Cable glands in nickel plated brass

**Thread connection acc. to DIN 11851 series A for pipe acc. to DIN 11866 series A (DIN 11850)**

**Note:**

- To configure a device without a display, use the USB-büs-Interface set Type 8923 (must be ordered separately, see chapter "9. Product accessories" on page 32 and "10.8. Ordering chart accessories" on page 42).
- The following variants are equipped with a display and the special functions ATF (acoustic transmission factor) and DF (differentiation factor).

Diameter <sup>1.)</sup>	Maximal flow rate	Dimensions <sup>2.)</sup> D2 x s; D3	Surface quality		Approval and conformity		Article no.
			Housing, outer surface of measurement tube	Inner surface of measurement tube	3-A (28-06)	EHEDG <sup>2.)</sup>	
[mm]	[m <sup>3</sup> /h]	[mm]	[µm]	[µm]			
<b>Variant without industrial communication (2 cable glands<sup>4.)</sup> M20x1.5 and 1 x 5-pin M12 male connector), operating voltage of 12...35 V DC</b>							
65	123	70.0x2.0; Rd 95 x 1/6	Ra<1.6	Ra<0.8	Yes	Yes	573463
80	185	85.0x2.0; Rd 110 x 1/4					Ra<0.8

- 1.) = process connection size and pipe size
- 2.) D2 for holder; s = thickness; D3: thread connection
- 3.) The EHEDG compliance is s only valid if used in combination with EHEDG-compliant gaskets from
  - Kieselmann GmbH, Germany (ASEPTO-STAR k-flex upgrade gaskets) or
  - Siersema Componenten Service (S.K.S.) B.V. (Netherlands SKS gasket set DIN 11851 EHEDG with EPDM or FKM inner gasket).
- 4.) Cable glands in nickel plated brass

DTS 1000270652 EN Version: Y Status: RL (released | freigegeben | validé) printed: 12.04.2024

Further variant on request	
<p><b>Process connection</b></p> <ul style="list-style-type: none"> <li>For pipe DIN 11850:                             <ul style="list-style-type: none"> <li>Clamp DIN 11864-3</li> <li>Flange DIN 11864-2</li> </ul> </li> <li>For pipe ISO 1127:                             <ul style="list-style-type: none"> <li>Clamp DIN 11864-3</li> <li>Flange DIN 11864-2</li> </ul> </li> <li>For pipe ASME BPE:                             <ul style="list-style-type: none"> <li>Clamp DIN 11864-3</li> <li>Flange DIN 11864-2</li> </ul> </li> <li>For pipe SMS 3008: SMS 3017</li> </ul>	<p><b>Additional</b></p> <ul style="list-style-type: none"> <li>With/without display</li> <li>Without differentiation factor (DF)</li> <li>Without acoustic transmission factor (ATF)</li> <li>With density and mass flow</li> <li>With original gravity measurement (degree Plato)</li> <li>Ethernet module (EtherNet/IP, PROFINET, Modbus TCP/IP, ETHCAT)</li> <li>ATEX/IECEX</li> </ul> <p><b>Material</b></p> <ul style="list-style-type: none"> <li>With inner surface of measurement tube                             <ul style="list-style-type: none"> <li>Ra &lt; 0.8 µm (30 µin.)</li> <li>Ra &lt; 0.4 µm (15 µin.) (electro-polished) according to ISO 4288</li> </ul> </li> </ul>
<p><b>Orifice</b></p> <ul style="list-style-type: none"> <li>08...80 mm</li> <li>¾...3 inch</li> </ul>	<p><b>Electrical connection</b></p> <p>Cable gland in stainless steel</p>

For any other variants, use the product enquiry form, see chapter "10.4. Bürkert Product Enquiry Form" on page 34 or check the readily available article no. listed in the Bürkert eShop.

### 10.7. Ordering chart FLOWave S flowmeter

Clamp connection acc. to DIN 32676 series A for pipe acc. to DIN 11866 series A (DIN 11850)

**Note:**

The following variants are equipped with the special functions ATF (acoustic transmission factor) and DF (differentiation factor).

Diameter <sup>1.)</sup>	Maximal flow rate	Dimensions <sup>2.)</sup> D2 x s; D3	Surface quality		Approval and conformity		Article no.
			Housing, outer surface of measurement tube	Inner surface of measurement tube	3-A (28-06)	EHEDG <sup>3.)</sup>	
[mm]	[m³/h]	[mm]	[µm]	[µm]	3-A (28-06)	EHEDG <sup>3.)</sup>	
<b>Electrical connection: 1 x 8-pin M12 male connector, operating voltage of 12...35 V DC</b>							
65	123	70.0 x 2.0; 91.0	Ra < 1.6	Ra < 0.8	Yes	Yes	574689
				Ra < 0.4			573421
80	185	85.0 x 2.0; 106.0	Ra < 1.6	Ra < 0.8	Yes	Yes	574690
				Ra < 0.4			573422

1.) = process connection size and pipe size

2.) Dimensions of clamp connection: D2 = external diameter (side welded to measuring tube), s = wall thickness, D3 = external diameter (clamp connection side), see chapter "4.4. Flowmeter with clamp connection" on page 21.

3.) The EHEDG compliance is only if used in combination with gaskets from Combifit International B.V.

DTS 1000270652 EN Version: Y Status: RL (released | freigegeben | validé) printed: 12.04.2024

**Clamp connection acc. to DIN 32676 series B for pipe acc. to DIN 11866 series B (ISO 1127)**

**Note:**

The following variants are equipped with the special functions ATF (acoustic transmission factor) and DF (differentiation factor).

Diameter <sup>1.)</sup> [mm]	Maximal flow rate [m <sup>3</sup> /h]	Dimensions <sup>2.)</sup> D2 x s; D3 [mm]	Surface quality		Approval and conformity		Article no.
			Housing, outer surface of measurement tube [µm]	Inner surface of measurement tube [µm]	3-A (28-06)	EHEDG <sup>3.)</sup>	
<b>Electrical connection: 1 x 5-pin M12 male connector, operating voltage of 12...35 V DC</b>							
08	3	14 x 1.85; 25.0	Ra < 1.6	Ra < 0.8	Yes	Yes	573716
				Ra < 0.4			573717
15	10	21.3 x 1.6; 50.5 21.3 x 1.6; 34.0 21.3 x 1.6; 50.5 21.3 x 1.6; 34.0	Ra < 1.6	Ra < 0.8	Yes	Yes	573093
				Ra < 0.4			573094
				Ra < 0.8			573098
				Ra < 0.4			573099
25	25	33.7 x 2.0; 50.5	Ra < 1.6	Ra < 0.8	Yes	Yes	573095
				Ra < 0.4			573100
40	56	48.3 x 2.0; 64.0	Ra < 1.6	Ra < 0.8	Yes	Yes	573096
				Ra < 0.4			573101
50	90	60.3 x 2.0; 77.5	Ra < 1.6	Ra < 0.8	Yes	Yes	573097
				Ra < 0.4			573102
<b>Electrical connection: 1 x 8-pin M12 male connector, operating voltage of 12...35 V DC</b>							
08	3	14 x 1.85; 25.0	Ra < 1.6	Ra < 0.8	Yes	Yes	571780
				Ra < 0.4			571781
15	10	21.3 x 1.6; 50.5 21.3 x 1.6; 34.0 21.3 x 1.6; 50.5 21.3 x 1.6; 34.0	Ra < 1.6	Ra < 0.8	Yes	Yes	571782
				Ra < 0.4			571783
				Ra < 0.8			571784
				Ra < 0.4			571785
25	25	33.7 x 2.0; 50.5	Ra < 1.6	Ra < 0.8	Yes	Yes	571786
				Ra < 0.4			571787
40	56	48.3 x 2.0; 64.0	Ra < 1.6	Ra < 0.8	Yes	Yes	571788
				Ra < 0.4			571789
50	90	60.3 x 2.0; 77.5	Ra < 1.6	Ra < 0.8	Yes	Yes	571790
				Ra < 0.4			571791
65	147	76.1 x 2.0; 91.0	Ra < 1.6	Ra < 0.8	Yes	Yes	574686
80	200	88.9 x 2.3; 106.0	Ra < 1.6	Ra < 0.8	Yes	Yes	573418
				Ra < 0.4			574687
				Ra < 0.4			573419

1.) = process connection size and pipe size

2.) Dimensions of clamp connection: D2 = external diameter (side welded to measuring tube), s = wall thickness, D3 = external diameter (clamp connection side), see chapter "4.4.

Flowmeter with clamp connection" on page 21.

3.) The EHEDG compliance is only if used in combination with gaskets from Combifit International B.V.

DTS 1000270652 EN Version: Y Status: RL (released | freigegeben | validé) printed: 12.04.2024

Clamp connection acc. to DIN 32676 series C for pipe acc. to DIN 11866 series C (ASME BPE)

Note:

The following variants are equipped with the special functions ATF (acoustic transmission factor) and DF (differentiation factor).

Diame- ter <sup>1.)</sup>	Maximal flow rate	Dimensions <sup>2.)</sup> D2 x s; D3	Surface quality		Approval and conformity			Article no.
			Housing, outer surface of measurement tube	Inner surface of measurement tube	3-A (28-06)	EHEDG <sup>3.)</sup>	UL	
[inch]	[m <sup>3</sup> /h]	[mm]	[µm]	[µm]				
<b>Electrical connection: 1 x 5-pin M12 male connector, operating voltage of 12...35 V DC</b>								
¾	1.7	14.00 x 3.125; 25.0	Ra < 1.6	Ra < 0.8	Yes	Yes	No	573710
				Ra < 0.4			Yes	573711
½	2.5	14.00 x 2.3; 25.0		Ra < 0.8			No	573712
				Ra < 0.4			Yes	573713
¾	7	19.05 x 1.65; 25.0		Ra < 0.8			No	573714
				Ra < 0.4			Yes	573715
1	14	25.4 x 1.65; 50.5		Ra < 0.8			No	573085
				Ra < 0.4			Yes	573086
1½	35	38.1 x 1.65; 50.5		Ra < 0.8			No	573087
				Ra < 0.4			Yes	573088
2	64	50.8 x 1.65; 64.0		Ra < 0.8			No	573089
				Ra < 0.4			Yes	573090
<b>Electrical connection: 1 x 8-pin M12 male connector, operating voltage of 12...35 V DC</b>								
¾	1.7	14.00 x 3.125; 25.0	Ra < 1.6	Ra < 0.8	Yes	Yes	No	571792
				Ra < 0.4			Yes	571793
½	2.5	14.00 x 2.3; 25.0		Ra < 0.8			No	571794
				Ra < 0.4			Yes	571795
¾	7	19.05 x 1.65; 25.0		Ra < 0.8			No	571796
				Ra < 0.4			Yes	571797
1	14	25.4 x 1.65; 50.5		Ra < 0.8			No	571798
				Ra < 0.4			Yes	571799
1½	35	38.1 x 1.65; 50.5		Ra < 0.8			No	571800
				Ra < 0.4			Yes	571801
2	64	50.8 x 1.65; 64.0		Ra < 0.8			No	571802
				Ra < 0.4			Yes	571803
2½	100	63.5 x 1.65; 77.5		Ra < 0.8			No	571804
				Ra < 0.4			Yes	571805
3	150	76.2 x 1.65; 91.0		Ra < 0.8			No	571806
				Ra < 0.4			Yes	571807
				Ra < 0.8			No	571808
				Ra < 0.4			Yes	571809
				Ra < 0.8			No	571810
				Ra < 0.4			Yes	571811

1.) = process connection size and pipe size  
 2.) Dimensions of clamp connection: D2 = external diameter (side welded to measuring tube), s = wall thickness, D3 = external diameter (clamp connection side), see chapter "4.4. Flowmeter with clamp connection" on page 21.  
 3.) The EHEDG compliance is only if used in combination with gaskets from Combifit International B.V.

DTS 1000270652 EN Version: Y Status: RL (released | freigegeben | validé) printed: 12.04.2024



Thread connection acc. to DIN 11851 series A for pipe acc. to DIN 11866 series A (DIN 11850)

**Note:**

The following variants are equipped with the special functions ATF (acoustic transmission factor) and DF (density factor).

Diameter <sup>1.)</sup> [mm]	Maximal flow rate [m <sup>3</sup> /h]	Dimensions <sup>2.)</sup> D2 x s; D3 [mm]	Surface quality		Approval and conformity		Article no.
			Housing, outer surface of measurement tube [µm]	Inner surface of measurement tube [µm]	3-A (28-06)	EHEDG <sup>3.)</sup>	
<b>Electrical connection: 1 x 8-pin M12 male connector, operating voltage of 12...35 V DC</b>							
65	123	70.0x2.0; Rd 95 x 1/6	Ra < 1.6	Ra < 0.8	Yes	Yes	574707
80	185	85.0x2.0; Rd 110 x 1/4		Ra < 0.8			574708

1.) = process connection size and pipe size

2.) D2 for holder; s = thickness; D3: thread connection

3.) The EHEDG compliance is only valid if used in combination with EHEDG-compliant gaskets from

- Kieselmann GmbH, Germany (ASEPTO-STAR k-flex upgrade gaskets) or
- Siersema Componenten Service (S.K.S.) B.V. (Netherlands SKS gasket set DIN 11851 EHEDG with EPDM or FKM inner gasket).

**Further variants on request**

<p><b>Process connection</b></p> <ul style="list-style-type: none"> <li>• For pipe DIN 11850:                     <ul style="list-style-type: none"> <li>- Clamp DIN 32676</li> <li>- Clamp DIN 11864-3</li> <li>- Flange DIN 11864-2</li> </ul> </li> <li>• For pipe ISO 1127:                     <ul style="list-style-type: none"> <li>- Clamp DIN 11864-3</li> <li>- Flange DIN 11864-2</li> </ul> </li> <li>• For pipe ASME BPE:                     <ul style="list-style-type: none"> <li>- Clamp DIN 11864-3</li> <li>- Flange DIN 11864-2</li> </ul> </li> <li>• For pipe SMS 3008: SMS 3017</li> </ul>	<p><b>Orifice</b></p> <ul style="list-style-type: none"> <li>• 08...80 mm</li> <li>• 3/16...3 inch</li> </ul>
	<p><b>Additional</b></p> <ul style="list-style-type: none"> <li>• Without differentiation factor (DF)</li> <li>• Without acoustic transmission factor (ATF)</li> <li>• With density and mass flow</li> <li>• With original gravity measurement (degree Plato)</li> <li>• ATEX/IECEx</li> </ul>
	<p><b>Material</b></p> <ul style="list-style-type: none"> <li>• With inner surface of measurement tube                     <ul style="list-style-type: none"> <li>- Ra &lt; 0.8 µm (30 µin.)</li> <li>- Ra &lt; 0.4 µm (15 µin.) (electro-polished) according to ISO 4288</li> </ul> </li> </ul>
	<p><b>Electrical connection</b></p> <ul style="list-style-type: none"> <li>• 1 x 5-pin M12 male connector</li> <li>• 1 x 8-pin M12 male connector</li> </ul>

For any other variants, use the product enquiry form, see chapter "10.4. Bürkert Product Enquiry Form" on page 34 or check the readily available article no. listed in the Bürkert eShop.

DTS 1000270652 EN Version: Y Status: RL (released | freigegeben | validé) printed: 12.04.2024

10.8. Ordering chart accessories

Description	Article no.
Type ME31 display module	265468
Blind cover in stainless steel 304/1.4301	265467
Magnetic key for unlocking	690309
<b>System Connect</b>	
<b>Type ME43 Gateway/Interface</b>	
Industrial Ethernet gateway (PROFINET IO, EtherNet/IP, Modbus TCP, EtherCAT®)	307390
PROFIBUS gateway (PROFIBUS DPV1)	307393
<b>Type ME61 Display</b>	
FieldConnect ME61 3.5" display (8.9 cm)	368544
<b>EDIP Accessories</b>	
<b>USB-büS-Interface set</b>	
USB-büS-Interface set 1 (Type 8923) Further information can be found in chapter "9. Product accessories" on page 32.	772426
USB-büS-Interface set 2 (Type 8923) Further information can be found in chapter "9. Product accessories" on page 32.	772551
<b>Connectors</b>	
büS M12 female connector, 5-pin, straight, A-coded	772416
büS M12 male connector, 5-pin, straight, A-coded	772417
büS M12 female connector, 5-pin, angled, A-coded	772418
büS M12 male connector, 5-pin, angled, A-coded	772419
büS Y-distributor (M12 female connector, 5-pin to M12 male and female connectors, 5-pin)	772420
büS Y-distributor with power interrupt (M12 female connector, 5-pin to M12 male and female connectors, 5-pin)	772421
büS adaptor (M12 male connector, 5-pin, A-coded to M12 male connector, 5-pin, A-coded)	772867
büS terminating resistor 120 ohms, M12 male connector, 5-pin	772424
büS terminating resistor 120 ohms, M12 female connector, 5-pin	772425
<b>Connectors with cable</b>	
Adaptor cable with M12 female connector, 8-pin to M12 male connector, 5-pin	0.5 m 773286
M12 female connector, 5-pin, angled, moulded on büS cable, with open leads	0.7 m 772626
M12 female connector, 5-pin, straight, moulded on büS cable, with open leads	1 m 772409
	3 m 772410
	5 m 772411
	10 m 772412
M12 male connector, 5-pin straight and micro USB connector, moulded on büS cable	0.3 m 773254
M12 female connector, 8-pin, straight, moulded on büS cable, with open leads	2 m 919061
<b>Extensions</b>	
M12 female and male connectors, 5-pin, straight, moulded on büS cable, shielded	0.1 m 772492
	0.2 m 772402
	0.5 m 772403
	1 m 772404
	3 m 772405
	5 m 772406
	10 m 772407
20 m 772408	
<b>Power supply unit for standard rail Type 1573</b>	
100...240 V AC / 24 V DC, 1 A (Class 2 according to NEC)	772361
100...240 V AC / 24 V DC, 2 A (Class 2 according to NEC)	772362
100...240 V AC / 24 V DC, 3.8 A (Class 2 according to NEC)	772898
100...240 V AC / 24 V DC, 10 A	772698

DTS 1000270652 EN Version: Y Status: RL (released | freigegeben | valide) printed: 12.04.2024