



Radar level meter for liquids suitable for use in applications with aggressive fluids as well as with hygienic requirements

- Continuous level measurement up to 30 m, 4...20 mA, 2-wire
- Available process connections: Plastic horn antenna, thread (G, NPT ¾ and 1½), flange (DN50, DN100), clamp (2")
- Excellent radar signal focusing and high measurement dynamics
- Adjustable using the display/configuration module and keys, alternatively via PC-Tool with DTM

Product variants described in the data sheet may differ from the product presentation and description.

Can be combined with

	Type 8619 ▶ multiCELL - Multi-channel and multi-function transmitter/controller
	Type 8611 ▶ eCONTROL - Universal controller
	Type 8692 ▶ Digital electropneumatic Positioner for the integrated mounting on process control valves
	Type 8644 ▶ Remote Process Actuation Control System AirLINE

Type description

The Type 8139 is a non-contact radar level measuring device for continuous level measurement.

It is available with:

- integrated antenna (G- or NPT connection), especially suitable for level measurement of aggressive liquids, with special advantages for small vessels.
- plastic horn antenna (with mounting bracket), especially suitable for measurements in open flumes or gauge measurement in water.
- flange connection (DIN 2501) with encapsulated antenna system,
- clamp connection (DIN 32676, ISO 2852) with encapsulated antenna system for hygienic requirements.

The high focus of the radar signal and the high measurement dynamics allow excellent measurement results even in small, narrow and high containers, as the risk of signal interference by installations, constructions and vessel walls is much lowered. Signal damping, e.g. due to signal running length, foam build-up, low DK values of the liquids, has a much smaller effect.



Table of contents

1. General technical data	3
2. Product versions	5
2.1. Plastic horn antenna 80 mm	5
2.2. Thread with integrated antenna 40 mm	5
2.3. Flange with encapsulated antenna system.....	6
2.4. Hygiene connection with encapsulated antenna system	6
3. Approvals	7
3.1. ATEX-Certification.....	7
4. Materials	7
4.1. Chemical Resistance Chart – Bürkert resistApp.....	7
5. Dimensions	8
5.1. Plastic horn antenna 80 mm	8
5.2. Thread with integrated antenna 40 mm	9
5.3. Flange with encapsulated antenna system.....	10
5.4. Hygiene connection with encapsulated antenna system	11
6. Performance specifications	11
6.1. Measurement deviation diagram	11
6.2. Temperature derating diagram.....	12
Plastic horn antenna 80 mm	12
Thread with integrated antenna 40 mm	12
Flange with encapsulated antenna system.....	12
7. Product installation	13
7.1. Mounting options.....	13
Plastic horn antenna 80 mm with mounting bracket	13
Plastic horn antenna 80 mm with flange.....	13
8. Product operation	14
8.1. Measuring principle	14
8.2. Product operation notes	15
Set up with display/configuration module	15
Set up with PACTware™/DTM and HART communication.....	15
9. Product accessories	16
10. Ordering information	17
10.1. Bürkert eShop – Easy ordering and quick delivery.....	17
10.2. Bürkert product filter.....	17
10.3. Ordering chart.....	17
10.4. Ordering chart accessories.....	18

1. General technical data

Product properties

Materials

Please make sure the device materials are compatible with the fluid you are using. Detailed information can be found in chapter [“4.1. Chemical Resistance Chart – Bürkert resistApp”](#) on page 7.

Non wetted parts

Depending on antenna system. Detailed information can be found in chapter [“2. Product versions”](#) on page 5.

Housing	Plastic PBT (Polyester), PPS and stainless steel 316L (1.4404)
Cover	PC transparent
Seal between housing and housing cover	EPDM
Cable gland	PA
Blind plug	PA
Ground terminal	Stainless steel 316L

Wetted parts

Depending on antenna system. Detailed information can be found in chapter [“2. Product versions”](#) on page 5.

Dimensions	Detailed information can be found in chapter “5. Dimensions” on page 8.
Weights	Approx. 2...17.2 kg (depending on process connection and antenna)
Measuring variable	Distance between the end of the sensor antenna and the product surface.
Measuring range	Max. 30 m (depending on antenna system). Detailed information can be found in chapter “2. Product versions” on page 5.
Beam angle ^{1.)}	Depending on antenna system. Detailed information can be found in chapter “2. Product versions” on page 5.
Damping (63 % of the input variable)	0...999 s, adjustable
Step response time ^{2.)3.)}	≤3 s

Product accessories

Display	LCD in full dot matrix (optional, must be ordered separately)
---------	---

Performance data

Blocking distance	Null
Measurement deviation	According to EN 60770-1: ≤1 mm for liquids (measuring distance >0.25 m). Detailed information can be found in chapter “6.1. Measurement deviation diagram” on page 11.
Measuring range resolution	1 mm
Measuring frequency	W-Band (80 GHz technology)
Measuring cycle time ^{2.)}	Approx. 700 ms
Temperature drift	<0.03 %/10K relating to the 16 mA span or max. 0.3 %
Repeatability ^{4.)}	≤1 mm
Vibration resistance	Depending on antenna system. Detailed information can be found in chapter “2. Product versions” on page 5.
Shock resistance	100 g, 6 ms according to EN 60068-2-27 (mechanical shock)

Electrical data

Operating voltage (U_n)	12...35 V DC
Starting current	≤3.6 mA; ≤10 mA for 5 ms after switching on
Load resistor	$(U_n - U_{min})/0.022$ A
Output signal	4...20 mA/HART
Signal resolution	0.3 μ A
Range of the output signal	3.8...20.5 mA/HART (default setting)
Fault signal	Current output: mA value unchanged, 20.5 mA, 22 mA or <3.6 mA (adjustable)
Max. output current	22 mA
Residual ripple (at DC)	For 12 V < U_n < 18 V: ≤0.7 V_{eff} (16...400 Hz) For 18 V < U_n < 35 V: ≤1.0 V_{eff} (16...400 Hz)
Voltage supply cable	<ul style="list-style-type: none"> Cable diameter: 5...9 mm Wire cross-section (spring-loaded terminals): <ul style="list-style-type: none"> – massive wire, stranded wire: 0.2...2.5 mm² (AWG 24...14) – stranded wire with end sleeve: 0.2...1.5 mm² (AWG 24...16)

Media data

Process temperature	Depending on antenna system. Detailed information can be found in chapter “2. Product versions” on page 5.
---------------------	--

Process pressure	Depending on antenna system. Detailed information can be found in chapter "2. Product versions" on page 5.
------------------	---

Process/Port connection & communication

Process connection	<ul style="list-style-type: none"> • Mounting bracket 170 mm (supplied as standard) or 300 mm (accessory) (version with plastic horn antenna) • Thread G or NPT - ¾" or 1½" (version with integrated horn antenna) • Flange DN50, DN100 DIN 2501 (version with encapsulated antenna system) • Clamp 2" DIN 32676, ISO 2852 (hygiene connection version with encapsulated antenna system)
--------------------	--

Electrical connection	Cable gland M20 x 1.5
-----------------------	-----------------------

Approvals and Certificates

Standards

Degree of protection according to IEC/EN 60529	IP66/IP67 with cable plug mounted and tightened M20x 1.5
Overvoltage category according to IEC 61010-1	Category III
Protection class according to IEC 61010-1	Class III

Directives

CE directives	The applied standards, which verify conformity with the EU Directives, can be found on the EU Type Examination Certificate and/or the EU Declaration of conformity (if applicable)
NAMUR recommendations	<p>NE21 - Electromagnetic compatibility of equipment</p> <p>NE43 - Signal level for fault information from measuring transducers</p> <p>NE53 - Compatibility of field devices and display/adjustment components</p> <p>NE107 - Self-monitoring and diagnosis of field devices</p>

Approvals

ATEX/IECEx	EN IEC 60079-0, EN 60079-11, EN 60079-26 Detailed information can be found in chapter "3.1. ATEX/IECEx-Certification" on page 7.
------------	--

Environment and installation

Ambient temperature	Operation and storage: -40...+80 °C (-40...+176 °F)
Temperature derating	Depending on antenna system. Detailed information can be found in chapter "6.2. Temperature derating diagram" on page 12.
Relative air humidity	20...85 %, without condensation
Height above sea level	By default: max. 2000 m With connected overvoltage protection: max. 5000 m
Pollution degree	Degree 4 (when used with fulfilled housing protection)

- 1.) Outside the specified beam angle, the energy level of the radar signal is 50 % (-3 dB) less
- 2.) With operating voltage $U_n \geq 24$ V DC
- 3.) Time span after a sudden distance change from 1...5 m until the output signal reaches 90 % of the final value for the first time (IEC 61298-2).
- 4.) Already included in the measurement deviation

2. Product versions

2.1. Plastic horn antenna 80 mm

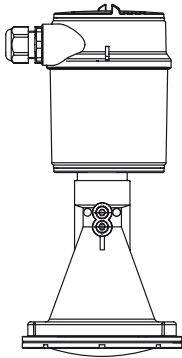

Product details	
Material	Non wetted parts: <ul style="list-style-type: none"> • antenna cone in PBT-GF 30 • mounting bracket and fixing screws, in stainless steel 316L Wetted parts: <ul style="list-style-type: none"> • focus lens in PP
Beam angle	3°
Measuring range	0...30 m
Vibration resistance	<ul style="list-style-type: none"> • With mounting bracket: 1 g with 5...200 Hz according to EN 60068-2-6 (vibration at resonance) • With adapter flange (as an option): 2 g with 5...200 Hz according to EN 60068-2-6 (vibration at resonance)
Process temperature	-40...+80 °C (-40...+176 °F)
Process pressure	With adapter flange: -1...1 bar (-100...100 kPa/-14.5...14.5 psig)
Accessories	
Material	Non wetted parts: <ul style="list-style-type: none"> • fixing screws for adapter flange in stainless steel 304 Wetted parts: <ul style="list-style-type: none"> • adapter flange for PP-GF30 black • seal for adapter flange in FKM (COG VI500)

2.2. Thread with integrated antenna 40 mm

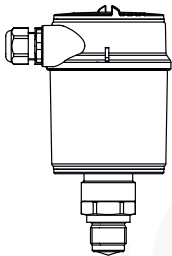

Product details	
Material	Wetted parts: <ul style="list-style-type: none"> • process connection in stainless steel 316L • antenna in PEEK • seal Antenna system in FKM • process seal in NBR with aramid fibres
Beam angle	<ul style="list-style-type: none"> • 14° for version G ¾ or NPT ¾ • 7° for version G 1½ or NPT 1½
Measuring range	<ul style="list-style-type: none"> • 0...10 m for version G ¾ or NPT ¾ • 0...20 m for version G 1½ or NPT 1½
Vibration resistance	4 g with 5...200 Hz according to EN 60068-2-6 (vibration at resonance)
Process temperature ¹⁾	-40...+130 °C (-40...+266 °F)
Process pressure	-1...20 bar (-100...2000 kPa/-14.5...290.1 psig)

1.) Take into account reduced ambient temperature. Detailed information can be found in chapter "6.2. Temperature derating diagram" on page 12

2.3. Flange with encapsulated antenna system

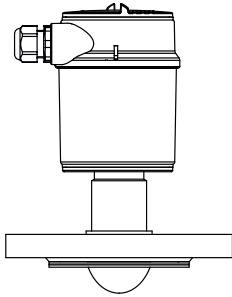

Product details	
Material	Wetted parts: <ul style="list-style-type: none"> • flange plating, antenna encapsulation in PTFE • seal in PTFE
Beam angle	<ul style="list-style-type: none"> • 6° for version DN50 • 3° for version DN100
Measuring range	<ul style="list-style-type: none"> • 0...25 m for version DN50 • 0...30 m for version DN100
Vibration resistance	4 g with 5...200 Hz according to EN 60068-2-6 (vibration at resonance)
Process temperature ^{1.)}	-40...+130 °C (-40...+266 °F)
SIP process temperature	+150 °C (+302 °F), vapour stratification up to 2 h
Process pressure	-1...16 bar (-100...1600 kPa/-14.5...232 psig)

1.) Take into account reduced ambient temperature. Detailed information can be found in chapter "6.2. Temperature derating diagram" on page 12

2.4. Hygiene connection with encapsulated antenna system

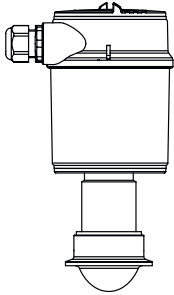

Product details	
Material	Wetted parts: <ul style="list-style-type: none"> • hygienic antenna encapsulation in PTFE • seal in PTFE
Surface roughness of the antenna encapsulation	Ra < 0.8 µm
Beam angle	6°
Measuring range	0...25 m
Process temperature	-40...+130 °C (-40...+266 °F)
SIP Process temperature	+150 °C (+302 °F), vapour stratification up to 2 h
Process pressure	-1...16 bar (-100...1600 kPa/-14.5...232 psig)

3. Approvals

3.1. ATEX/IECEX-Certification

Note:

Devices with Ex certification have different technical data, see **Supplement ATEX/IECEX Type 8139** ▶ under user manual.

Certificate	Description
	<p>EU-Type Examination Certificate Number: PTB 20 ATEX 2003X / IECEX PTB 20 ATEX 2003X</p> <p>ATEX</p> <ul style="list-style-type: none"> • II 1G Ex ia IIC T6...T1 Ga • II 1/2G Ex ia IIC T6...T1 Ga/Gb • II 2G Ex ia IIC T6...T1 Gb <p>IECEX</p> <ul style="list-style-type: none"> • Ex ia IIC T6...T1 Ga • Ex ia IIC T6...T1 Ga/Gb • Ex ia IIC T6...T1 Gb <p>Measures to comply with ATEX/IECEX requirements: refer to the Supplement ATEX/IECEX Type 8139 ▶ under user manual. The Ex. certification is only valid if the Bürkert device is used as described in the supplement ATEX/IECEX. If unauthorized changes are made to the device, the Ex. certification becomes invalid.</p>

4. Materials

4.1. Chemical Resistance Chart – Bürkert resistApp

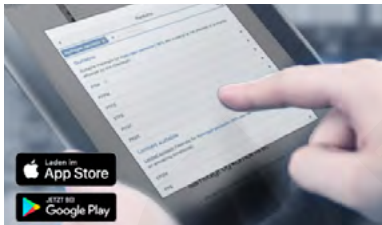

Bürkert resistApp – Chemical Resistance Chart

You want to ensure the reliability and durability of the materials in your individual application case? Verify your combination of media and materials on our website or in our resistApp.

[Start Chemical Resistance Check](#)

5. Dimensions

5.1. Plastic horn antenna 80 mm

Note:

Specifications in mm

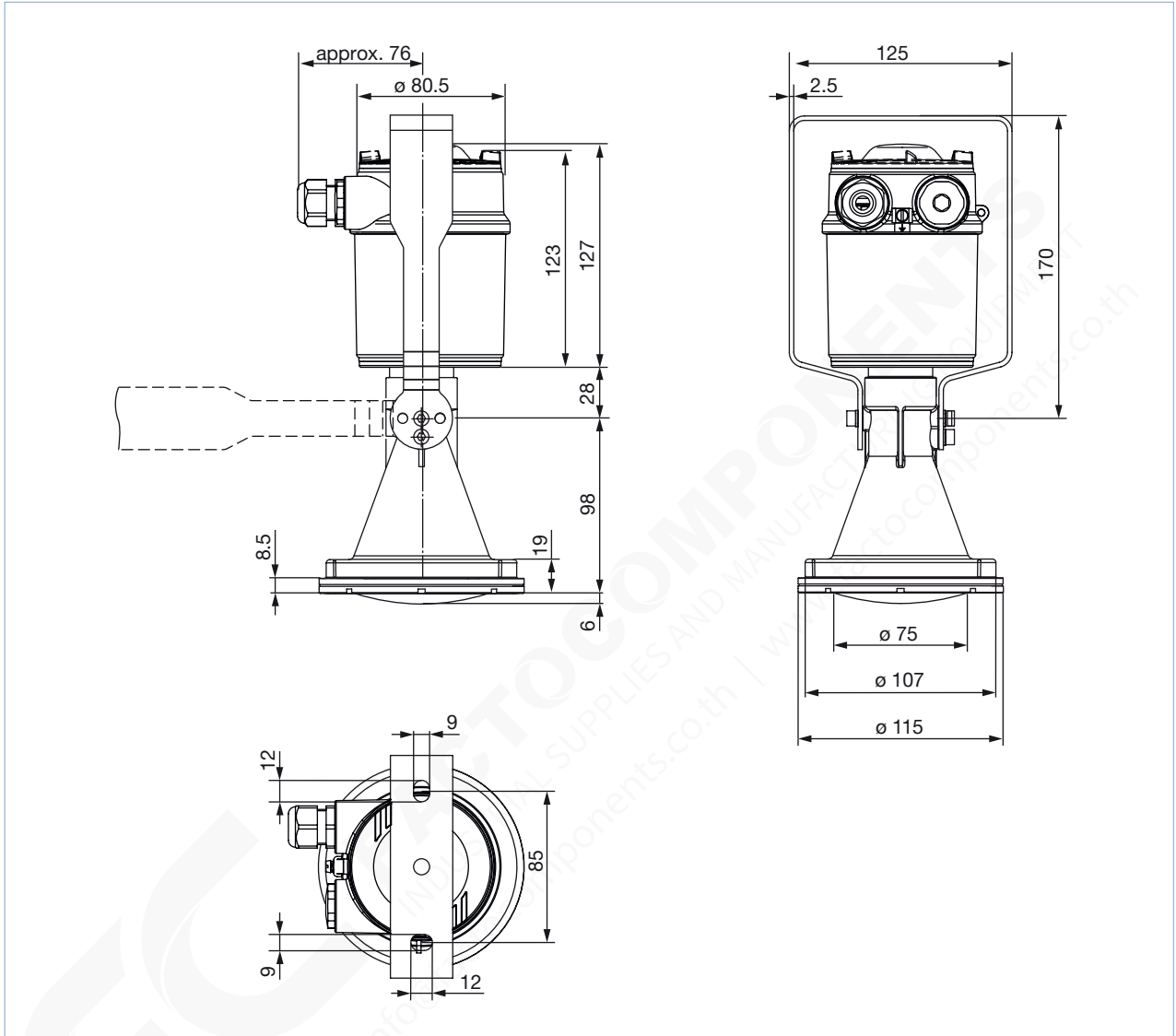

5.2. Thread with integrated antenna 40 mm

Note:
Specifications in mm

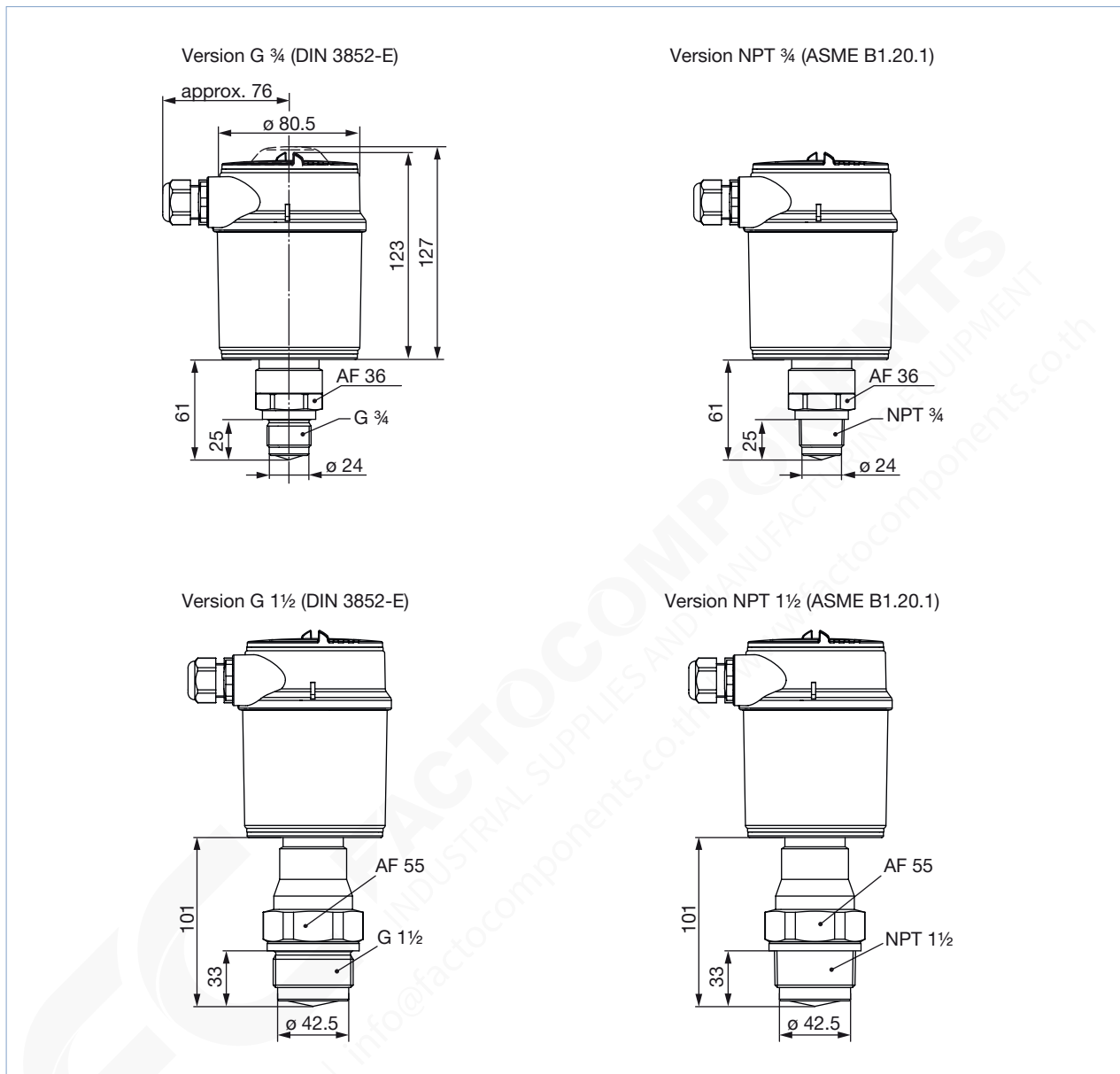

DTS 1000385105 EN Version: C Status: RL (released | freigegeben | valide) printed: 15.09.2021

5.3. Flange with encapsulated antenna system

Note:

Specifications in mm

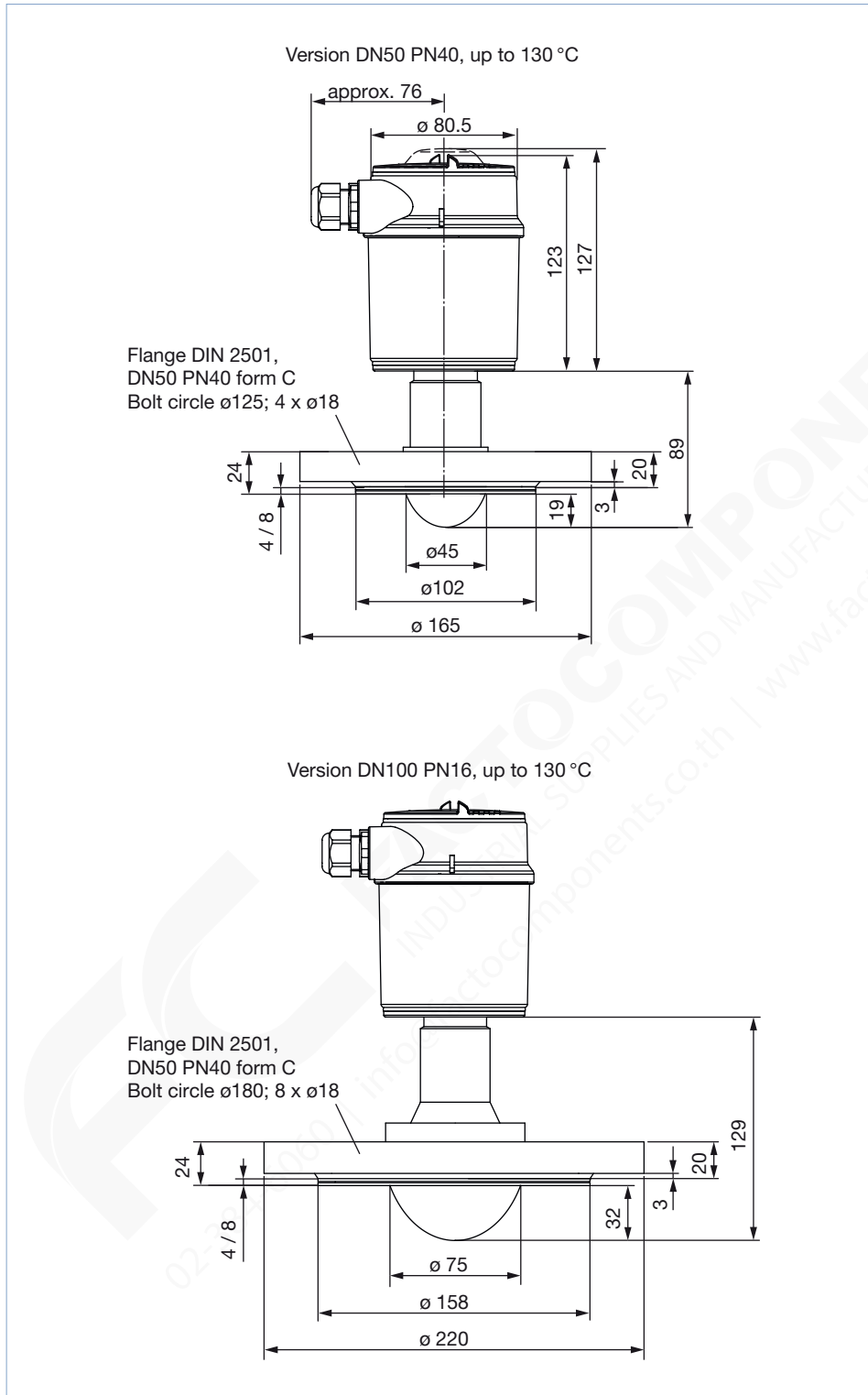

DTS 1000385105 EN Version: C Status: RL (released | freigegeben | valide) printed: 15.09.2021

5.4. Hygiene connection with encapsulated antenna system

Note:

Specifications in mm

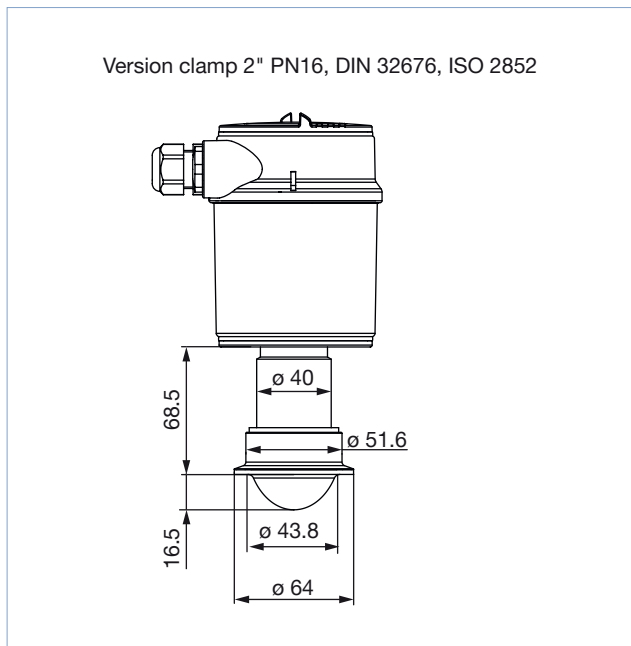

6. Performance specifications

6.1. Measurement deviation diagram

Note:

The drawing shows the measurement deviation under reference conditions of Type 8139 with thread and integrated horn antenna. This applies accordingly to all versions.

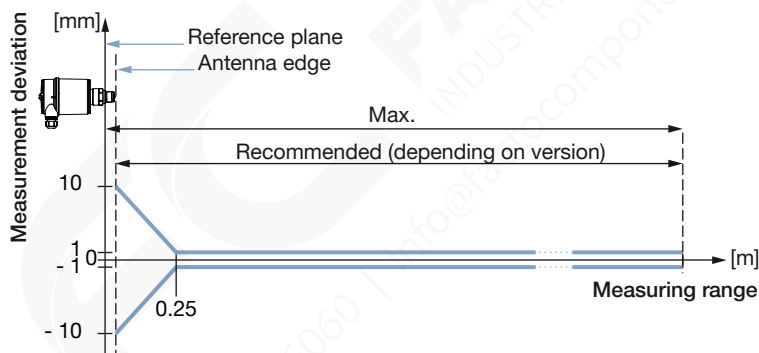

DTS 1000385105 EN Version: C Status: RL (released | freigegeben | validé) printed: 15.09.2021

6.2. Temperature derating diagram

Plastic horn antenna 80 mm

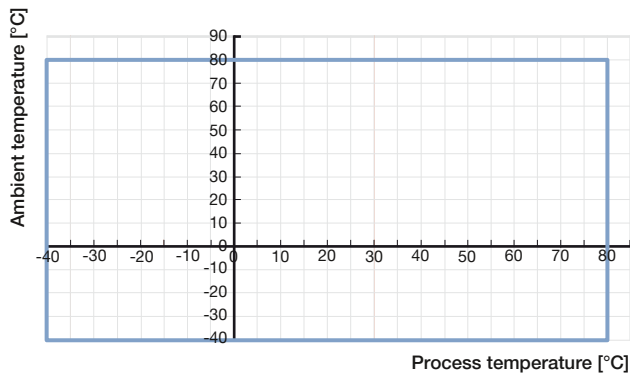

Thread with integrated antenna 40 mm

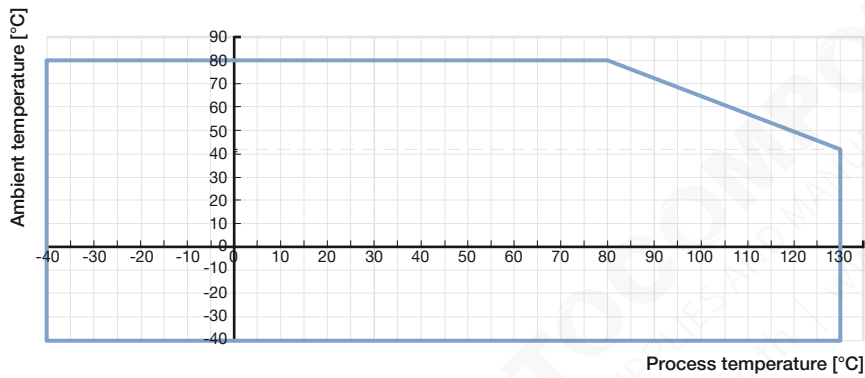

Flange with encapsulated antenna system

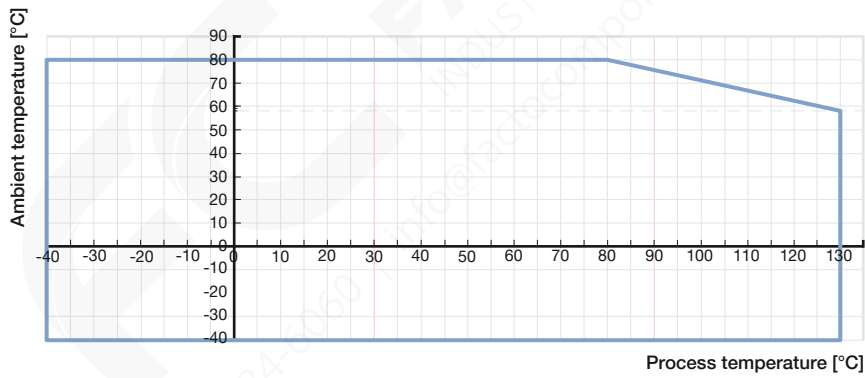

DTS 1000385105 EN Version: C Status: RL (released | freigegeben | valide) printed: 15.09.2021

7. Product installation

7.1. Mounting options

Plastic horn antenna 80 mm with mounting bracket

The mounting bracket allows simple mounting of the instrument on a wall, ceiling or boom. Especially in the case of open flumes, this is a simple and effective way to align the sensor to the surface of the liquids.

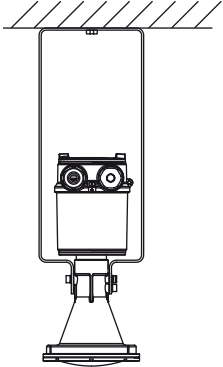
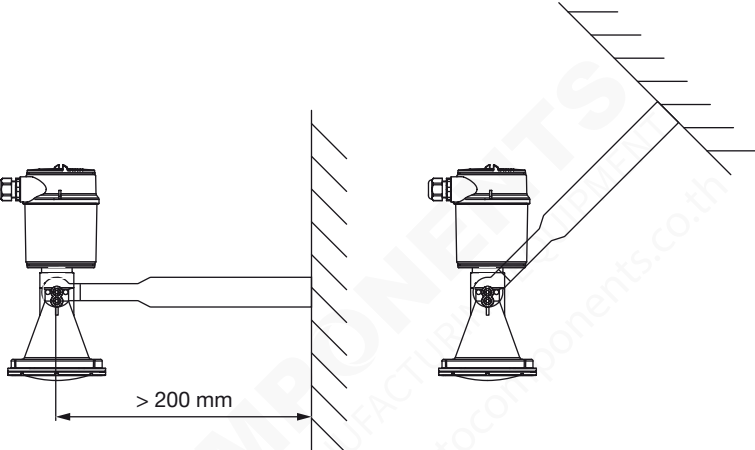
Mounting bracket - Ceiling mounting	Mounting bracket - Wall mounting
<p>The instrument is normally mounted vertically with a bracket on the ceiling. This allows the sensor to swivel up to 180° for optimal alignment and rotate for optimal connection.</p> 	<p>Alternatively, the bracket can be mounted horizontally or diagonally.</p> 

Plastic horn antenna 80 mm with flange

An adapter flange is available for mounting the device on a socket.

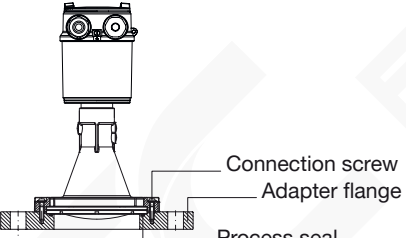
Adapter flange
<p>The adapter flange is available from DN 100. It is permanently connected with the radar sensor and sealed.</p> 

DTS 1000385105 EN Version: C Status: RL (released | freigegeben | validé) printed: 15.09.2021

8. Product operation

8.1. Measuring principle

The radar measuring device for the measurement of liquid levels consists of a housing with electronics and a process connection with antenna. The antenna of the radar sensor emits a continuous radar signal. This is reflected by the liquid surface and received by the antenna as an echo. Radar waves propagate at the speed of light. The frequency difference between the transmitted and received signal is proportional to the distance to the liquid surface. The filling level is calculated and converted into a corresponding output signal and transmitted as a measured value.

The measuring range of the radar level measuring device begins physically at the end of the antenna. However, the min./max. adjustment begins at the reference plane. The reference plane is different depending on the sensor version.

- Plastic horn antenna: the reference plane is the sealing surface on the lower edge
- Thread with integrated horn antenna: the reference plane is the sealing surface at the bottom of the hexagon
- Flange with encapsulated antenna system: the reference plane is the lower edge of the flange plating
- Hygiene connection with encapsulated antenna: the reference plane is the highest contact point between sensor process fitting and welded socket

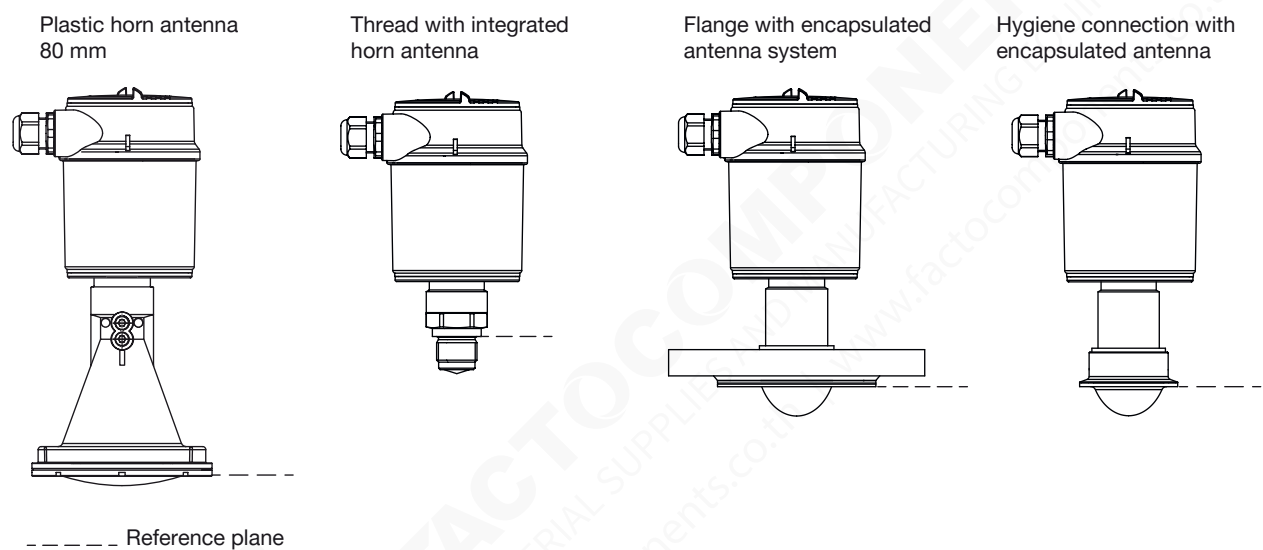

8.2. Product operation notes

Note:

The measuring device can be adjusted with:

- the display/configuration module
- the suitable Bürkert DTM in conjunction with a software according to the FDT/DTM standard, e.g. PACTware™ and PC

The entered parameters are generally saved in the measuring device Type 8139. Optionally, parameters may also be uploaded and downloaded with the display/configuration module or saved in a file by using PACTware™/8139-DTM.

Set up with display/configuration module

Display/configuration module	Description
	<p>The display/configuration module can be inserted into the measuring device and removed again at any time. It is not necessary to interrupt the power supply. The measuring device is adjusted via the four keys of the display/configuration module.</p>

Set up with PACTware™/DTM and HART communication

Assembly	Description								
	<p>The measuring device can be operated thanks to PACTware™, via HART communication. An interface adapter is necessary for the adjustment with PACTware™. For the setup of the Type 8139, the DTM in the actual version must be used. The basic version of DTM incl. PACTware™ is available as a free-of-charge download from the internet at www.burkert.com ▶.</p> <p>Connecting the PC via HART</p> <table border="1"> <thead> <tr> <th>No.</th> <th>Description</th> </tr> </thead> <tbody> <tr> <td>1</td> <td>Measuring device Type 8139</td> </tr> <tr> <td>2</td> <td>HART-USB Modem</td> </tr> <tr> <td>3</td> <td>Resistance 250 Ω</td> </tr> </tbody> </table> <p>Necessary components:</p> <ul style="list-style-type: none"> • measuring device Type 8139 • PC with PACTware™ and suitable Bürkert DTM • HART-USB Modem • resistance approx. 250 Ω • power supply unit 	No.	Description	1	Measuring device Type 8139	2	HART-USB Modem	3	Resistance 250 Ω
No.	Description								
1	Measuring device Type 8139								
2	HART-USB Modem								
3	Resistance 250 Ω								

9. Product accessories

Note:

The accessories for the plastic horn antenna 80 mm must be ordered separately.

Accessory	Description
	<p>Mounting bracket 300 mm</p>
	<p>Adapter flange DN100 PN16 FKM / PPH</p>
	<p>Adapter flange ASME (ANSI B16.5) 4" 150PSI FKM / PPH</p>

DTS 1000385105 EN Version: C Status: RL (released | freigegeben | validé) printed: 15.09.2021

10. Ordering information

10.1. Bürkert eShop – Easy ordering and quick delivery



Bürkert eShop – Easy ordering and fast delivery

You want to find your desired Bürkert product or spare part quickly and order directly? Our online shop is available for you 24/7. Sign up and enjoy all the benefits.

[Order online now](#)

10.2. Bürkert product filter

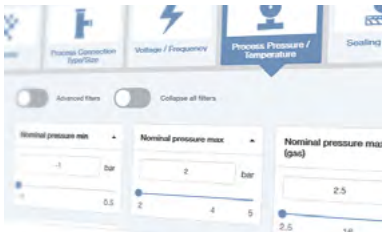

Bürkert product filter – Get quickly to the right product

You want to select products comfortably based on your technical requirements? Use the Bürkert product filter and find suitable articles for your application quickly and easily.

[Try out our product filter](#)

10.3. Ordering chart

Note:







All following versions are supplied without display/configuration module.

Description	Operating voltage	Output	Process connection	Electrical connection	Article no.
Plastic horn antenna 80 mm	12...35 V DC	4...20 mA/HART (2 wires)	Mounting bracket 170 mm	Cable gland M20 × 1.5	570592
Thread with integrated antenna 40 mm, PN20	12...35 V DC	4...20 mA/HART (2 wires)	G ¼	Cable gland M20 × 1.5	570620
			NPT ¼	Cable gland M20 × 1.5	570621
			G 1½	Cable gland M20 × 1.5	570590
			NPT 1½	Cable gland M20 × 1.5	570591
Flange with encapsulated antenna system	12...35 V DC	4...20 mA/HART (2 wires)	DN50 DIN2501, 40 bar	Cable gland M20 × 1.5	570606
			DN100 DIN2501, 16 bar	Cable gland M20 × 1.5	570607
Hygiene connection with encapsulated antenna system	12...35 V DC	4...20 mA/HART (2 wires)	Clamp 2"	Cable gland M20 × 1.5	570605

Further versions on request

Material e.g. FFKM, PFA	Pressure e.g. 1...6 bar, 1...10 bar
Process connection e.g. compression flange, adapter flange DN150, ANSI, JIS, clamp 3"	Additional With display
Temperature e.g. -40...+200 °C	Approval ATEX/IECEx-Certification

10.4. Ordering chart accessories

Description	Article no.
Set with 2 reductions M20 x 1.5/NPT½ + 2 neoprene flat seals for cable gland + 2 screw-plugs M20 x 1.5	551782 
Hart-USB Modem	560177 
Set with a display/configuration module, a transparent cover and a seal ring	559279 
Set with a transparent cover and a seal ring	561006 
Mounting bracket 300 mm	559839 
Adapter flange DN100 PN16 FKM / PPH	560437 
Adapter flange ASME (ANSI B16.5) 4" 150PSI FKM / PPH	560436 