



Radar level meter for aggressive media

- For level measurement up to 20 m
- 4...20 mA/Hart, 2 wires
- Adjustable with display/configuration module or PC
- ATEX approvals
- Insensitive to variations of temperature, pressure, medium data of the product and gas layers



Product variants described in the data sheet may differ from the product presentation and description.

Can be combined with



Type 8635

Digital electropneumatic Positioner SideControl



Type 8692

Digital electropneumatic Positioner for the integrated mounting on process control valves



Type 8644

Remote Process Actuation Control System AirLINE

Type description

Type 8136 is a non-contact radar level meter for continuous level measurement.

The unit is available in two variants:

- with encapsulated horn antenna. Particularly suitable for the level measurement of aggressive liquids in small vessels.
- with plastic horn antenna. Particularly suitable for flow measurement in open flumes or gauge measurement in waters.



Table of contents

1. General technical data	3
2. Product versions	5
2.1. Encapsulated horn antenna.....	5
2.2. Plastic horn antenna.....	5
3. Approvals	6
3.1. ATEX-Certification.....	6
4. Materials	6
4.1. Chemical Resistance Chart – Bürkert resistApp.....	6
5. Dimensions	7
5.1. Version with encapsulated horn antenna.....	7
5.2. Version with plastic horn antenna.....	7
6. Performance specifications	8
6.1. Measurement deviation diagram	8
Version with encapsulated horn antenna.....	8
Version with plastic horn antenna.....	8
7. Product installation	9
7.1. Mounting options.....	9
Version with plastic horn antenna 80 mm with mounting bracket.....	9
Version with plastic horn antenna 80 mm with flange	9
8. Product operation	10
8.1. Measuring principle	10
8.3. Product operation notes	10
Operating techniques.....	10
Set up with display/configuration module	10
Set up with PACTware™/DTM and HART communication.....	11
9. Product accessories	11
10. Ordering information	12
10.1. Bürkert eShop – Easy ordering and quick delivery.....	12
10.2. Bürkert product filter.....	12
10.3. Ordering chart.....	13
10.4. Ordering chart accessories.....	13

1. General technical data

Product properties

Material

Please make sure the device materials are compatible with the fluid you are using.

Detailed information can be found in chapter [“4.1. Chemical Resistance Chart – Bürkert resistApp” on page 6.](#)

Non wetted parts

Depending on the device version.

Detailed information can be found in chapter [“2. Product versions” on page 5.](#)

Housing	PBT, stainless steel 316L (1.4404)
Cover	PC transparent
Seal between housing and cover	EPDM
Cable gland	PA
Blind plug	PA
Ground terminal	Stainless steel 316Ti/316L (1.4571/1.4435)

Wetted parts

Depending on the device version.

Detailed information can be found in chapter [“2. Product versions” on page 5.](#)

Dimensions	Detailed information can be found in chapter “5. Dimensions” on page 7.
Weights	0.7...3.4 kg (depending on process connection and antenna)
Measuring variable	Distance between the end of the level meter antenna and the product surface. Detailed information can be found in chapters “6.1. Measurement deviation diagram” on page 8 and “8.1. Measuring principle” on page 10.
Measuring range	Max. 20 m (depending on the device version). Detailed information can be found in chapter “2. Product versions” on page 5.
Beam angle ¹⁾	Depending on the device version. Detailed information can be found in chapter “2. Product versions” on page 5.
Damping (63 % of the input value)	0...999 s, adjustable
Step response time ²⁾	≤ 3 s

Product accessories

Display LCD in full dot matrix (optional, must be ordered separately). Detailed information can be found in chapter [“10.4. Ordering chart accessories” on page 13.](#)

Performance data

Measurement deviation	± 2 mm (measuring distance > 0.5 m) Detailed information can be found in chapter “4.1. Measurement deviation diagram” on page 3.
Measuring range resolution	1 mm
Measuring frequency	K-Band (26 GHz technology)
Measuring cycle time	Approx. 450 ms
Temperature drift	<ul style="list-style-type: none"> Digital output: ± 3 mm/10 K, max. 10 mm Current output: < 0.03 %/10K relating to the 16 mA span or ≤ 0.3 %
Non-repeatability ³⁾	≤ 1 mm
Vibration resistance	Depending on the device version. Detailed information can be found in chapter “2. Product versions” on page 5.
Shock resistance	100 g, 6 ms according to EN 60068-2-27 (mechanical shock)

Electrical data

Operating voltage (U _n)	<ul style="list-style-type: none"> Without display/configuration module: <ul style="list-style-type: none"> – 9.6...35 V DC – 9.6...30 V DC (Ex ia instrument) With display/configuration module: <ul style="list-style-type: none"> – 16...35 V DC – 16...30 V DC (Ex ia instrument)
Power Source (not supplied)	Limited power source according to UL/EN 60950-1 standards or limited energy circuit according to UL/EN 61010-1 §9.4
Starting current	≤ 3.6 mA; ≤ 10 mA for 5 ms after switching on
DC reverse polarity protection	Yes
Output signal	4...20 mA/HART
Signal resolution	0.3 µA

Range of the output signal	3.8...20.5 mA/HART (default setting)
Load resistor	$(U_n - U_{min.})/0.022 \text{ A}$
Fault signal	Current output: mA value unchanged, 20.5 mA, 22 mA or <3.6 mA (adjustable)
Max. output current	22 mA
Residual ripple (for DC)	<ul style="list-style-type: none"> For $9.6 \text{ V} < U_n < 18 \text{ V}$: $\leq 0.7 V_{eff}$ (16...400 Hz) For $18 \text{ V} < U_n < 35 \text{ V}$: $\leq 1.0 V_{eff}$ (16...400 Hz)
Voltage supply cable	<ul style="list-style-type: none"> Cable diameter: 5...9 mm Wire cross-section (spring-loaded terminals): <ul style="list-style-type: none"> massive wire, stranded wire: 0.2...2.5 mm² (AWG 24...14) stranded wire with end sleeve: 0.2...1.5 mm² (AWG 24...16)

Medium data

Process temperature	-40 °C...+80 °C (-40 °F...+176 °F)
Process pressure	Depending on the device version. Detailed information can be found in chapter "2. Product versions" on page 5.
Dielectric constant (min.)	$\epsilon_r > 1.6$

Process/Port connection & communication

Process connection	Depending on the device version. Detailed information can be found in chapter "2. Product versions" on page 5.
Electrical connection	Cable glands M20 x 1.5

Approvals and Certificates**Standards**

Degree of protection according to IEC/EN 60529	IP66/IP67 with M20 x 1.5 gland mounted and tightened
Overvoltage category according to IEC 61010-1	Category III
Protection class according to IEC 61010-1	Class III

Directives

CE directives	The applied standards, which verify conformity with the EU Directives, can be found on the EU Type Examination Certificate and/or the EU Declaration of conformity (if applicable)
NAMUR recommendations	<ul style="list-style-type: none"> NE21 – Electromagnetic compatibility of equipment NE43 – Signal level for fault information from measuring transducers NE53 – Compatibility of field devices and display/adjustment components NE107 – Self-monitoring and diagnosis of field devices

Approvals

ATEX	EN 60079-0, EN 60079-11, EN 60079-26 Detailed information can be found in chapter "3.1. Certification ATEX" on page 6.
------	---

Environment and installation

Ambient temperature	Operation and storage: -40 °C...+80 °C (-40 °F...+176 °F)
Relative air humidity	20...85 %, without condensation
Height above sea level	<ul style="list-style-type: none"> By default: max. 2000 m With connected overvoltage protection: max. 5000 m
Pollution degree	Degree 4 (when used with fulfilled housing protection)

- 1.) Outside the specified beam angle, the energy level of the radar signal is 50 % (-3 dB) less
- 2.) Time span after a sudden measuring distance change by max. 0.5 m in liquid applications, max 2 m with bulk solids applications, until the output signal has taken for the first time 90 % of the final value (IEC 61298-2)
- 3.) Already included in the measuring deviation

2. Product versions

2.1. Encapsulated horn antenna

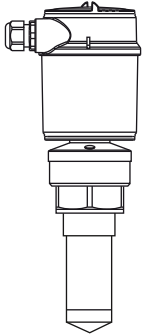

Product details	
Material	Wetted parts: <ul style="list-style-type: none"> • Process connection made of PVDF • Antenna made of PVDF (completely encapsulated) • Seal made of FKM
Beam angle ^{1.)}	22°
Measuring range	0.05...10 m
Vibration resistance	4 g with 5...200 Hz according to EN 60068-2-6 (vibration at resonance)
Process connection	Thread G 1½" or NPT 1½"
Process pressure	Vessel pressure: -1...3 bar (-100...300 kPa/-14.5...43.5 psi)

1.) Outside the specified beam angle, the energy level of the radar signal is 50% (-3 dB) less

2.2. Plastic horn antenna

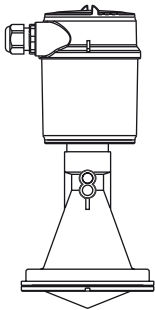

Product details	
Material	Non wetted parts: <ul style="list-style-type: none"> • Mounting strap made of stainless steel 316L (1.4435) • Fixing screws made of stainless steel 316L (1.4435) Wetted parts: <ul style="list-style-type: none"> • Antenna made of PBT-GF30 • Focus lens made of PP
Beam angle ^{1.)}	10°
Measuring range	0...20 m
Vibration resistance	<ul style="list-style-type: none"> • With mounting strap: 1 g with 5...200 Hz according to EN 60068-2-6 (vibration at resonance) • With adapter flange (in option): 2 g with 5...200 Hz according to EN 60068-2-6 (vibration at resonance)
Process connection	Mounting bracket 170 mm
Process pressure	Vessel pressure: <ul style="list-style-type: none"> • -1...2 bar (-100...200 kPa/-14.5...29.0 psi) • Version with adapter flange from DN 100: -1...1 bar (-100...100 kPa/-14.5...14.5 psi)
Accessories	
Material	Non wetted parts: <ul style="list-style-type: none"> • Adapter flange fixing screw made of stainless steel 304 Wetted parts: <ul style="list-style-type: none"> • Adapter flange made of PP-GF30 black • Sealing of the adaptor flange made of FKM (COG VI500)

1.) Outside the specified beam angle, the energy level of the radar signal is 50% (-3 dB) less

3. Approvals

3.1. Certification ATEX

Note:

Devices with Ex certification have different technical data, see **Supplement ATEX Type 8136** ▶ under user manual.

Certificate	Description
	<p>EU-Type Examination Certificate Number: PTB 08 ATEX 2002X</p> <p>ATEX</p> <ul style="list-style-type: none"> • II 1/2G Ex ia IIC T6 Ga/Gb • II 2G Ex ia IIC T6 Gb <p>Measures to comply with ATEX requirements: refer to the Supplement ATEX Type 8136 ▶ under user manual. The Ex. certification is only valid if the Bürkert device is used as described in the supplement ATEX. If unauthorized changes are made to the device, the Ex. certification becomes invalid.</p>

4. Materials

4.1. Chemical Resistance Chart – Bürkert resistApp

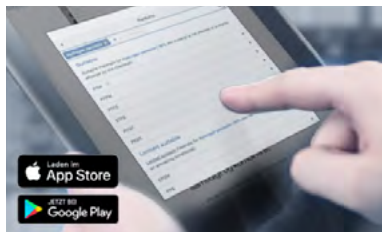

Bürkert resistApp – Chemical Resistance Chart

You want to ensure the reliability and durability of the materials in your individual application case? Verify your combination of media and materials on our website or in our resistApp.

[Start Chemical Resistance Check](#)

5. Dimensions

5.1. Version with encapsulated horn antenna

Note:

Dimensions in mm

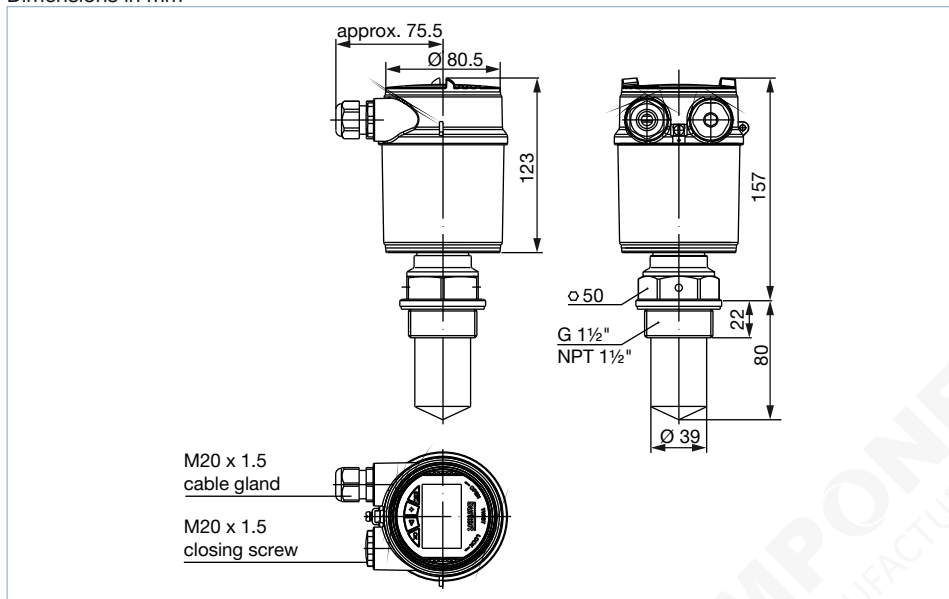

5.2. Version with plastic horn antenna

Note:

Dimensions in mm

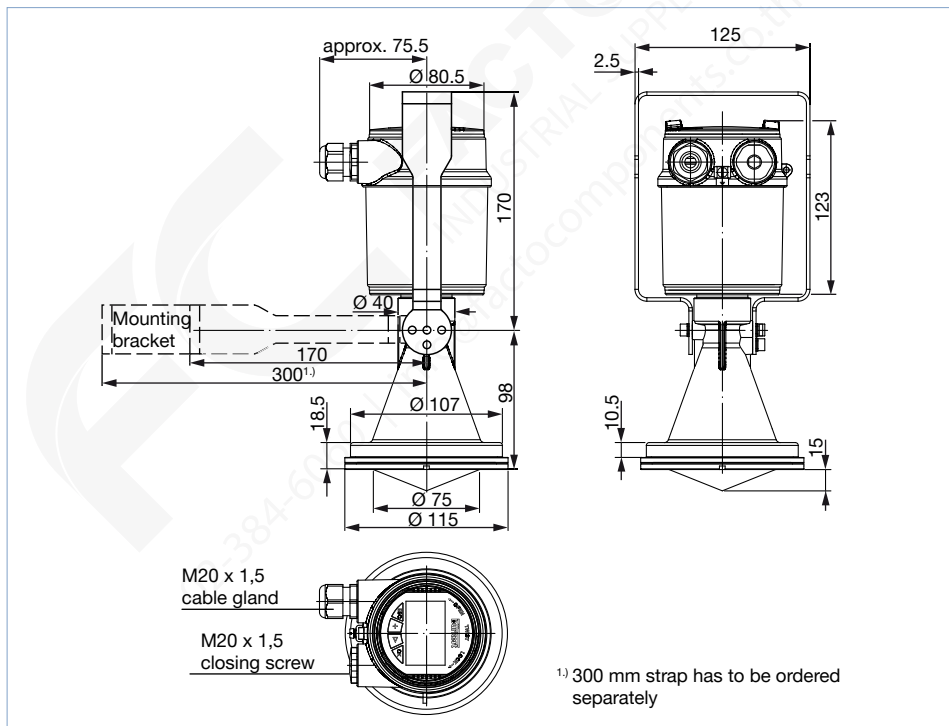

¹⁾ 300 mm strap has to be ordered separately

DTS 1000105436 EN Version: L Status: RL (released | freigegeben | valide) printed: 15.09.2021

6. Performance specifications

6.1. Measurement deviation diagram

Version with encapsulated horn antenna

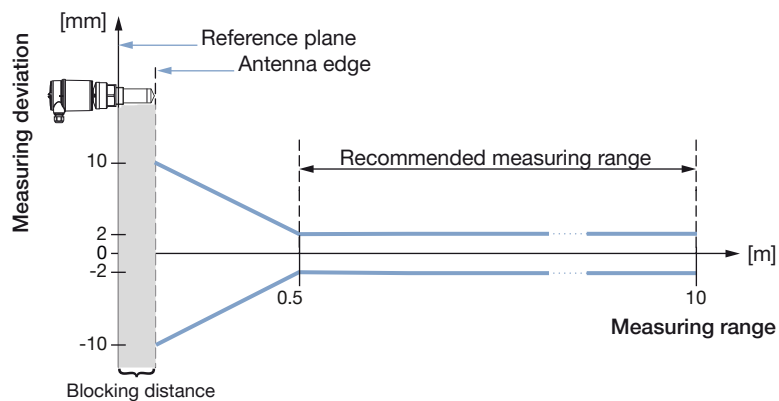

Version with plastic horn antenna

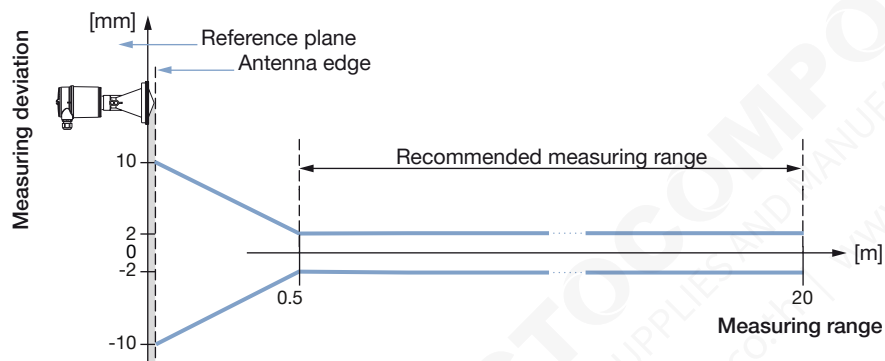

DTS 1000105436 EN Version: L Status: RL (released | freigegeben | validé) printed: 15.09.2021

7. Product installation

7.1. Mounting options

Version with plastic horn antenna 80 mm with mounting bracket

The mounting bracket allows simple mounting of the instrument on a wall, ceiling or boom. Especially in the case of open flumes, this is a simple and effective way to align the sensor to the surface of the liquids.

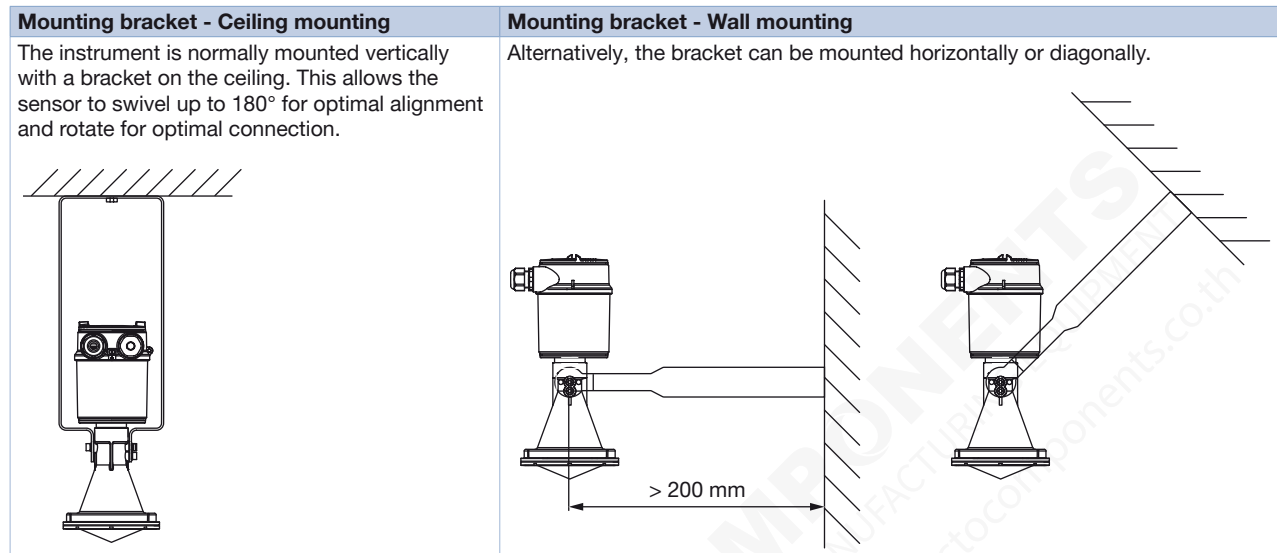

Version with plastic horn antenna 80 mm with flange

An adapter flange is available for mounting the device on a socket.

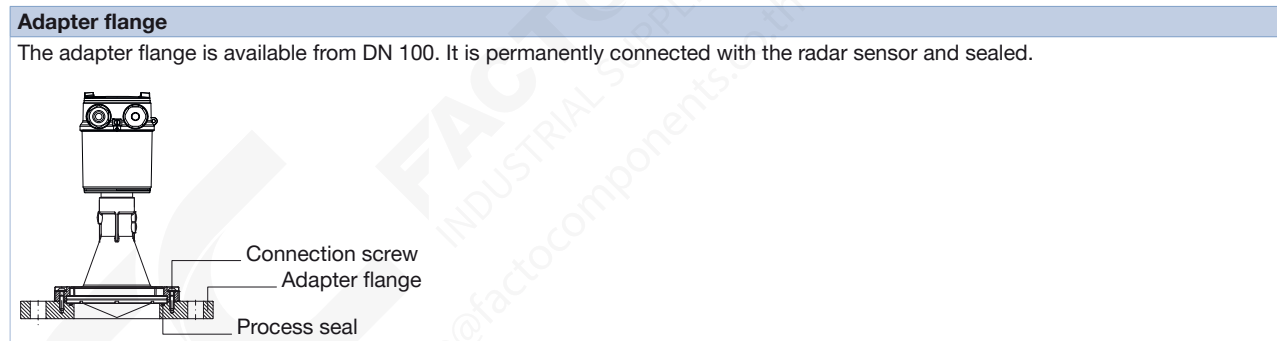

8. Product operation

8.1. Measuring principle

The radar measuring device consists of an electronic housing, a process connection element with antenna and a sensor. The antenna emits short radar pulses with a duration of approximate 1 ns to the medium. These pulses are reflected by the medium surface and received by the antenna as echoes. Radar waves travel at the speed of light. The running time of the radar pulses from emission to reception is proportional to the distance and hence to the level. The determined level is converted into an output signal and transmitted as a measured value.

The measuring range of the radar level measuring device begins physically at the end of the antenna. However, the min./max. adjustment begins at the reference plane. The position of the reference plane depends on the sensor version.

- Version with encapsulated horn antenna: the reference plane is the sealing surface on the hexagon.
- Version with plastic horn antenna: the reference plane is the lower side of the flange.

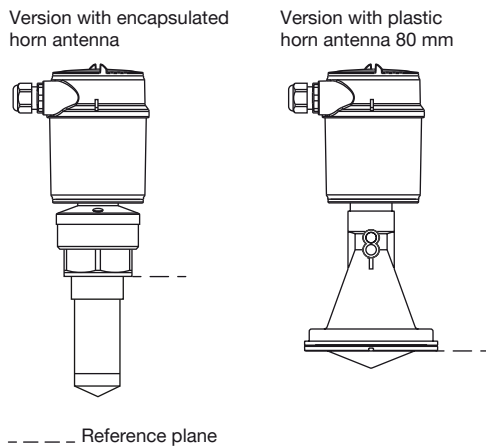

8.2.

8.3. Product operation notes

Operating techniques

The measuring device provides different operating techniques:

- the display/configuration module
- the suitable Bürkert DTM in conjunction with adjustment software according to the FDT/DTM standard, e.g. PACTware™ and PC
- a HART handheld

The entered parameters are generally saved in the measuring device Type 8136. Optionally, parameters may also be uploaded and downloaded with the display/configuration module or saved in a file by using PACTware™/8136-DTM.

Set up with display/configuration module

Display/configuration module	Description
	<p>The display/configuration module can be inserted into the measuring device and removed again at any time. It is not necessary to interrupt the power supply. The measuring device is adjusted via the four keys of the display/configuration module.</p>

Set up with PACTware™/DTM and HART communication

Assembly	Description								
	<p>The measuring device can be operated thanks to PACTware™, via HART communication. An interface adapter is necessary for the adjustment with PACTware™. For the setup of the Type 8136, the DTM in the actual version must be used. The basic version of DTM incl. PACTware™ is available as a free-of-charge download from the internet at www.burkert.com ▶.</p> <p>Connecting the PC via HART</p> <table border="1"> <thead> <tr> <th style="background-color: #d9e1f2;">No.</th> <th style="background-color: #d9e1f2;">Description</th> </tr> </thead> <tbody> <tr> <td>1</td> <td>Measuring device Type 8136</td> </tr> <tr> <td>2</td> <td>HART-USB Modem</td> </tr> <tr> <td>3</td> <td>Resistance 250 Ω</td> </tr> </tbody> </table> <p>Necessary components:</p> <ul style="list-style-type: none"> • Measuring device Type 8136 • PC with PACTware™ and suitable Bürkert DTM • HART-USB Modem • Resistance approx. 250 Ω • Power supply unit 	No.	Description	1	Measuring device Type 8136	2	HART-USB Modem	3	Resistance 250 Ω
No.	Description								
1	Measuring device Type 8136								
2	HART-USB Modem								
3	Resistance 250 Ω								

9. Product accessories

Note:

The accessories for the plastic horn antenna 80 mm must be ordered separately.

Accessory	Description
	<p>Mounting bracket 300 mm</p>

Accessory	Description
	Adapter flange DN 100 PN 16 FKM / PP-GF30
	Adapter flange ASME (ANSI B16.5) 4" 150PSI FKM / PP-GF30

10. Ordering information

10.1. Bürkert eShop – Easy ordering and quick delivery



Bürkert eShop – Easy ordering and fast delivery

You want to find your desired Bürkert product or spare part quickly and order directly? Our online shop is available for you 24/7. Sign up and enjoy all the benefits.

[Order online now](#)

10.2. Bürkert product filter

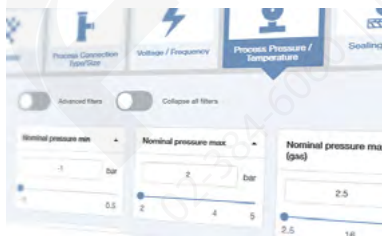

Bürkert product filter – Get quickly to the right product

You want to select products comfortably based on your technical requirements? Use the Bürkert product filter and find suitable articles for your application quickly and easily.

[Try out our product filter](#)

10.3. Ordering chart

Note:

All following versions are supplied without display/configuration module.

Operating voltage	Output	Antenna version	Process connection	Electrical connection	Article no.
Standard version					
9.6...35 V DC	4...20 mA/HART (2 wires)	Encapsulated horn antenna, 40 mm	G 1½"	Cable gland M20x1.5	560146
			NPT 1½"		560148
		Plastic horn antenna, 80 mm	Mounting bracket		560150
Ex version – ATEX approval					
9.6...30 V DC	4...20 mA/HART (2 wires)	Encapsulated horn antenna, 40 mm	G 1½"	Cable gland M20x1.5	560147
			NPT 1½"		560149
		Plastic horn antenna, 80 mm	Mounting bracket		560151

Further versions on request

Process connection

- Clamp 2", 3"
- Slotted nut DN 50, DN 80 PN 3, DIN 11851 / 316L,
- Compression flange suitable for flanges DN 80 PN 16, ANSI 3", JIS DN 80 10K / PP-GF30
- Adapter flange:
 - DN 150 PN 16 FKM / PP-GF30
 - ANSI 4" 150PSI FKM / PP-GF30
 - ANSI 6" 150PSI FKM / PP-GF30
 - JIS DN 100 10K FKM / PP-GF30
 - JIS DN 150 10K FKM / PP-GF30

10.4. Ordering chart accessories

Description	Article no.
Set with 2 reductions M20x1.5/NPT½" + 2 neoprene flat seals for cable gland + 2 screw-plugs M20x1.5	551782
Hart-USB Modem	560177
Set with a display/configuration module, a transparent cover and a seal ring	559279
Set with a transparent cover and a seal ring	561006
Mounting bracket 300 mm	559839
Adapter flange DN 100 PN 16 FKM / PP-GF30	560437
Adapter flange ASME (ANSI B16.5) 4" 150PSI FKM / PP-GF30	560436