





Servo-assisted 2/2-way piston valve

- Servo-assisted piston valve up to DN 50 orifice
- Safe opening with hard-coupled piston system without differential pressure
- Vibration-resistant, push-over coil system
- Explosion-proof versions
- Energy-saving double coil technology with kick and drop design

Product variants described in the data sheet may differ from the product presentation and description.

Can be combined with

	Type 2518 Cable plug, form A according to DIN EN 175301 - 803	▶
	Type 1087 Timer, form A according to DIN EN 175301 - 803	▶
	Type 2509 Cable plug, form A according to DIN EN 175301 - 803	▶

Type description

The Type 6407 valve is a servo-assisted piston valve. The fix coupling between pilot valve and piston provides an opening of the valve without pressure difference. As a piston valve, the Type 6407 is particular suitable for media such as gas and steam. As well as liquids with low operating temperature below 0 °C. The stopper and the core guide pipe are welded together to enhance pressure resistance and leak-tightness. Various seal material combinations are available depending on the application. The coils are moulded with chemically resistant epoxy. To reduce power consumption in operation, coils with "Kick and Drop" (KD) electronics (double coil technology) are available. In combination with a plug acc. to DIN EN 175301 - 803 Form A, the valves satisfy IP65 degree of protection.



Table of contents

1. General technical data	3
2. Circuit functions	4
3. Approvals and conformities	4
3.1. General notes.....	4
3.2. Conformity.....	4
3.3. Standards.....	4
3.4. Explosion protection.....	4
3.5. North America (USA/Canada).....	5
4. Materials	5
4.1. Bürkert resistApp.....	5
4.2. Material specifications.....	5
Threaded body.....	5
Flange body.....	6
5. Dimensions	7
5.1. Standard version DN 13...DN 32.....	7
Threaded version.....	7
Flange version.....	8
5.2. Standard version DN 50.....	9
Threaded version.....	9
Flange version.....	10
5.3. ATEX/IECEx version.....	11
6. Performance specifications	12
6.1. Power consumption.....	12
7. Product accessories	12
7.1. Special tool to turn the terminal box.....	12
8. Ordering information	12
8.1. Bürkert eShop.....	12
8.2. Bürkert product filter.....	12
8.3. Bürkert Product Enquiry Form.....	13
8.4. Ordering chart standard version DN 13...DN 32.....	13
UL Recognized with coil UL Recognized (cURus).....	13
UL Listed with coil UL Recognized (cULus).....	13
8.5. Ordering chart steam version with valve seat in stainless steel DN 13...DN 32.....	14
UL Recognized with coil UL Recognized (cURus).....	14
UL Listed with coil UL Recognized (cULus).....	14
8.6. Ordering chart steam version with flange connection DN 25 and DN 32.....	15
Coil UL recognized (cURus).....	15
8.7. Ordering chart standard version DN 50.....	15
Steam version with valve seat in stainless steel DN 50.....	16
8.8. Ordering chart explosion proof version DN 13...DN 25.....	16
Coil UL Listed (cULus) for hazardous locations, Class 1, Division 2 cable version.....	16
Coil UL Listed (cULus) for hazardous locations, Class 1, Division 2 terminal box version.....	16
8.9. Ordering chart accessories.....	17
Cable plug Type 2518, form A according to DIN EN 175301 - 803.....	17
Cable plug Type 2509, form A according to DIN EN 175301 - 803.....	17
Special tool to turn the terminal box.....	18

DTS 1000583397 EN Version: A Status: RL (released | freigegeben | validé) printed: 15.01.2024

1. General technical data

Product properties	
Dimensions	Further information can be found in chapter "5. Dimensions" on page 7.
Material	
Seal	PTFE/graphite
Body	Brass
Coil	Epoxy
Orifice	DN 13...DN 50
Circuit function	A
	Further information can be found in chapter "2. Circuit functions" on page 4.
Thermal insulation class of solenoid coil	Epoxy coil class H
Performance data	
Duty cycle	100 % continuous operation, Kick and Drop coil max. 6 switching cycles/minute
Switching time¹⁾	
DN 13	Opening: 30 ms Closing: 250 ms
DN 20	Opening: 30 ms Closing: 250 ms
DN 25	Opening: 60 ms Closing: 700 ms
DN 32	Opening: 80 ms Closing: 900 ms
DN 50	Opening: 500 ms Closing: 2000 ms
Electrical data	
Operating voltage	24 V/DC, 24 V/50 Hz, 24 V/60 Hz, 110 V/50 Hz, 120 V/60 Hz, 230 V/50 Hz, 240 V/60 Hz (further voltages on request)
Power consumption	Further information can be found in chapter "6.1. Power consumption" on page 12.
Voltage tolerance	± 10 %
Medium data	
Operating medium	Neutral gases and liquids (e.g. compressed air, water, hydraulic oil, hot water and steam)
Medium temperature	
Standard version	PTFE + graphite: -40 °F...+302 °F PTFE + FKM: +14 °F...+248 °F
Steam version	PTFE + graphite: +32 °F...+302 °F PTFE + FKM: +32 °F...+248 °F
ATEX/IECEX version	Max. +194 °F
Viscosity	Max. 21 cSt
Process/Port connection & communication	
Electrical connection	<ul style="list-style-type: none"> Plug contacts according to DIN EN 175 301 -803 form A for cable plug Type 2518 ▶ Further information can be found in chapter "Cable plug Type 2518, form A according to DIN EN 175301 -803" on page 17. Plug contacts according to DIN EN 175 301 -803 form A for cable plug Type 2509 ▶ Further information can be found in chapter "Cable plug Type 2509, form A according to DIN EN 175301 -803" on page 17.
Port connection	G ½, G ¾, G 1, G 1 ¼, G 1 ½, G 2, G 2 ½ NPT ½, NPT ¾, NPT 1, NPT 1 ¼, NPT 1 ½, NPT 2
Approvals and conformities	
Degree of protection	IP65 with cable plug
Explosion protection	Further information can be found in chapter "3.4. Explosion protection" on page 4.
North America (USA/Canada)	Further information can be found in chapter "3.5. North America (USA/Canada)" on page 5.
Environment and installation	
Installation position	As required, preferably with actuator upright
Ambient temperature	
Standard version	PTFE + graphite: -40 °F...+131 °F PTFE + FKM: +14 °F...+131 °F
Steam version	PTFE + graphite: +32 °F...+113 °F (+131 °F on request) PTFE + FKM: +32 °F...+131 °F
ATEX/IECEX version	14 °F...+104 °F

1.) Measurement at +68 °F, 87 psi at the valve outlet, opening: pressure build-up 0...90 %, closing: pressure reduction 100...10 %

2. Circuit functions

Symbol	Description
	Circuit function A (CF A) 2/2-way solenoid valve Servo-controlled Normally closed

3. Approvals and conformities

3.1. General notes

- The approvals and conformities listed below must be stated when making enquiries. This is the only way to ensure that the product complies with all required specifications.
- Not all available versions can be supplied with the below mentioned approvals or conformities.

3.2. Conformity

In accordance with the Declaration of Conformity, the product is compliant with the EU Directives.

3.3. Standards

The applied standards which are used to demonstrate compliance with the EU Directives are listed in the EU-Type Examination Certificate and/or the EU Declaration of Conformity.

3.4. Explosion protection

Approval	Description								
 	Optional: Explosion protection according to category 2 (zone 1/21) Ex marking of the components according to the following table:								
	<table border="1"> <thead> <tr> <th colspan="2">Coil Type AC19</th> </tr> <tr> <th>Coil with cable outlet</th> <th>Coil with terminal box</th> </tr> </thead> <tbody> <tr> <td> ATEX: EPS 16 ATEX 1072 X II 2G Ex mb IIC T4 Gb II 2D Ex mb IIIC T130 °C Db </td> <td> ATEX: EPS 16 ATEX 1072 X II 2G Ex eb mb IIC T4 Gb II 2D Ex mb tb IIIC T130 °C Db </td> </tr> <tr> <td> IECEX: IECEX EPS 16.0030 X II 2G Ex mb IIC T4 Gb II 2D Ex mb IIIC T130 °C Db </td> <td> IECEX: IECEX EPS 16.0030 X II 2G Ex eb mb IIC T4 Gb II 2D Ex mb tb IIIC T130 °C Db </td> </tr> </tbody> </table>	Coil Type AC19		Coil with cable outlet	Coil with terminal box	ATEX: EPS 16 ATEX 1072 X II 2G Ex mb IIC T4 Gb II 2D Ex mb IIIC T130 °C Db	ATEX: EPS 16 ATEX 1072 X II 2G Ex eb mb IIC T4 Gb II 2D Ex mb tb IIIC T130 °C Db	IECEX: IECEX EPS 16.0030 X II 2G Ex mb IIC T4 Gb II 2D Ex mb IIIC T130 °C Db	IECEX: IECEX EPS 16.0030 X II 2G Ex eb mb IIC T4 Gb II 2D Ex mb tb IIIC T130 °C Db
	Coil Type AC19								
Coil with cable outlet	Coil with terminal box								
ATEX: EPS 16 ATEX 1072 X II 2G Ex mb IIC T4 Gb II 2D Ex mb IIIC T130 °C Db	ATEX: EPS 16 ATEX 1072 X II 2G Ex eb mb IIC T4 Gb II 2D Ex mb tb IIIC T130 °C Db								
IECEX: IECEX EPS 16.0030 X II 2G Ex mb IIC T4 Gb II 2D Ex mb IIIC T130 °C Db	IECEX: IECEX EPS 16.0030 X II 2G Ex eb mb IIC T4 Gb II 2D Ex mb tb IIIC T130 °C Db								
Optional: Explosion protection according to category 3 (zone 2/22) Ex marking of the components according to the following table:									
	<table border="1"> <thead> <tr> <th>Coil Type AC19</th> </tr> <tr> <th>Coil with plug contacts form A and cable plug Type 2509</th> </tr> </thead> <tbody> <tr> <td> ATEX: EPS 16 ATEX 1072 X II 2G Ex mb IIC T4 Gb II 2D Ex mb IIIC T130 °C Db </td> </tr> <tr> <td> IECEX: IECEX EPS 16.0030 X II 2G Ex mb IIC T4 Gb II 2D Ex mb IIIC T130 °C Db </td> </tr> </tbody> </table>	Coil Type AC19	Coil with plug contacts form A and cable plug Type 2509	ATEX: EPS 16 ATEX 1072 X II 2G Ex mb IIC T4 Gb II 2D Ex mb IIIC T130 °C Db	IECEX: IECEX EPS 16.0030 X II 2G Ex mb IIC T4 Gb II 2D Ex mb IIIC T130 °C Db				
Coil Type AC19									
Coil with plug contacts form A and cable plug Type 2509									
ATEX: EPS 16 ATEX 1072 X II 2G Ex mb IIC T4 Gb II 2D Ex mb IIIC T130 °C Db									
IECEX: IECEX EPS 16.0030 X II 2G Ex mb IIC T4 Gb II 2D Ex mb IIIC T130 °C Db									

DTS 1000583397 EN Version: A Status: RL (released | freigegeben | validé) printed: 15.01.2024

3.5. North America (USA/Canada)

Approval	Description
	Optional: UL Listed for the USA (valid for valves) The valves are UL Listed for the USA according to: <ul style="list-style-type: none"> UL 429 (electrically operated valves)
	Optional: UL Hazardous Locations – Explosion Protection (valid for coils) UL Listed for Hazardous Locations for USA and Canada Class I, Zone 1 Class I, Division 2, Group A, B, C and D Class II + III, Division 2, Group F and G
	Optional: UL Recognized for the USA (valid for valves) The valves are UL Recognized for the USA according to: <ul style="list-style-type: none"> UL 429 (electrically operated valves)

4. Materials

4.1. Bürkert resistApp

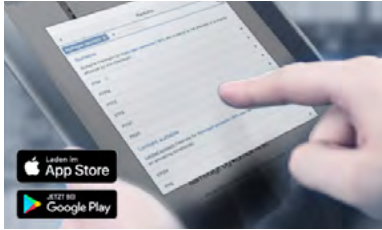

Bürkert resistApp – Chemical resistance chart

You want to ensure the reliability and durability of the materials in your individual application case? Verify your combination of media and materials on our website or in our resistApp.

[Start chemical resistance check](#)

4.2. Material specifications

Threaded body

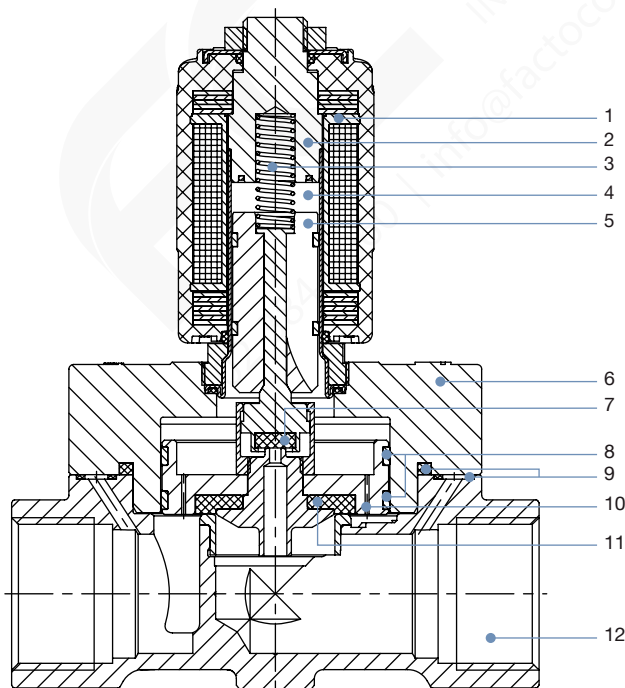

No.	Element	Material
1	Coil	Epoxy
2	Stopper	Stainless steel 1.4113/434 ^{1.)}
3	Spring	Stainless steel 1.4310/301 ^{1.)}
4	Armature guide tube	Stainless steel 1.4303/305 ^{1.)} /308 ^{1.)}
5	Core	Stainless steel 1.4113/434 ^{1.)}
6	Cover	Brass
7	Seal	PTFE
8	Piston rings	PTFE
9	Sealing rings	Graphite
10	Plunger	Brass
11	Piston seal	PTFE
12	Body	Brass

1.) Material designation according to AISI

Flange body

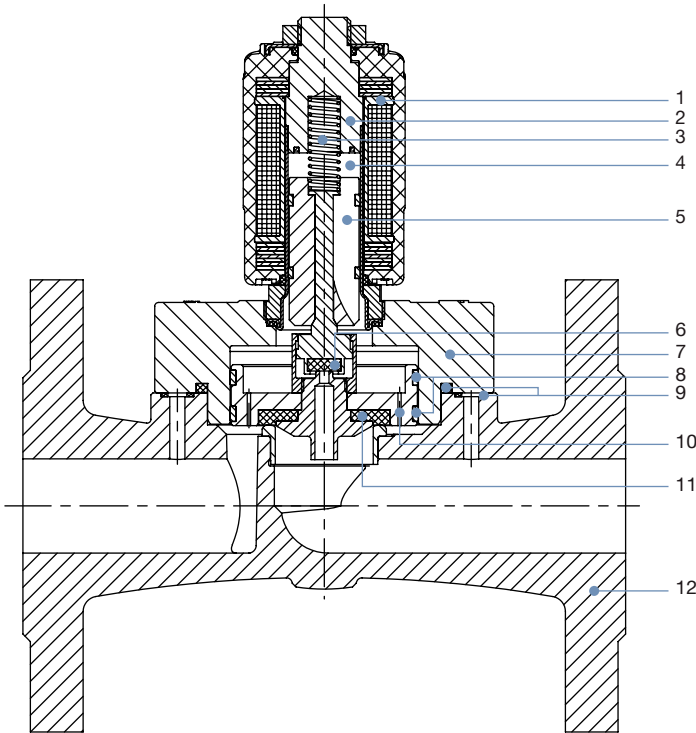

No.	Element	Material
1	Coil	Epoxy
2	Stopper	Stainless steel 1.4113/434 ^{1.)}
3	Spring	Stainless steel 1.4310/301 ^{1.)}
4	Armature guide tube	Stainless steel 1.4303/305 ^{1.)} /308 ^{1.)}
5	Core	Stainless steel 1.4113/434 ^{1.)}
6	Seal	PTFE
7	Cover	Brass
8	Piston rings	PTFE
9	Sealing rings	Graphite
10	Plunger	Brass
11	Piston seal	PTFE
12	Body	Stainless steel 1.4581/similar 316Ti ^{1.)}

1.) Material designation according to AISI

DTS 1000583397 EN Version: A Status: RL (released | freigegeben | validé) printed: 15.01.2024

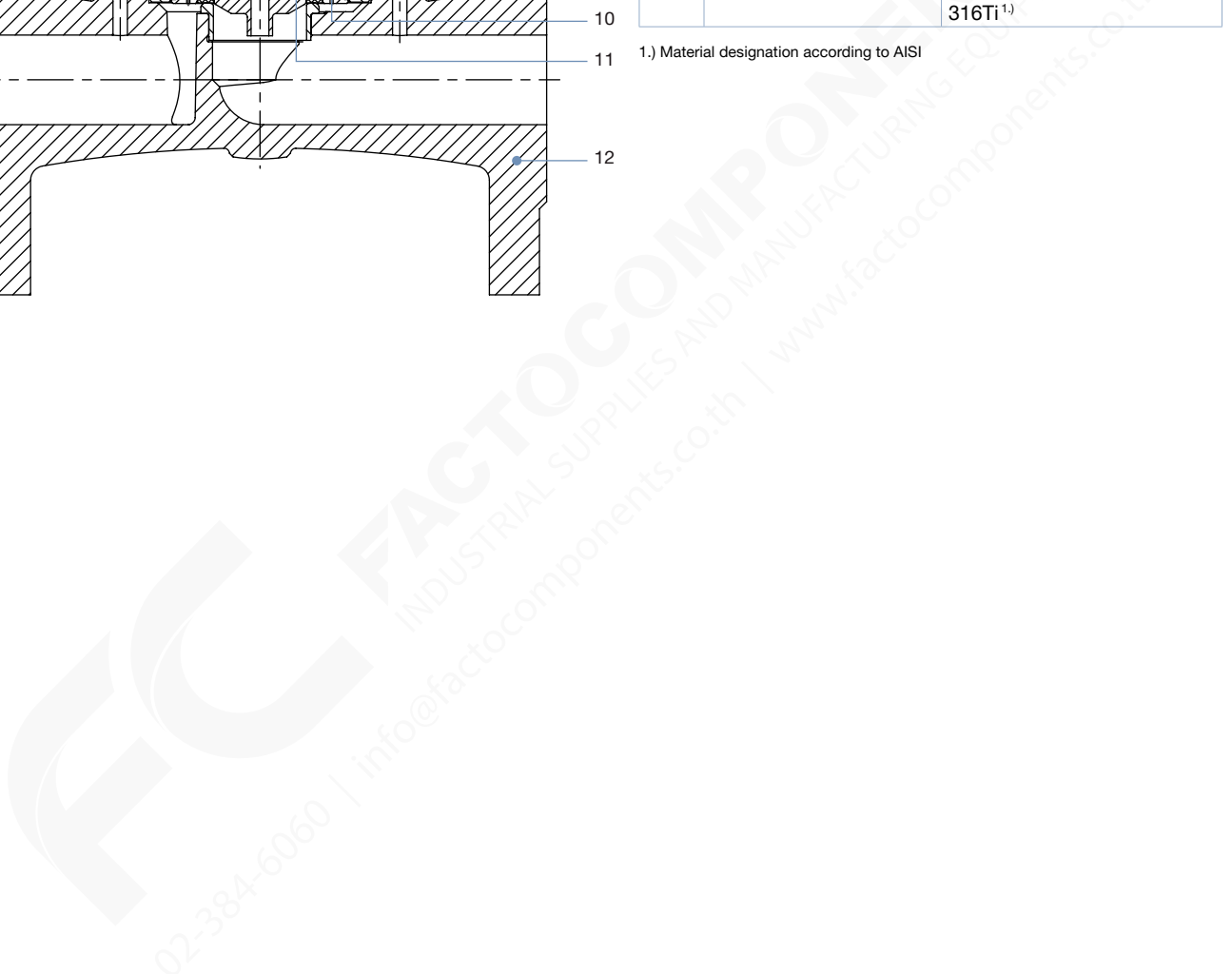

5. Dimensions

5.1. Standard version DN 13...DN 32

Threaded version

Note:

- Dimensions in mm [inch]
- The dimensions D1 and F1 apply to G-threads.
- The dimensions D2 and F2 apply to NPT-threads.
- The dimensions D3 and F3 apply to Rc-threads.

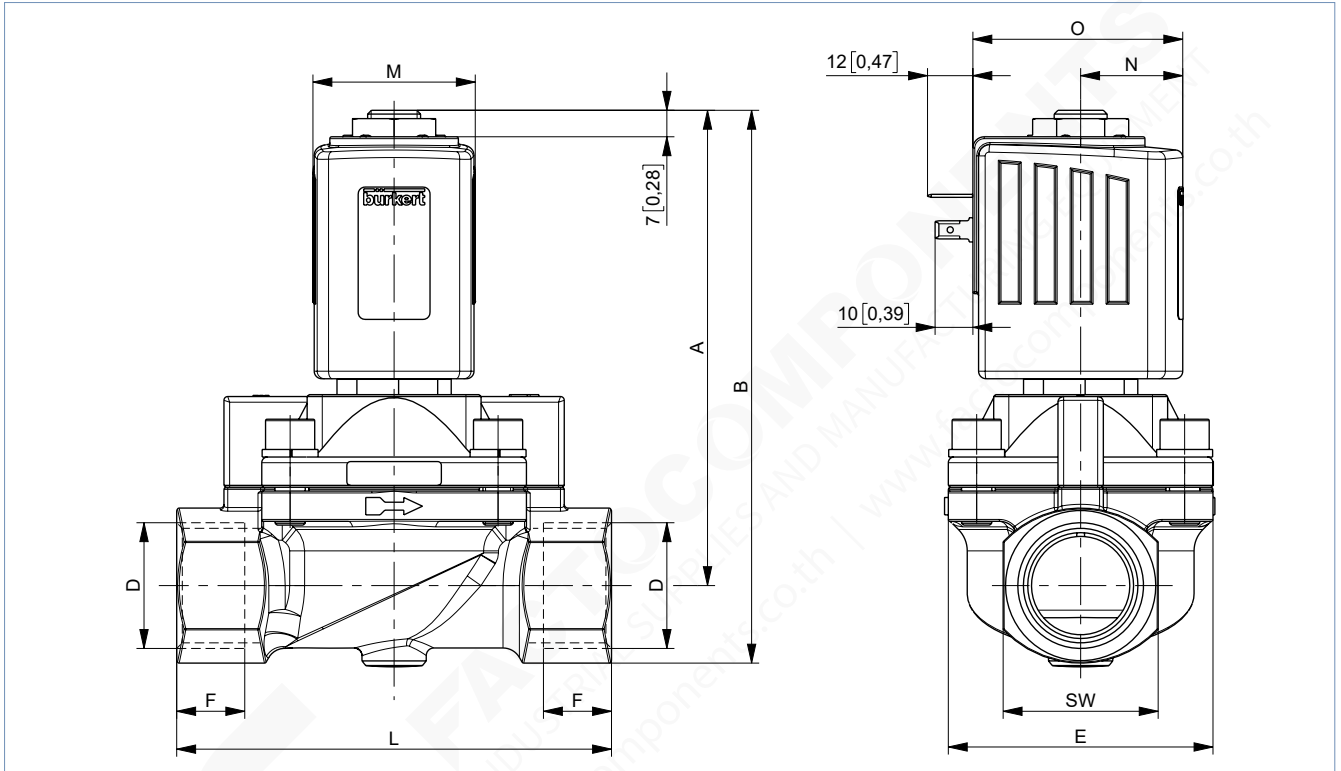

Coil size	M		N		O	
	[mm]	[in]	[mm]	[in]	[mm]	[in]
K	42	1.65	27	1.06	55.5	2.19
L	65	2.56	37.5	1.48	72	2.83

DN	A		B		G thread			NPT thread			Rc thread			E		L		SW	
	[mm]	[in]	[mm]	[in]	D1	F1		D2	F2		D3	F3		[mm]	[in]	[mm]	[in]	[mm]	[in]
					[Zoll]	[mm]	[in]	[Zoll]	[mm]	[in]	[Zoll]	[mm]	[in]						
13	118.7	4.67	132.7	5.22	-	-	-	-	-	-	Rc 3/8	10.1	-	40	1.57	65	2.56	27	1.06
13					G 1/2	14	0.55	NPT 1/2	13.7	0.54	Rc 1/2	13.2	-						
20	119.7	4.71	135.7	5.34	G 3/4	16	0.63	NPT 3/4	14	0.55	Rc 3/4	14.5	0.57	60	2.36	100	3.94	32	1.26
25	125.7	4.95	146.2	5.76	G 1	18	0.71	NPT 1	16.8	0.66	Rc 1	16.8	0.66	70	2.76	115	4.53	41	1.61
32	142.7	5.62	167.7	6.60	G 1 1/4	20	0.79	NPT 1 1/4	17.3	0.68	Rc 1 1/4	19.1	0.75	85	3.35	126	4.96	50	1.97
32	146.7	5.78	176.7	6.96	G 1 1/2	22	0.87	NPT 1 1/2	17.3	0.68	Rc 1 1/2	19.1	0.75	85	3.35	126	4.96	60	2.36

DTS 1000583397 EN Version: A Status: RL (released | freigegeben | validé) printed: 15.01.2024

Flange version

Note:

Dimensions in mm [inch]

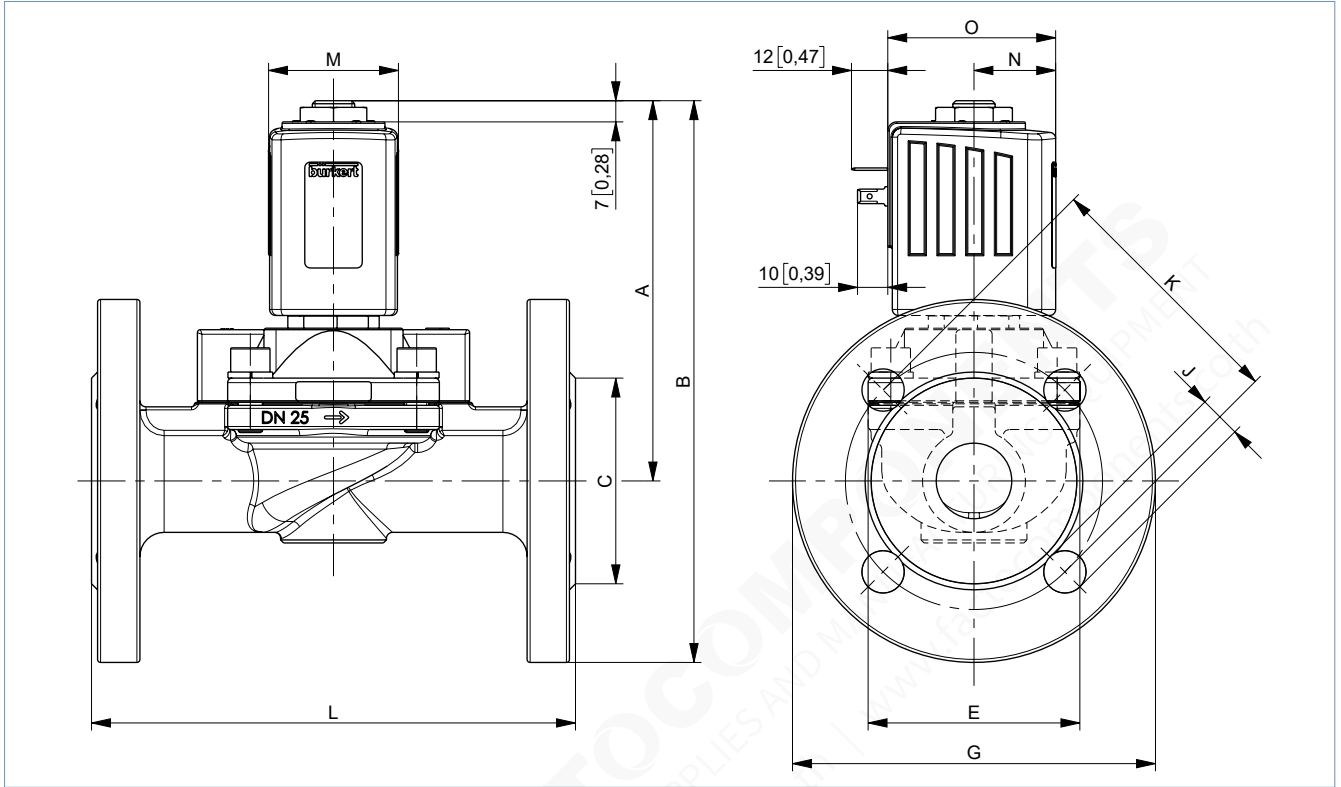

Coil size	M		N		O	
	[mm]	[in]	[mm]	[in]	[mm]	[in]
K	42	1.65	27	1.06	55.5	2.19
L	65	2.56	37.5	1.48	72	2.83

DN	A		B		C		E		G		L		J		K	
	[mm]	[in]	[mm]	[in]	[mm]	[in]	[mm]	[in]	[mm]	[in]	[mm]	[in]	[mm]	[in]	[mm]	[in]
25	129.7	5.11	189.7	7.47	68	2.68	73	2.87	120	4.72	160	6.30	14	0.55	85	3.35
32	142.7	5.62	212.7	8.37	78	3.07	85	3.35	140	5.51	180	7.09	18	0.71	100	3.94
32	146.7	5.78	221.7	8.73	88	3.46	85	3.35	150	5.91	200	7.87	18	0.71	110	4.33

DTS 1000583397 EN Version: A Status: RL (released | freigegeben | validé) printed: 15.01.2024

5.2. Standard version DN 50

Threaded version

Note:

- Dimensions in mm [inch]
- The dimensions D1 and F1 apply to G-threads.
- The dimensions D2 and F2 apply to NPT-threads.
- The dimensions D3 and F3 apply to Rc-threads.

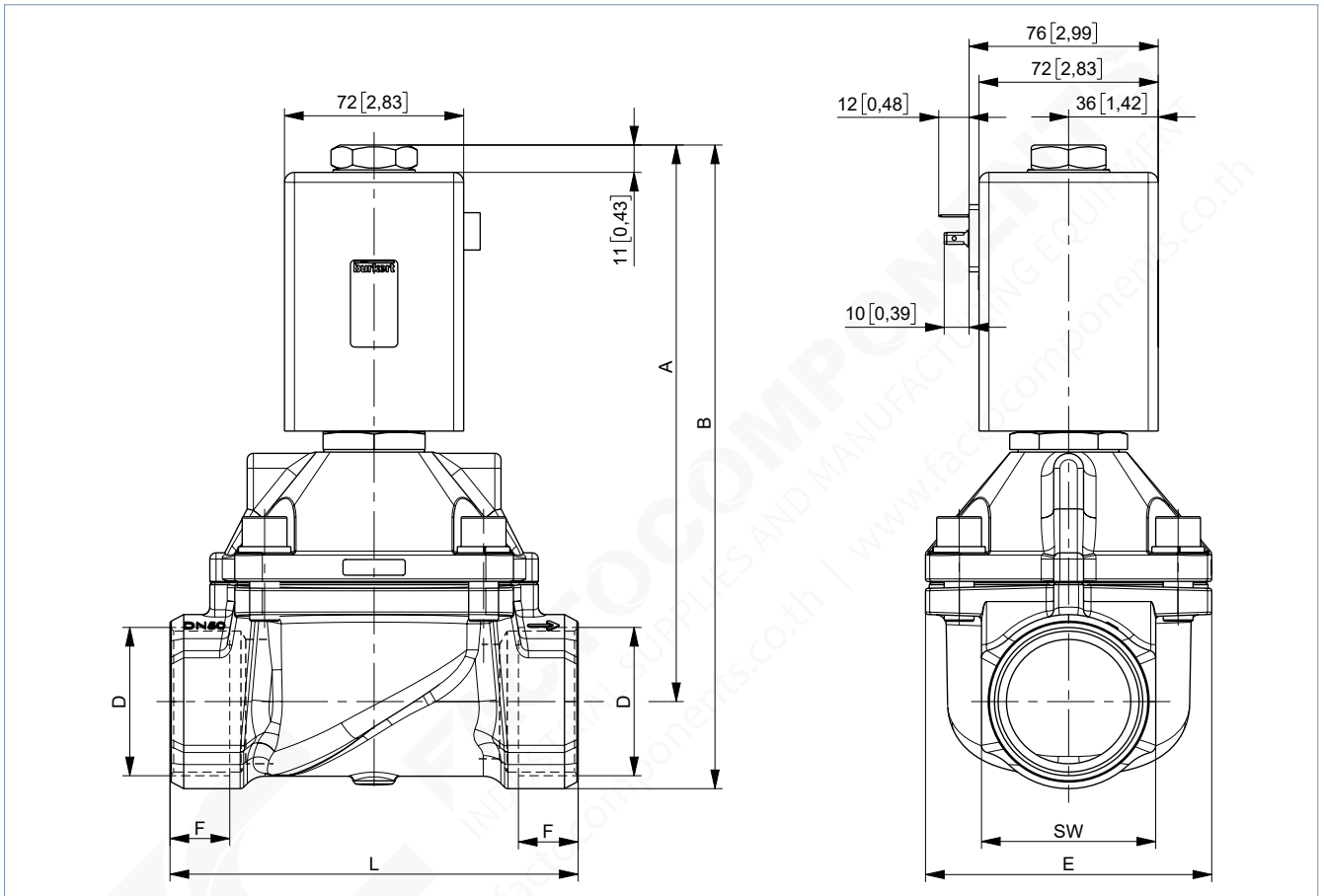

DN	A		B		G thread			NPT thread			Rc thread			E		L		SW	
	[mm]	[in]	[mm]	[in]	D1 [Zoll]	F1 [mm]	[in]	D2 [Zoll]	F2 [mm]	[in]	D3 [Zoll]	F3 [mm]	[in]	[mm]	[in]	[mm]	[in]	[mm]	[in]
50	223.9	8.81	258.9	10.19	G 2	24	0.94	NPT 2	17.6	0.69	Rc 2	23.4	0.92	115	4.53	164	6.46	70	2.76
50	223.6	8.80	266.1	10.48	G 2½	27	1.06	NPT 2½	23.6	0.93	-	-	-	115	4.53	179	7.05	85	3.35

DTS 1000583397 EN Version: A Status: RL (released | freigegeben | validé) printed: 15.01.2024

Flange version

Note:

- Dimensions in mm [inch]
- The dimensions D1 and F1 apply to G-threads.
- The dimensions D2 and F2 apply to NPT-threads.
- The dimensions D3 and F3 apply to Rc-threads.

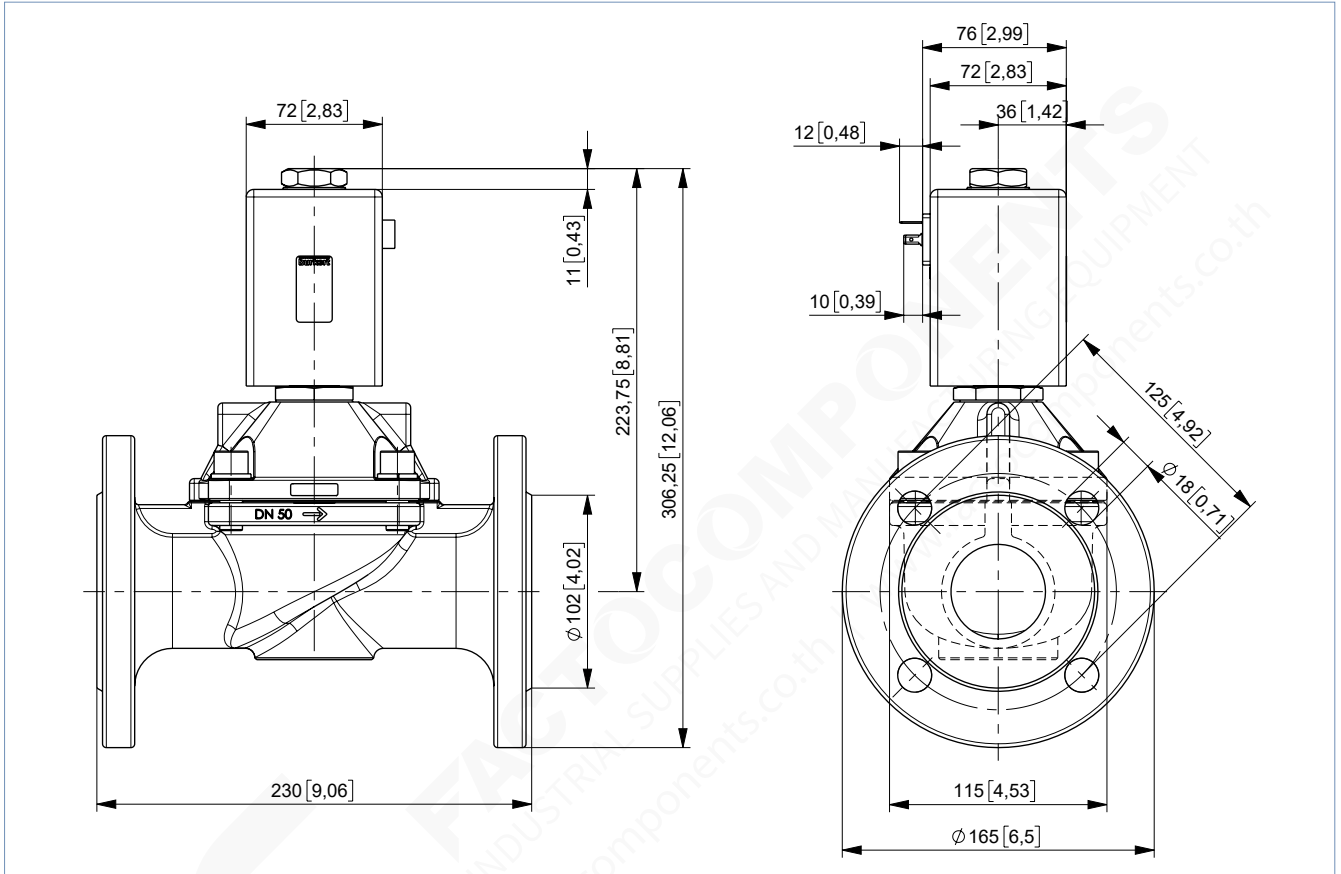

DTS 1000583397 EN Version: A Status: RL (released | freigegeben | validé) printed: 15.01.2024

5.3. ATEX/IECEX version

Note:

- Dimensions in mm [inch]
- The dimensions D1 and F1 apply to G-threads.
- The dimensions D2 and F2 apply to NPT-threads.
- The dimensions D3 and F3 apply to Rc-threads.

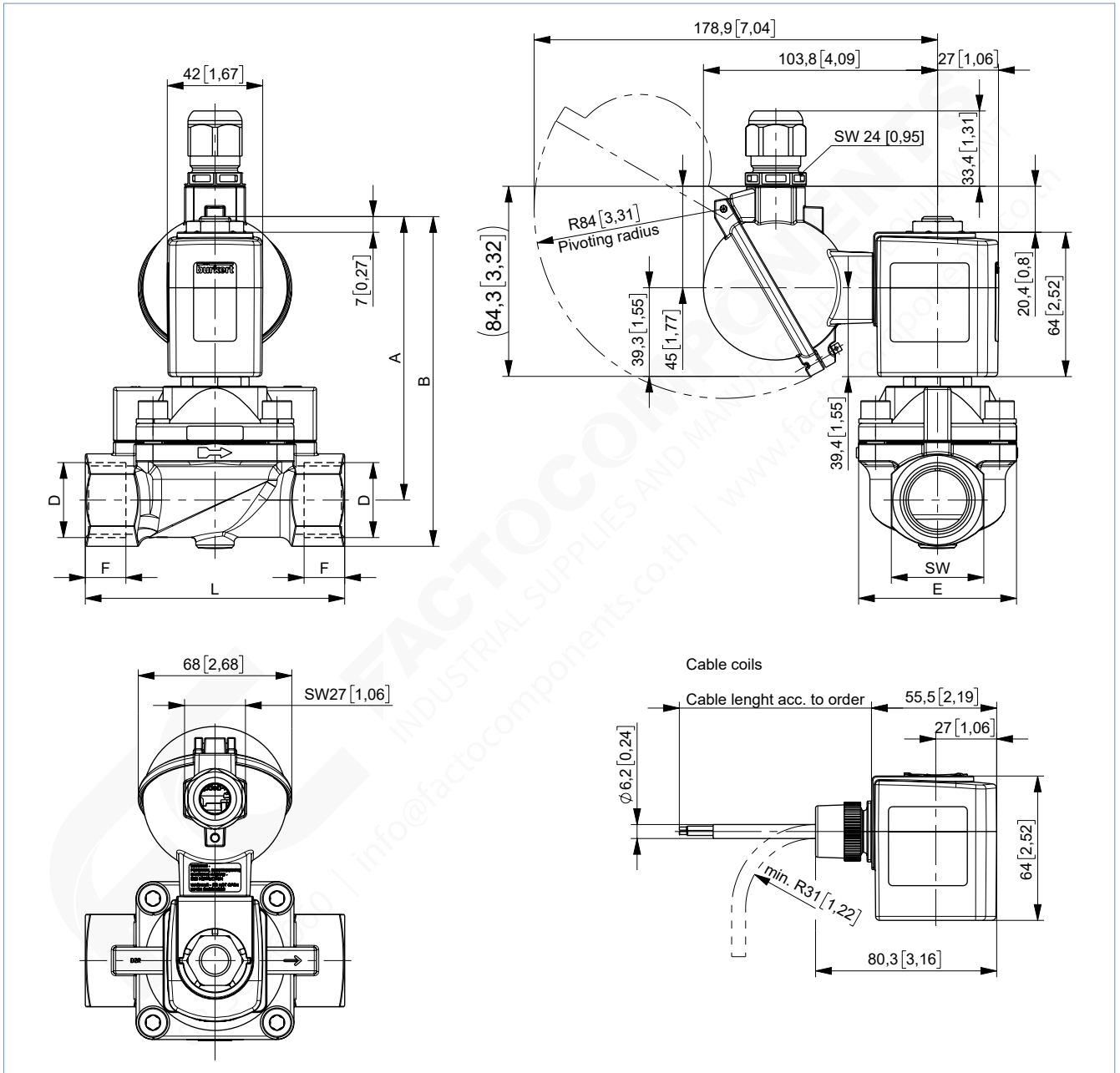

DN	A		B		G thread		NPT thread			Rc thread			E		L		SW		
	[mm]	[in]	[mm]	[in]	D1	F1	D2	F2	D3	F3	[mm]	[in]	[mm]	[in]	[mm]	[in]	[mm]	[in]	
					[Zoll]	[mm] [in]	[Zoll]	[mm] [in]	[Zoll]	[mm] [in]	[mm] [in]								
13	118.7	4.67	132.7	5.22	-	-	-	-	Rc 3/8	10.1	0.40	40	1.57	65	2.56	27	1.06		
13					G 1/2	14	0.55	NPT 1/2	13.7	0.54	Rc 1/2	13.2	0.52						
20	119.7	4.71	135.7	5.34	G 3/4	16	0.63	NPT 3/4	14	0.55	Rc 3/4	14.5	0.57	60	2.36	100	3.94	32	1.26
25	125.7	4.95	146.2	5.76	G 1	18	0.71	NPT 1	16.8	0.66	Rc 1	16.8	0.66	70	2.76	115	4.53	41	1.61

DTS 1000583397 EN Version: A Status: RL (released | freigegeben | validé) printed: 15.01.2024

6. Performance specifications

6.1. Power consumption

Note:

The Kick and Drop coil (AC/DC) features integrated electronics for short-term power increase and decrease in double coil technology.

Orifice	Coil size	AC			DC		Kick and Drop coil (AC/DC)			AC with external rectifier
		Inrush power	Holding power		Cold performance	Warm performance	Cold performance Inrush power	Cold performance Holding power	Warm performance Holding power	Nominal power
[mm]	[mm]	[VA]	[VA]	[W]	[W]	[W]	[W] 500 ms	[W]	[W]	[W]
13	42	140	41	16	21	16	85	8.5	7	-
13 ATEX	42	-	-	-	15	12	-	-	-	-
20	42	150	41	16	-	-	85	8.5	7	-
25	42	160	41	16	-	-	85	8.5	7	-
32	42	170	41	16	-	-	85	8.5	7	-
20...25 ATEX	42	-	-	-	-	-	44	6.5	5.5	-
20...32	65	-	-	-	28	21	-	-	-	-
50	72	-	-	-	39	30	-	-	-	45

7. Product accessories

7.1. Special tool to turn the terminal box

Note:

Detailed ordering information can be found in chapter **“Special tool to turn the terminal box”** on page 18.

8. Ordering information

8.1. Bürkert eShop



Bürkert eShop – Easy ordering and quick delivery

You want to find your desired Bürkert product or spare part quickly and order directly? Our online shop is available for you 24/7. Sign up and enjoy all the benefits.

[Order online now](#)

8.2. Bürkert product filter



Bürkert product filter – Get quickly to the right product

You want to select products comfortably based on your technical requirements? Use the Bürkert product filter and find suitable articles for your application quickly and easily.

[Try out our product filter](#)

DTS 1000583397 EN Version: A Status: RL (released | freigegeben | validé) printed: 15.01.2024

8.3. Bürkert Product Enquiry Form

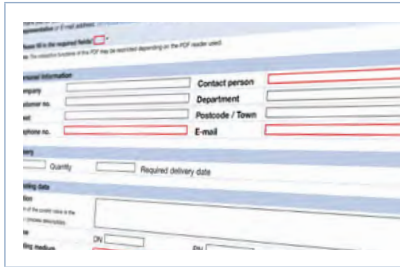

Bürkert Product Enquiry Form – Your enquiry quickly and compactly

Would you like to make a specific product enquiry based on your technical requirements? Use our Product Enquiry Form for this purpose. There you will find all the relevant information for your Bürkert contact. This will enable us to provide you with the best possible advice.

[Fill out the form now](#)

8.4. Ordering chart standard version DN 13...DN 32

UL Recognized with coil UL Recognized (cURus)

Note:

Please note that the cable plug **Type 2518** is included. Further versions are available on request. For more information on the cable plug, see **“Cable plug Type 2518, form A according to DIN EN 175301 - 803” on page 17.**

Circuit function	Port connection	Orifice [mm]	C _v value water [gal/min]	Pressure range (MAWP ^{1.)} [psi]	Max. medium temperature [°F]	Coil size [inch]	Article no.				
							024/DC [V/Hz]	024/50...60 or DC [V/Hz]	110...120/50...60 [V/Hz]	230...240/50...60 [V/Hz]	
Brass body, seal material PTFE/graphite											
CF A 2/2-way solenoid valve Servo-controlled Normally closed 	NPT 1/2	13	4.28	0...145	302	1.65	348888	348883	348893	348898	
	NPT 3/4	20	6.47	0...145	302	1.65	–	348884	348894	348900	
							2.56	348889	–	–	–
	NPT 1	25	11.56	0...145	302	1.65	–	348885	348895	348901	
							2.56	348890	–	–	–
	NPT 1 1/4	32	18.50	0...145	302	1.65	–	348886	348896	348902	
							2.56	348891	–	–	–
	NPT 1 1/2	32	18.50	0...145	302	1.65	–	348887	348897	348903	
							2.56	348892	–	–	–

– = not available

1.) Maximum allowable working pressure

UL Listed with coil UL Recognized (cULus)

Note:

Please note that the cable plug **Type 2509** is included. Further versions are available on request. For more information on the cable plug, see **“Cable plug Type 2509, form A according to DIN EN 175301 - 803” on page 17.**

Circuit function	Port connection	Orifice [mm]	C _v value water [gal/min]	Pressure range (MAWP ^{1.)} [psi]	Max. medium temperature [°F]	Coil size [inch]	Article no.				
							024/DC [V/Hz]	024/50...60 or DC [V/Hz]	110...120/50...60 [V/Hz]	230...240/50...60 [V/Hz]	
Brass body, seal material PTFE/graphite											
CF A 2/2-way solenoid valve Servo-controlled Normally closed 	NPT 1/2	13	4.28	0...145	302	1.65	o. r.	o. r.	o. r.	o. r.	
	NPT 3/4	20	6.47	0...145	302	1.65	–	o. r.	o. r.	o. r.	
							2.56	o. r.	–	–	–
	NPT 1	25	11.56	0...145	302	1.65	–	o. r.	o. r.	o. r.	
							2.56	o. r.	–	–	–
	NPT 1 1/4	32	18.50	0...145	302	1.65	–	o. r.	o. r.	o. r.	
							2.56	o. r.	–	–	–
	NPT 1 1/2	32	18.50	0...145	302	1.65	–	o. r.	o. r.	o. r.	
							2.56	o. r.	–	–	–

– = not available

o. r. = on request

1.) Maximum allowable working pressure

DTS 1000583397 EN Version: A Status: RL (released | freigegeben | validé) printed: 15.01.2024

8.5. Ordering chart steam version with valve seat in stainless steel DN 13...DN 32

UL Recognized with coil UL Recognized (cURus)

Note:

- Please note that the cable plug **Type 2518** ▶ is included. Further versions are available on request. For more information on the cable plug, see “**Cable plug Type 2518, form A according to DIN EN 175301 - 803**” on page 17.
- Due to the temperature range, the cable plug with silicone seal is provided for steam versions.

Circuit function	Port connection	Orifice	C _v value water	Pressure range (MAWP ^{1.)})	Max. medium temperature	Coil size	Article no.			
							024/DC	024/50...60 or DC	110...120/50...60	230...240/50...60
							[V/Hz]	[V/Hz]	[V/Hz]	[V/Hz]
Brass body, seal material PTFE/graphite										
CF A 2/2-way solenoid valve Servo-controlled Normally closed 	NPT ½	13	4.28	0...145	302	1.65	348867 𐀀	348862 𐀀	348872 𐀀	348878 𐀀
	NPT ¾	20	6.47	0...145	302	1.65	-	348863 𐀀	348874 𐀀	348879 𐀀
						2.56	348868 𐀀	-	-	-
	NPT 1	25	11.56	0...145	302	1.65	-	348864 𐀀	348875 𐀀	348880 𐀀
						2.56	348869 𐀀	-	-	-
	NPT 1¼	32	18.50	0...145	302	1.65	-	348865 𐀀	348876 𐀀	348881 𐀀
						2.56	348870 𐀀	-	-	-
	NPT 1½	32	18.50	0...145	302	1.65	-	348866 𐀀	348877 𐀀	348882 𐀀
						2.56	348871 𐀀	-	-	-

- = not available
 1.) Maximum allowable working pressure

UL Listed with coil UL Recognized (cULus)

Note:

- Please note that the cable plug **Type 2509** ▶ is included. Further versions are available on request. For more information on the cable plug, see “**Cable plug Type 2509, form A according to DIN EN 175301 - 803**” on page 17.
- Due to the temperature range, the cable plug with silicone seal is provided for steam versions.

Circuit function	Port connection	Orifice	C _v value water	Pressure range (MAWP ^{1.)})	Max. medium temperature	Coil size	Article no.			
							024/DC	024/50...60 or DC	110...120/50...60	230...240/50...60
							[V/Hz]	[V/Hz]	[V/Hz]	[V/Hz]
Brass body, seal material PTFE/graphite										
CF A 2/2-way solenoid valve Servo-controlled Normally closed 	NPT ½	13	4.28	0...145	302	1.65	o. r.	o. r.	o. r.	o. r.
	NPT ¾	20	6.47	0...145	302	1.65	-	o. r.	o. r.	o. r.
						2.56	o. r.	-	-	-
	NPT 1	25	11.56	0...145	302	1.65	-	o. r.	o. r.	o. r.
						2.56	o. r.	-	-	-
	NPT 1¼	32	18.50	0...145	302	1.65	-	o. r.	o. r.	o. r.
						2.56	o. r.	-	-	-
	NPT 1½	32	18.50	0...145	302	1.65	-	o. r.	o. r.	o. r.
						2.56	o. r.	-	-	-

o. r. = on request
 - = not available
 1.) Maximum allowable working pressure

DTS 1000583397 EN Version: A Status: RL (released | freigegeben | validé) printed: 15.01.2024

8.6. Ordering chart steam version with flange connection DN 25 and DN 32

Coil UL recognized (cURus)

Note:

- Please note that the cable plug **Type 2518** ▶ is included. Further versions are available on request. For more information on the cable plug, see **“Cable plug Type 2518, form A according to DIN EN 175301 - 803” on page 17.**
- Due to the temperature range, the cable plug with silicone seal is provided for steam versions.

Circuit function	Port connection	Orifice [mm]	C _v value water [gal/min]	Pressure range (MAWP ^{1.)} [psi]	Max. medium temperature [°F]	Coil size [inch]	Article no.			
							024/DC	024/50...60 or DC	110...120/ 50...60	230...240/ 50...60
							[V/Hz]	[V/Hz]	[V/Hz]	[V/Hz]
Stainless steel/brass body, seal material PTFE/graphite										
CF A 2/2-way solenoid valve Servo-controlled Normally closed 	Flange acc. to DIN EN 1092 - 1	25	11.56	0...145	302	1.65	-	o. r.	o. r.	o. r.
							2.56	o. r.	-	-
	Flange acc. to DIN EN 1092 - 1	32	18.50	0...145	302	1.65	-	o. r.	o. r.	o. r.
							2.56	o. r.	-	-
	Flange acc. to DIN EN 1092 - 1 DN 40	32	18.50	0...145	302	1.65	-	o. r.	o. r.	o. r.
							2.56	o. r.	-	-

- = not available
 o. r. = on request
 1.) Maximum allowable working pressure

8.7. Ordering chart standard version DN 50

Note:

- Please note that the cable plug **Type 2518** ▶ is included. Further versions are available on request. For more information on the cable plug, see **“Cable plug Type 2518, form A according to DIN EN 175301 - 803” on page 17.**
- For AC voltage versions a cable plug with rectifier is included in the scope of delivery.

Circuit function	Port connection	Orifice [mm]	C _v value water [gal/min]	Pressure range (MAWP ^{1.)} [psi]	Max. medium temperature [°F]	Coil size [inch]	Article no.	
							024/DC	120/50...60 or DC
							[V/Hz]	[V/Hz]
Stainless steel/brass body, seal material PTFE/graphite								
CF A 2/2-way solenoid valve Servo-controlled Normally closed 	NPT 2	50	41.62	0...145	302	2.83	o. r.	o. r.

o. r. = on request
 1.) Maximum allowable working pressure

DTS 1000583397 EN Version: A Status: RL (released | freigegeben | validé) printed: 15.01.2024

Steam version with valve seat in stainless steel DN 50

Note:

- Please note that the cable plug **Type 2518** is included. Further versions are available on request. For more information on the cable plug, see **“Cable plug Type 2518, form A according to DIN EN 175301-803” on page 17.**
- For AC voltage versions a cable plug with rectifier is included in the scope of delivery.

Circuit function	Port connection	Orifice [mm]	C _v value water [gal/min]	Pressure range (MAWP ¹⁾) [psi]	Max. medium temperature [°F]	Coil size [inch]	Article no.	
							024/DC	120/50...60 or DC
							[V/Hz]	[V/Hz]
Stainless steel/brass body, seal material PTFE/graphite								
CF A 2/2-way solenoid valve Servo-controlled Normally closed 	NPT 2	50	41.62	0...145	302	2.83	467932	o. r.
	Flange acc. to DIN EN 1092-1	50	41.62	0...145	302	2.83	363051	o. r.

o. r. = on request
1.) Maximum allowable working pressure

8.8. Ordering chart explosion proof version DN 13...DN 25

Coil UL Listed (cULus) for hazardous locations, Class 1, Division 2 cable version

Note:

With 3 m/9'10" cable as standard. Other lengths on request.

Circuit function	Port connection	Orifice [mm]	C _v value water [gal/min]	Pressure range (MAWP ¹⁾) [psi]	Max. medium temperature [°F]	Coil size [inch]	Article no.	
							024/50...60 or DC	120/60
							[V/Hz]	[V/Hz]
Brass body, seal material PTFE/FKM								
CF A 2/2-way solenoid valve Servo-controlled Normally closed 	NPT 1/2	13	4.28	0...145	194	1.65	o. r.	o. r.
	NPT 3/4	20	6.47	0...145	194	1.65	o. r.	o. r.
	NPT 1	25	11.56	0...145	194	1.65	o. r.	o. r.

o. r. = on request
1.) Maximum allowable working pressure

Coil UL Listed (cULus) for hazardous locations, Class 1, Division 2 terminal box version

Circuit function	Port connection	Orifice [mm]	C _v value water [gal/min]	Pressure range (MAWP ¹⁾) [psi]	Max. medium temperature [°F]	Coil size [inch]	Article no.	
							024/50...60 or DC	120/60
							[V/Hz]	[V/Hz]
Brass body, seal material PTFE/FKM								
CF A 2/2-way solenoid valve Servo-controlled Normally closed 	NPT 1/2	13	4.28	0...145	194	1.65	o. r.	o. r.
	NPT 3/4	20	6.47	0...145	194	1.65	o. r.	o. r.
	NPT 1	25	11.56	0...145	194	1.65	o. r.	o. r.

o. r. = on request
1.) Maximum allowable working pressure

DTS 1000583397 EN Version: A Status: RL (released | freigegeben | valide) printed: 15.01.2024

Further versions on request	
Approval <ul style="list-style-type: none"> UL Listed UL Recognized UL Listed for Hazardous Locations for USA and Canada ATEX/IECEX: Ex II 2G / Ex mb IIC T4 GB Ex II 2D / Ex mb IIIC T130 °C DB 	Voltage Further voltages on request
Process connection <ul style="list-style-type: none"> G RC 	Temperature Special temperature ranges

8.9. Ordering chart accessories

Cable plug Type 2518, form A according to DIN EN 175301 - 803

Note:

- Dimensions in mm
- For further versions see data sheet **Type 2518** ▶

Cable plug	Dimensions	Version	Voltage	Article no.
		Without circuitry (AC/DC)	0...250 V AC/DC	314802
		With LED (AC/DC)	12...24 V AC/DC	314812
		With LED and varistor (AC/DC)	12...24 V AC/DC	314820
		With rectifier, LED and varistor	12...24 V AC/DC	314816

Cable plug Type 2509, form A according to DIN EN 175301 - 803

Note:

- Dimensions in mm
- Without circuitry (standard)
- The cable plug meets the requirements for UL hazloc Div. 2.
- The cable plug Type 2509 meets the requirements in accordance with UL Listed (UL 429) in assembly with a Bürkert solenoid valve.
- Refer to data sheet **Type 2509** ▶ for more information about the cable plug.

Cable plug	Dimensions	Version	Voltage	Article no.
		Without circuitry	0...250 V AC/DC	137943

DTS 1000583397 EN Version: A Status: RL (released | freigegeben | validé) printed: 15.01.2024

Special tool to turn the terminal box

Note:

This special tool is not supplied with the valve.

Description	Components of the set	Article no.
Set SC02-AC10 	<ul style="list-style-type: none"> • Special wrench • Service manual 	293488 

DTS 1000583397 EN Version: A Status: RL (released | freigegeben | validé) printed: 15.01.2024

