



Servo-assisted 2/2-way piston valve

- Servo-assisted and compact piston valve with diameter of up to DN 13
- Vibration-resistant , screwed coil system
- Energy-saving double coil technology with kick and drop variant
- Safe opening with hard-coupled piston system
- Explosion proof versions

Product variants described in the data sheet may differ from the product presentation and description.

Can be combined with



Type 2518

Cable plug,
form A according to
DIN EN 175301 -803



Type 2509

Cable plug,
form A according to
DIN EN 175301-803



Type description

The 6240 valve is a servo-assisted piston valve. The stopper and plunger guiding tube are welded together to enhance pressure resistance and leak-tightness. Various seal material combinations are available depending on the application. The housing design and surface quality enable maximum flow rates. The coils are moulded with chemically resistant epoxy. An optional sliding ring bearings increases the life cycle with dry gases. To reduce power consumption in operation, coils with Kick and Drop electronics assembly (double coil technology) are available.



Table of contents

1. General technical data	4
2. Circuit functions	5
3. Approvals and conformities	5
3.1. General notes.....	5
3.2. Conformity	5
3.3. Standards.....	5
3.4. Explosion protection	6
3.5. North America (USA/Canada)	7
3.6. Foods and beverages/Hygiene	7
3.7. Others	7
Oxygen.....	7
Fuel gases.....	7
4. Materials	8
4.1. Bürkert resistApp	8
4.2. Material specifications	8
Standard version.....	8
High pressure version up to 3626 psi bar (PN25) or 2321 psi (PN16) – DN 6	9
High pressure version up to 3626 psi (PN25) – DN 12.....	9
Steam version (NA67) – DN 13.....	10
5. Dimensions	11
5.1. Standard version	11
5.2. High pressure version up to 3626 psi (PN25) or 2321 psi (PN16) – DN 6.....	12
5.3. High pressure version up to 3626 psi (PN25) – DN 12.....	13
5.4. Version for self-service car wash up to 2321 psi (PN16) – Type 8820-6240.....	14
5.5. Coil UL Listed (cULus) for hazardous locations, Class I, Division 2	15
5.6. DN 13 version	16
6. Performance specifications	17
6.1. Power consumption	17
7. Product accessories	17
7.1. Special tool to turn the terminal box.....	17
8. Ordering information	18
8.1. Bürkert eShop.....	18
8.2. Bürkert product filter.....	18
8.3. Bürkert Product Enquiry Form	18
8.4. Ordering chart standard version elastomer sealing up to 232 psi	19
UL Recognized.....	19
UL Listed.....	19
8.5. Ordering chart standard version up to 363 psi	20
UL Recognized.....	20
UL Listed.....	20
8.6. Ordering chart high pressure version DN 6 – pressure ranges up to 2321 psi (PN16) with coil UL Recognized (cURus).....	21
8.7. Ordering chart high pressure version DN 6 – pressure ranges up to 3626 psi (PN25) with coil UL Recognized (cURus).....	21
8.8. Ordering chart high pressure version DN 12 – pressure range up to 3626 psi (PN25) with coil UL Recognized (cURus).....	22
8.9. Ordering chart version self-service car wash 1740 psi (PN16) – Type 8820-6240 with coil UL Recognized (cURus).....	22
8.10. Ordering chart steam version DN 13 with coil UL Recognized (cURus).....	23

DTS 1000581100 EN Version: D Status: RL (released | freigegeben | valide) printed: 15.05.2024

- 8.11. Ordering chart coil UL Listed (cULus) for hazardous locations, Class I, Division 223
 - Standard version with cable coil23
 - High pressure version up to 3626 psi (PN25) or 2321 psi (PN16) with cable coil24
- 8.12. Ordering chart accessories25
 - Cable plug Type 2518, form A according to DIN EN 175301 - 80325
 - Cable plug Type 2509, form A according to DIN EN 175301 - 80325
 - Special tool to turn the terminal box25
 - Mounting bracket26

DTS 1000581100 EN Version: D Status: RL (released | freigegeben | validé) printed: 15.05.2024



1. General technical data

Product properties	
Dimensions	Further information can be found in chapter "5. Dimensions" on page 11.
Material	
Body	Brass, stainless steel 1.4404 / 316L
Coil	Epoxy
Orifice	DN 6, DN 12, DN 13 (steam version)
Circuit function	A and B Further information can be found in chapter "2. Circuit functions" on page 5.
Thermal insulation class of solenoid coil	Epoxy coil class H
Performance data	
Duty cycle	100 % continuous operation
Switching time ¹⁾	
Standard version DN 6	Opening: 10...20 ms Closing: 40...50 ms
Standard version DN 12	Opening: 20...40 ms Closing: 80...100 ms
Steam version DN 13	Opening: 80...100 ms Closing: 200...300 ms
High pressure version PN16 and PN25	Opening: 100...200 ms Closing: 300...600 ms
Electrical data	
Operating voltage	24 V/DC, 24 V/50 Hz, 24 V/60 Hz, 110 V/50 Hz, 120 V/60 Hz, 230 V/50 Hz, 240 V/60 Hz (further voltages on request)
Power consumption	Further information can be found in chapter "6.1. Power consumption" on page 17.
Voltage tolerance	± 10 %
Medium data	
Operating medium ²⁾	Neutral gases and liquids (e.g. compressed air, water, hydraulic oil, steam and hot mediums)
Medium temperature	
Standard version	Seat seal/External seal FKM/FKM: + 14 °F...+284 °F EPDM/EPDM: -22 °F...+248 °F PTFE/FKM: + 14 °F...+284 °F
High temperature version	PTFE/PEEK DN 6: -40 °F...+356 °F PTFE/PEEK DN 12: -40 °F...+284 °F
Steam version DN 13	FKM/FKM: +32 °F...+284 °F
Approval DIN EN 161 (PO17)	NBR/NBR (PO17): + 14 °F...+176 °F
High pressure version up to 250 bar (PN25) or 160 bar (PN16)	PCTFE/FKM: + 14 °F...+176 °F PCTFE/EPDM: -22 °F...+176 °F PCTFE/PEEK: -40 °F...+176 °F
Viscosity	Max. 21 cSt
Process/Port connection & communication	
Electrical connection	<ul style="list-style-type: none"> Plug contacts according to DIN EN 175 301 - 803 form A for cable plug Type 2518 ▶. Further information can be found in chapter "Cable plug Type 2518, form A according to DIN EN 175301 - 803" on page 25. Plug contacts according to DIN EN 175 301 - 803 form A for cable plug Type 2509 ▶. Further information can be found in chapter "Cable plug Type 2509, form A according to DIN EN 175301 - 803" on page 25.
Port connections	G ¼, G ⅜, G ½, NPT ¼, NPT ⅜, NPT ½ (Rc on request), steam version DN 13 also in G ¾
Approvals and conformities	
Degree of protection	IP65 with cable plug Type 2518 ▶ NEMA 4X with cable plug Type 2509 ▶ with stainless steel versions (other versions on request)
Explosion protection	Further information can be found in chapter "3.4. Explosion protection" on page 6.
North America (USA/Canada)	Further information can be found in chapter "3.5. North America (USA/Canada)" on page 7.
Foods and beverages/Hygiene	Further information can be found in chapter "3.6. Foods and beverages/Hygiene" on page 7.
Others	Further information can be found in chapter "3.7. Others" on page 7.
Environment and installation	
Installation position	As required, preferably with actuator upright
Ambient temperature	Max. + 131 °F

1.) Measurement at +68 °F, 87 psi at the valve outlet, opening: pressure build-up 0...90 %, closing: pressure reduction 100...10 %

2.) Medium resistance according to material combination

2. Circuit functions

Symbol	Description
	Circuit function A (CF A) 2/2-way solenoid valve Servo-controlled Normally closed
	Circuit function B (CF B) 2/2-way solenoid valve Servo-controlled Normally open

3. Approvals and conformities

3.1. General notes

- The approvals and conformities listed below must be stated when making enquiries. This is the only way to ensure that the product complies with all required specifications.
- Not all available verions can be supplied with the below mentioned approvals or conformities.

3.2. Conformity



In accordance with the Declaration of Conformity, the product is compliant with the EU Directives.

3.3. Standards

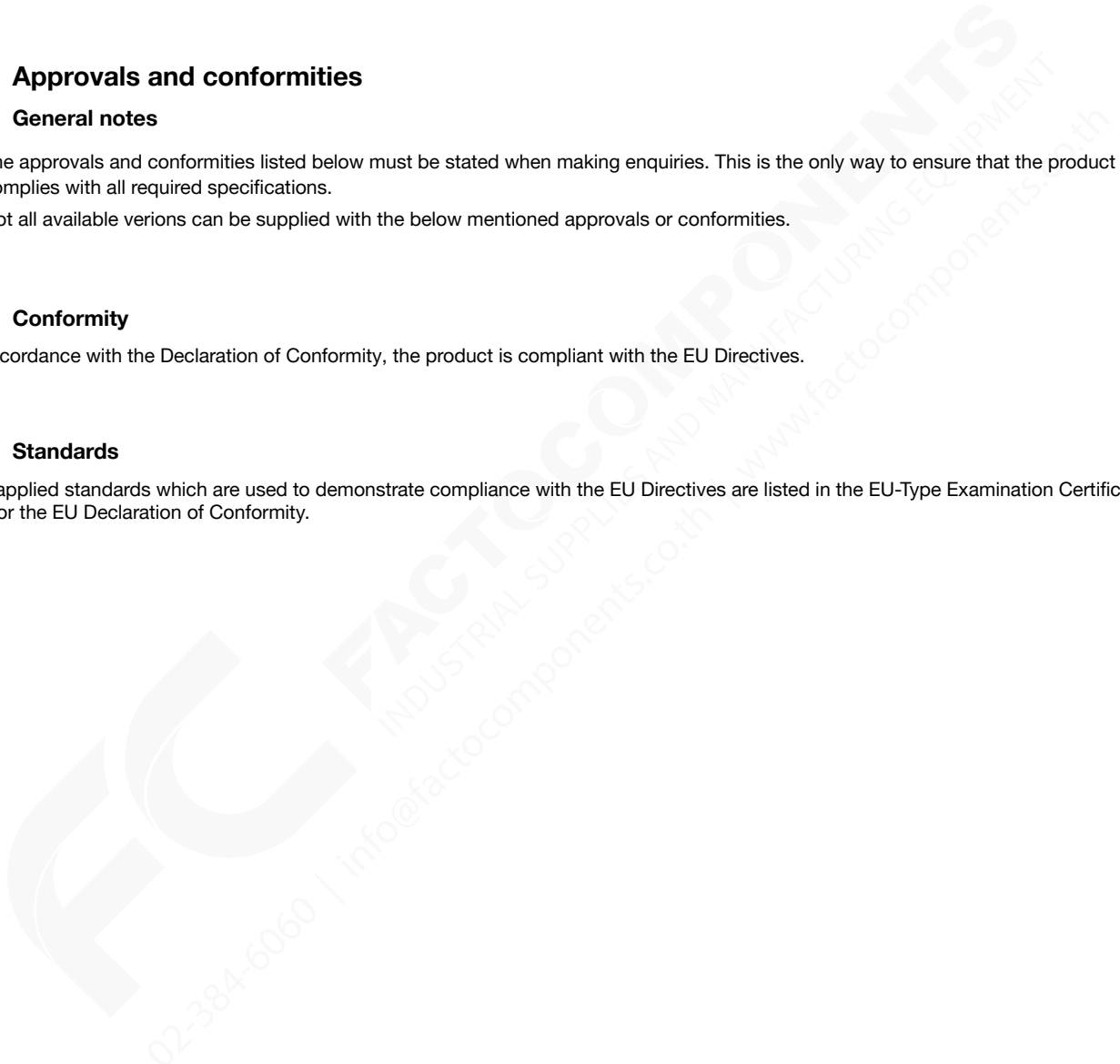
The applied standards which are used to demonstrate compliance with the EU Directives are listed in the EU-Type Examination Certificate and/or the EU Declaration of Conformity.



3.4. Explosion protection

Approval	Description										
 	<p>Optional: Explosion protection according to category 2 (zone 1/21)</p> <p>Ex marking of the components according to the following table:</p> <table border="1" style="width: 100%; border-collapse: collapse;"> <thead> <tr> <th style="background-color: #d9e1f2;">Coil Type AC10</th> <th style="background-color: #d9e1f2;">Coil Type AC19</th> </tr> </thead> <tbody> <tr> <td colspan="2" style="background-color: #d9e1f2;">Coil with cable outlet</td> </tr> <tr> <td> <p>ATEX: EPS 18 ATEX 1232 X II 2G Ex mb IIC T4 Gb II 2D Ex mb IIIC T130 °C Db</p> <p>IECEX: IECEX EPS 18.0110 X Ex mb IIC T4 Gb Ex mb IIIC T130 °C Db</p> </td> <td> <p>ATEX: EPS 16 ATEX 1072 X II 2G Ex mb IIC T4 Gb II 2D Ex mb IIIC T130 °C Db</p> <p>IECEX: IECEX EPS 16.0030 X II 2G Ex mb IIC T4 Gb II 2D Ex mb IIIC T130 °C Db</p> </td> </tr> <tr> <td colspan="2" style="background-color: #d9e1f2;">Coil with terminal box</td> </tr> <tr> <td> <p>ATEX: EPS 18 ATEX 1232 X II 2G Ex eb mb IIC T4 Gb II 2D Ex mb tb IIIC T130 °C Db</p> <p>IECEX: IECEX EPS 18.0110 X Ex eb mb IIC T4 Gb Ex mb tb IIIC T130 °C Db</p> </td> <td> <p>ATEX: EPS 16 ATEX 1072 X II 2G Ex eb mb IIC T4 Gb II 2D Ex mb tb IIIC T130 °C Db</p> <p>IECEX: IECEX EPS 16.0030 X II 2G Ex eb mb IIC T4 Gb II 2D Ex mb tb IIIC T130 °C Db</p> </td> </tr> </tbody> </table>	Coil Type AC10	Coil Type AC19	Coil with cable outlet		<p>ATEX: EPS 18 ATEX 1232 X II 2G Ex mb IIC T4 Gb II 2D Ex mb IIIC T130 °C Db</p> <p>IECEX: IECEX EPS 18.0110 X Ex mb IIC T4 Gb Ex mb IIIC T130 °C Db</p>	<p>ATEX: EPS 16 ATEX 1072 X II 2G Ex mb IIC T4 Gb II 2D Ex mb IIIC T130 °C Db</p> <p>IECEX: IECEX EPS 16.0030 X II 2G Ex mb IIC T4 Gb II 2D Ex mb IIIC T130 °C Db</p>	Coil with terminal box		<p>ATEX: EPS 18 ATEX 1232 X II 2G Ex eb mb IIC T4 Gb II 2D Ex mb tb IIIC T130 °C Db</p> <p>IECEX: IECEX EPS 18.0110 X Ex eb mb IIC T4 Gb Ex mb tb IIIC T130 °C Db</p>	<p>ATEX: EPS 16 ATEX 1072 X II 2G Ex eb mb IIC T4 Gb II 2D Ex mb tb IIIC T130 °C Db</p> <p>IECEX: IECEX EPS 16.0030 X II 2G Ex eb mb IIC T4 Gb II 2D Ex mb tb IIIC T130 °C Db</p>
	Coil Type AC10	Coil Type AC19									
	Coil with cable outlet										
	<p>ATEX: EPS 18 ATEX 1232 X II 2G Ex mb IIC T4 Gb II 2D Ex mb IIIC T130 °C Db</p> <p>IECEX: IECEX EPS 18.0110 X Ex mb IIC T4 Gb Ex mb IIIC T130 °C Db</p>	<p>ATEX: EPS 16 ATEX 1072 X II 2G Ex mb IIC T4 Gb II 2D Ex mb IIIC T130 °C Db</p> <p>IECEX: IECEX EPS 16.0030 X II 2G Ex mb IIC T4 Gb II 2D Ex mb IIIC T130 °C Db</p>									
Coil with terminal box											
<p>ATEX: EPS 18 ATEX 1232 X II 2G Ex eb mb IIC T4 Gb II 2D Ex mb tb IIIC T130 °C Db</p> <p>IECEX: IECEX EPS 18.0110 X Ex eb mb IIC T4 Gb Ex mb tb IIIC T130 °C Db</p>	<p>ATEX: EPS 16 ATEX 1072 X II 2G Ex eb mb IIC T4 Gb II 2D Ex mb tb IIIC T130 °C Db</p> <p>IECEX: IECEX EPS 16.0030 X II 2G Ex eb mb IIC T4 Gb II 2D Ex mb tb IIIC T130 °C Db</p>										
	<p>Optional: Explosion protection according to category 3 (zone 2/22)</p> <p>Ex marking of the components according to the following table:</p> <table border="1" style="width: 100%; border-collapse: collapse;"> <thead> <tr> <th style="background-color: #d9e1f2;">Coil Type AC10</th> <th style="background-color: #d9e1f2;">Coil Type AC19</th> </tr> </thead> <tbody> <tr> <td colspan="2" style="background-color: #d9e1f2;">Coil with plug contacts form A and cable plug Type 2509</td> </tr> <tr> <td> <p>ATEX: EPS 18 ATEX 1232 X II 2G Ex mb IIC T4 Gb II 2D Ex mb IIIC T130 °C Db</p> <p>IECEX: IECEX EPS 18.0110 X Ex mb IIC T4 Gb Ex mb IIIC T130 °C Db</p> </td> <td> <p>ATEX: EPS 16 ATEX 1072 X II 2G Ex mb IIC T4 Gb II 2D Ex mb IIIC T130 °C Db</p> <p>IECEX: IECEX EPS 16.0030 X II 2G Ex mb IIC T4 Gb II 2D Ex mb IIIC T130 °C Db</p> </td> </tr> </tbody> </table>	Coil Type AC10	Coil Type AC19	Coil with plug contacts form A and cable plug Type 2509		<p>ATEX: EPS 18 ATEX 1232 X II 2G Ex mb IIC T4 Gb II 2D Ex mb IIIC T130 °C Db</p> <p>IECEX: IECEX EPS 18.0110 X Ex mb IIC T4 Gb Ex mb IIIC T130 °C Db</p>	<p>ATEX: EPS 16 ATEX 1072 X II 2G Ex mb IIC T4 Gb II 2D Ex mb IIIC T130 °C Db</p> <p>IECEX: IECEX EPS 16.0030 X II 2G Ex mb IIC T4 Gb II 2D Ex mb IIIC T130 °C Db</p>				
Coil Type AC10	Coil Type AC19										
Coil with plug contacts form A and cable plug Type 2509											
<p>ATEX: EPS 18 ATEX 1232 X II 2G Ex mb IIC T4 Gb II 2D Ex mb IIIC T130 °C Db</p> <p>IECEX: IECEX EPS 18.0110 X Ex mb IIC T4 Gb Ex mb IIIC T130 °C Db</p>	<p>ATEX: EPS 16 ATEX 1072 X II 2G Ex mb IIC T4 Gb II 2D Ex mb IIIC T130 °C Db</p> <p>IECEX: IECEX EPS 16.0030 X II 2G Ex mb IIC T4 Gb II 2D Ex mb IIIC T130 °C Db</p>										

DTS 1000581100 EN Version: D Status: RL (released | freigegeben | valide) printed: 15.05.2024

3.5. North America (USA/Canada)

Approval	Description
	Optional: UL Listed for the USA (valid for valves) The valves are UL Listed for the USA according to: <ul style="list-style-type: none"> UL 429 (electrically operated valves)
	Optional: UL Hazardous Locations – Explosion Protection (valid for coils) UL Listed for Hazardous Locations for USA and Canada Class I, Zone 1 Class I, Division 2, Group A, B, C and D Class II + III, Division 2, Group F and G
	Optional: UL Recognized for the USA (valid for valves) The valves are UL Recognized for the USA according to: <ul style="list-style-type: none"> UL 429 (electrically operated valves)
	Optional: CSA for Canada (valid for valves) The valves are CSA approved for Canada according to: <ul style="list-style-type: none"> CSA 139 (electrically operated valves)

3.6. Foods and beverages/Hygiene

Conformity	Description
FDA	FDA – Code of Federal Regulations (valid for the variable code PL02, PL03) All wetted materials are compliant with the Code of Federal Regulations published by the FDA (Food and Drug Administration, USA) according to the manufacturer’s declaration.
	EC Regulation 1935/2004 of the European Parliament and of the Council (valid for the variable code PL01, PL02) All wetted materials are compliant with EC Regulation 1935/2004/EC according to the manufacturer’s declaration.

3.7. Others

Oxygen

Conformity	Description
	Optional: Suitability for oxygen (valid for the variable code NL02) The products are suitable for use with gaseous oxygen, according to the manufacturer’s declaration.

Fuel gases

Conformity	Description
	Fuel gases (valid for the variable code PO17) The products comply with: <ul style="list-style-type: none"> Regulation (EU) 2016/426 – Appliances burning gaseous fuels and DVGW DIN EN 161 (Automatic shut-off valves for gas burners and gas appliances), class B
	DIN EN 549:2023-07 certification The wetted valve seals are compliant with DIN EN 549:2023-07 (Rubber materials for seals and diaphragms for gas appliances and gas equipment) for medium temperatures of -10 °C...+80 °C.

DTS 1000581100 EN Version: D Status: RL (released | freigegeben | validé) printed: 15.05.2024

4. Materials

4.1. Bürkert resistApp

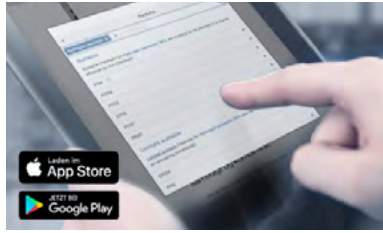

Bürkert resistApp – Chemical resistance chart

You want to ensure the reliability and durability of the materials in your individual application case? Verify your combination of media and materials on our website or in our resistApp.

[Start chemical resistance check](#)

4.2. Material specifications

Standard version

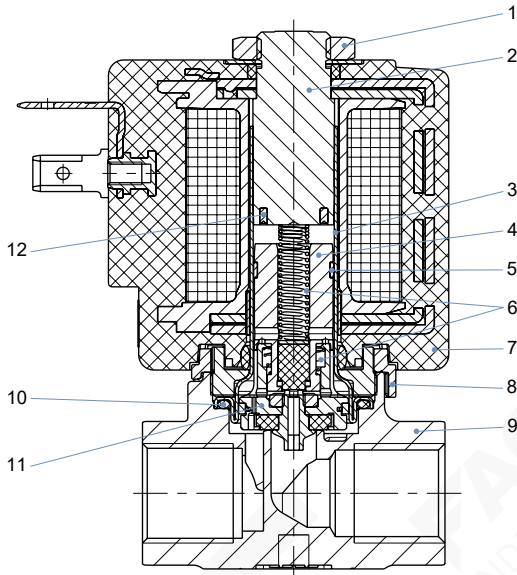

No.	Element	Material
1	Nut	Steel (surface finish thick film passivated) (Brass version) Stainless steel 1.4305/303 ^{1.)} PTFE (Stainless steel version)
2	Stopper	Stainless steel 1.4113/434 ^{1.)}
3	Armature guide tube	Stainless steel 1.4303/305 ^{1.)} /308 ^{1.)}
4	Core	Stainless steel 1.4113/434 ^{1.)}
5	Guide ring	PTFE coal-filled
6	Springs	Stainless steel 1.4310/301 ^{1.)}
7	Coil	Epoxy
8	Safety lock	PPS
9	Body	Brass/stainless steel 1.4404/316L ^{1.)} (CF3M)
10	Seal facing outwards	FKM/EPDM/PEEK (high temperature version)
11	Piston complete	Brass/stainless steel 1.4305/303 ^{1.)} Stainless steel PEEK PTFE coal-filled FKM/EPDM/PTFE (PTFE for high temperature and PTFE/FKM for high pressure versions)
12	Shading ring	Copper/silver

1.) Material designation according to AISI

High pressure version up to 3626 psi bar (PN25) or 2321 psi (PN16) – DN 6

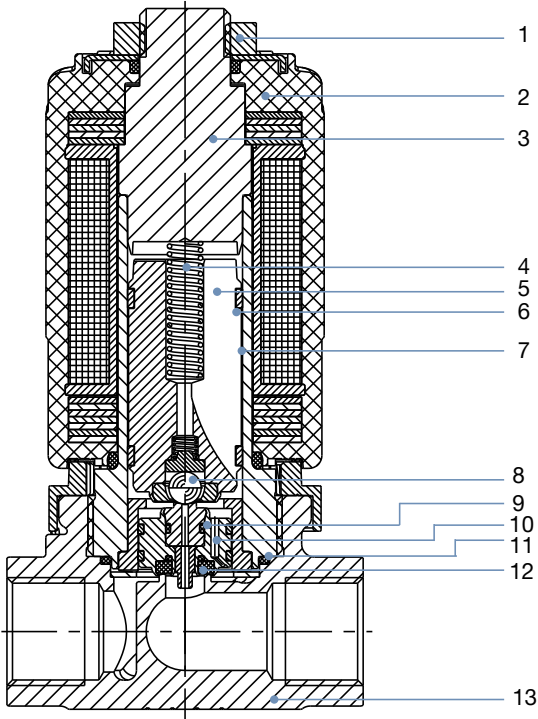

No.	Element	Material
1	Nut	Stainless steel 1.4305/303 ^{1.)}
2	Coil	Epoxy
3	Stopper	Stainless steel 1.4523/316 ^{1.)}
4	Spring	Stainless steel 1.4310/301 ^{1.)}
5	Core coupling	Stainless steel 1.4113/434 ^{1.)} , 1.4305/303 ^{1.)}
6	Glide ring	PTFE coal-filled
7	Guide tube	Stainless steel 1.4571/316 Ti ^{1.)}
8	Core seal	Ceramic ball
9	Piston coupling	Stainless steel 1.4305/303 ^{1.)} , PEEK, PTFE coal-filled
10	Piston guide	Stainless steel 1.4305/303 ^{1.)}
11	Seal	FKM, EPDM
12	Seat seal	PCTFE
13	Body	Stainless steel 1.4404/316L ^{1.)} (CF3M)

1.) Material designation according to AISI

High pressure version up to 3626 psi (PN25) – DN 12

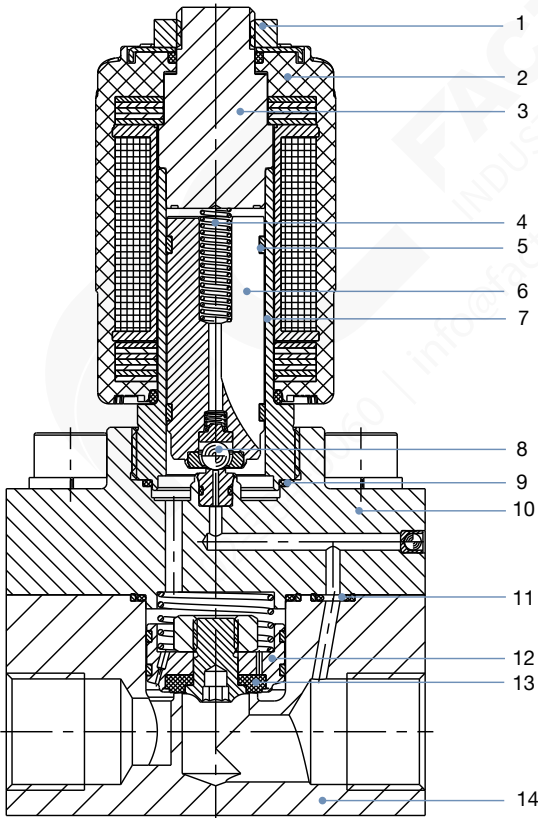

No.	Element	Material
1	Nut	Stainless steel 1.4305/303 ^{1.)} PTFE coated
2	Coil	Epoxy
3	Stopper	Stainless steel 1.4523/316 ^{1.)}
4	Spring	Stainless steel 1.4310/301 ^{1.)}
5	Glide ring	PTFE coal-filled
6	Core coupling	Stainless steel 1.4113/434 ^{1.)} , 1.4305/303 ^{1.)}
7	Guide tube	Stainless steel 1.4571/316 Ti ^{1.)}
8	Core seal	Ceramic ball
9	Outer seal	FKM, EPDM
10	Flange coupling	Stainless steel 1.4404/316L (CF3M), PEEK, FKM/EPDM
11	Outer seal	FKM, EPDM
12	Piston coupling	Stainless steel 1.4305/303 ^{1.)} , PTFE coal-filled
13	Seat seal	PCTFE
14	Body	Stainless steel 1.4404/316L (CF3M)

1.) Material designation according to AISI

DTS 1000581100 EN Version: D Status: RL (released | freigegeben | validé) printed: 15.05.2024

Steam version (NA67) – DN 13

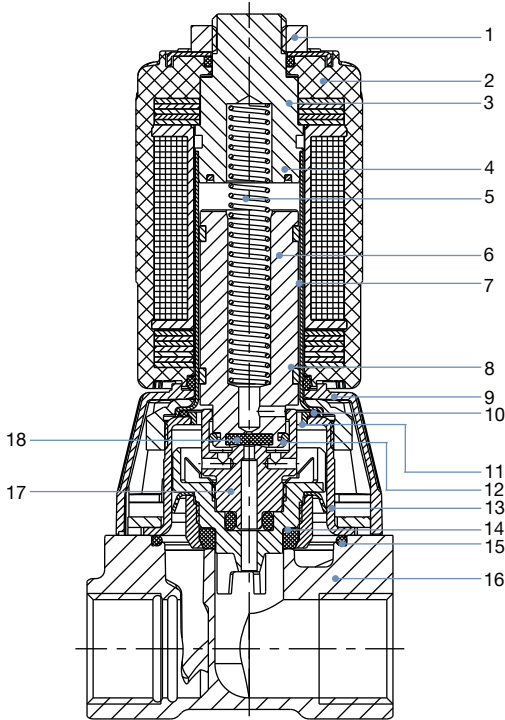

No.	Element	Material
1	Nut	Stainless steel 1.4305/303 ^{1.)}
2	Coil	Epoxy
3	Stopper	Stainless steel 1.4113/434 ^{1.)}
4	Shading ring	Silver
5	Spring	Stainless steel 1.4310/301 ^{1.)}
6	Core	Stainless steel 1.4113/434 ^{1.)}
7	Guide tube	Stainless steel 1.4303/305 ^{1.)} /308 ^{1.)}
8	Glide ring	PTFE coal filled
9	Cover	PA6
10	Seal	FKM
11	Support ring	PPS Fortron
12	Coupling ring	PEEK
13	Holding cap	Stainless steel 1.4301/304 ^{1.)}
14	Seat gasket	FKM
15	Outer seal	FKM
16	Body	Brass, stainless steel 1.4408/316 ^{1.)}
17	Piston coupling	Stainless steel 1.4401/316 ^{1.)} , PPS Fortron, PTFE, PEEK, FKM
18	Core seal	FKM

1.) Material designation according to AISI

DTS 1000581100 EN Version: D Status: RL (released | freigegeben | validé) printed: 15.05.2024

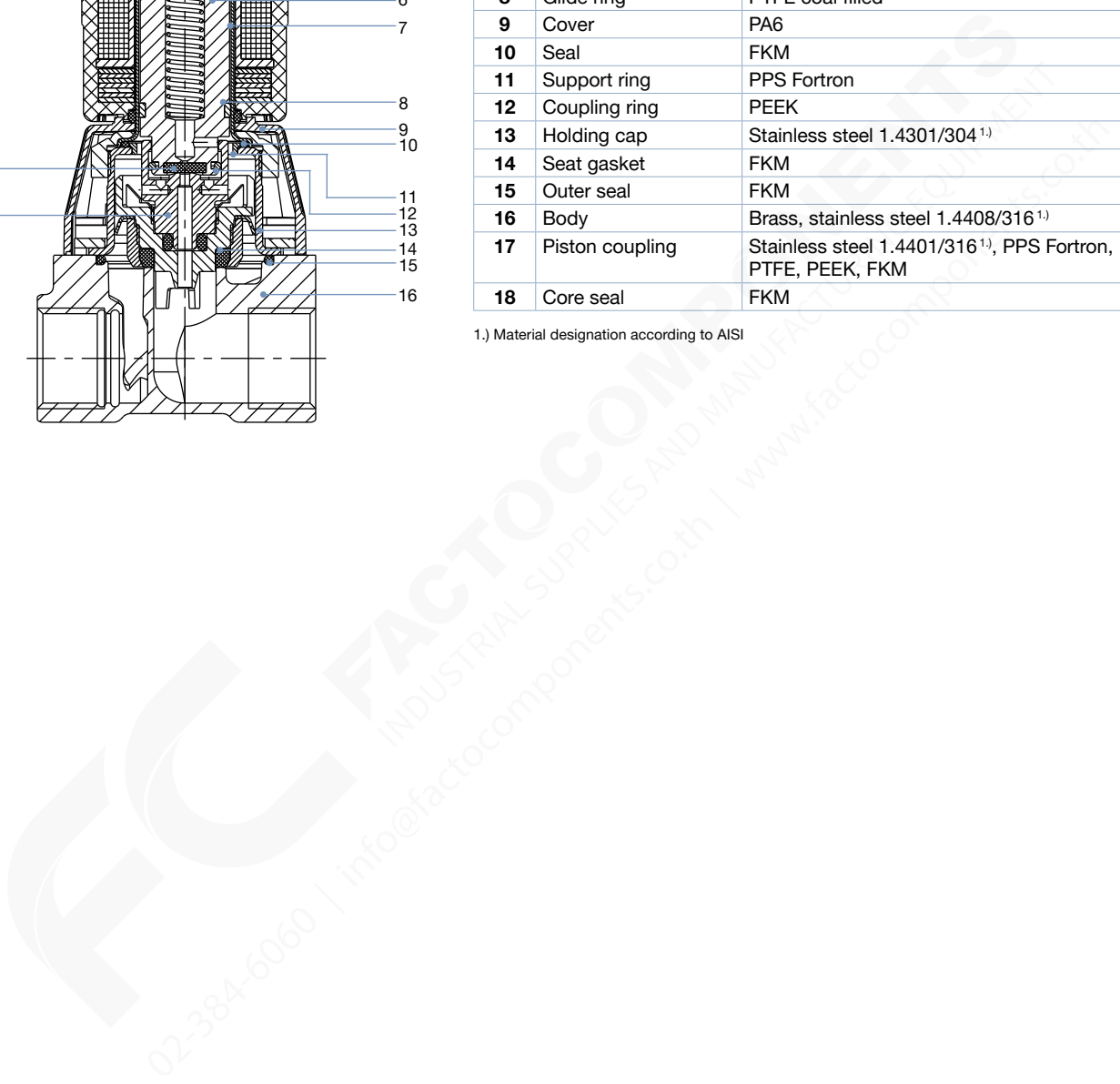

5. Dimensions

5.1. Standard version

Note:

Dimensions in mm [inch]

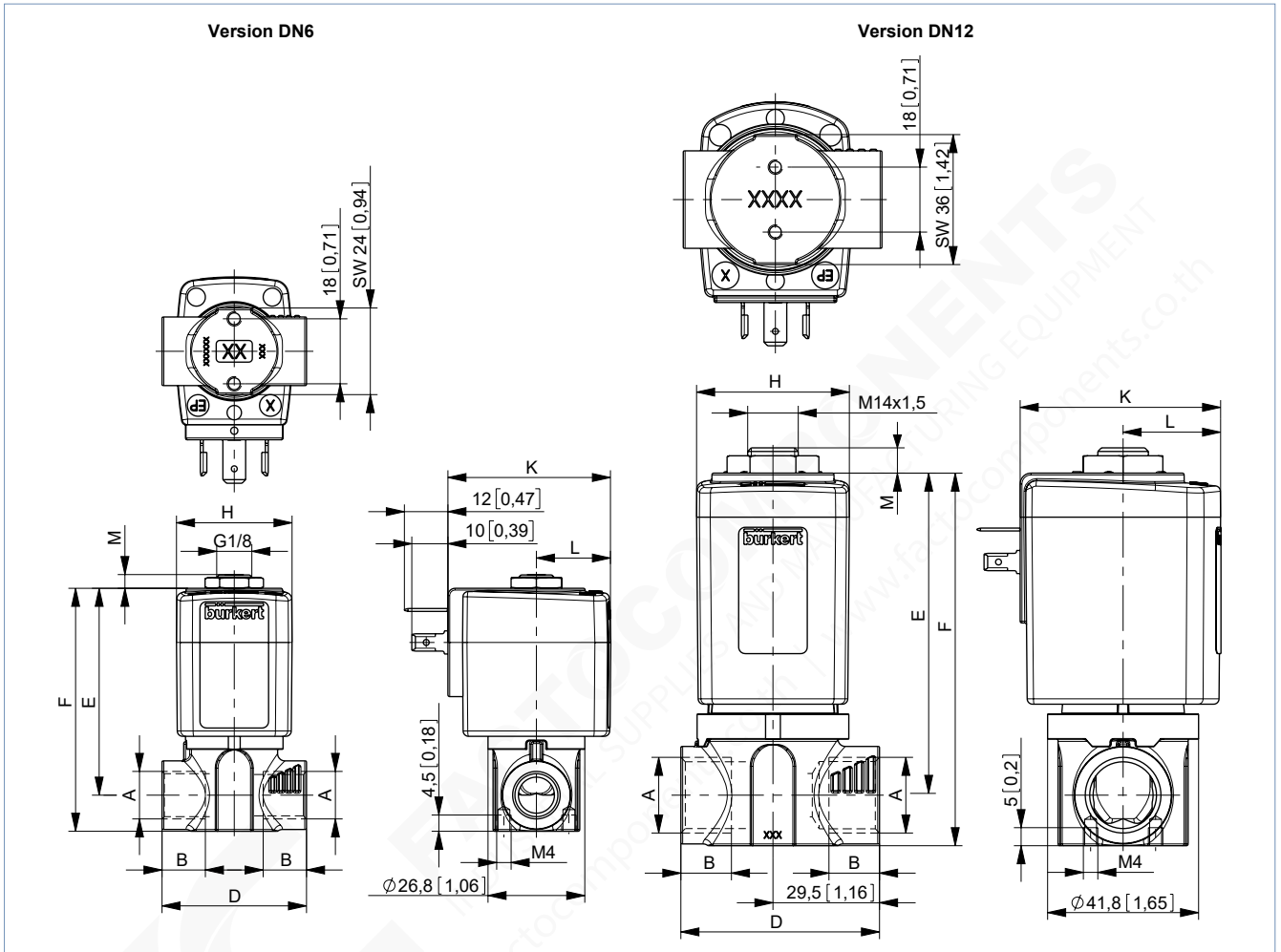

A (body connection)	B	D	E	F	H	K	L	M
[Zoll]	[mm] [in]	[mm] [in]	[mm] [in]	[mm] [in]	[mm] [in]	[mm] [in]	[mm] [in]	[mm] [in]
DN 6								
G ¼	12 0.47	40 1.57	57.3 2.26	67.3 2.65	32 1.26	45 1.77	20.5 0.81	3.7 0.15
NPT ¼	10 0.39							
RC ¼	9.7 0.38							
G ⅜	12 0.47	50 1.97	58.3 2.30	70.3 2.77				
NPT ⅜	10.3 0.41							
RC ⅜	10.1 0.40							
G ½	12 0.47	40 1.57	57.3 2.26	67.3 2.65	40 1.57	51 2.01	23.5 0.93	3.7 0.15
NPT ½	10 0.39							
RC ½	9.7 0.38							
G ¾	12 0.47	50 1.97	58.3 2.30	70.3 2.77				
NPT ¾	10.3 0.41							
RC ¾	10.1 0.40							
DN 12								
G ½	14 0.55	55 2.17	89 3.50	103 4.06	42 1.65	55.5 2.19	27 1.06	7 0.28
NPT ½	13.7 0.54							
RC ½	13.2 0.52							

DTS 1000581100 EN Version: D Status: RL (released | freigegeben | valide) printed: 15.05.2024

5.2. High pressure version up to 3626 psi (PN25) or 2321 psi (PN16) – DN 6

Note:

Dimensions in mm [inch]

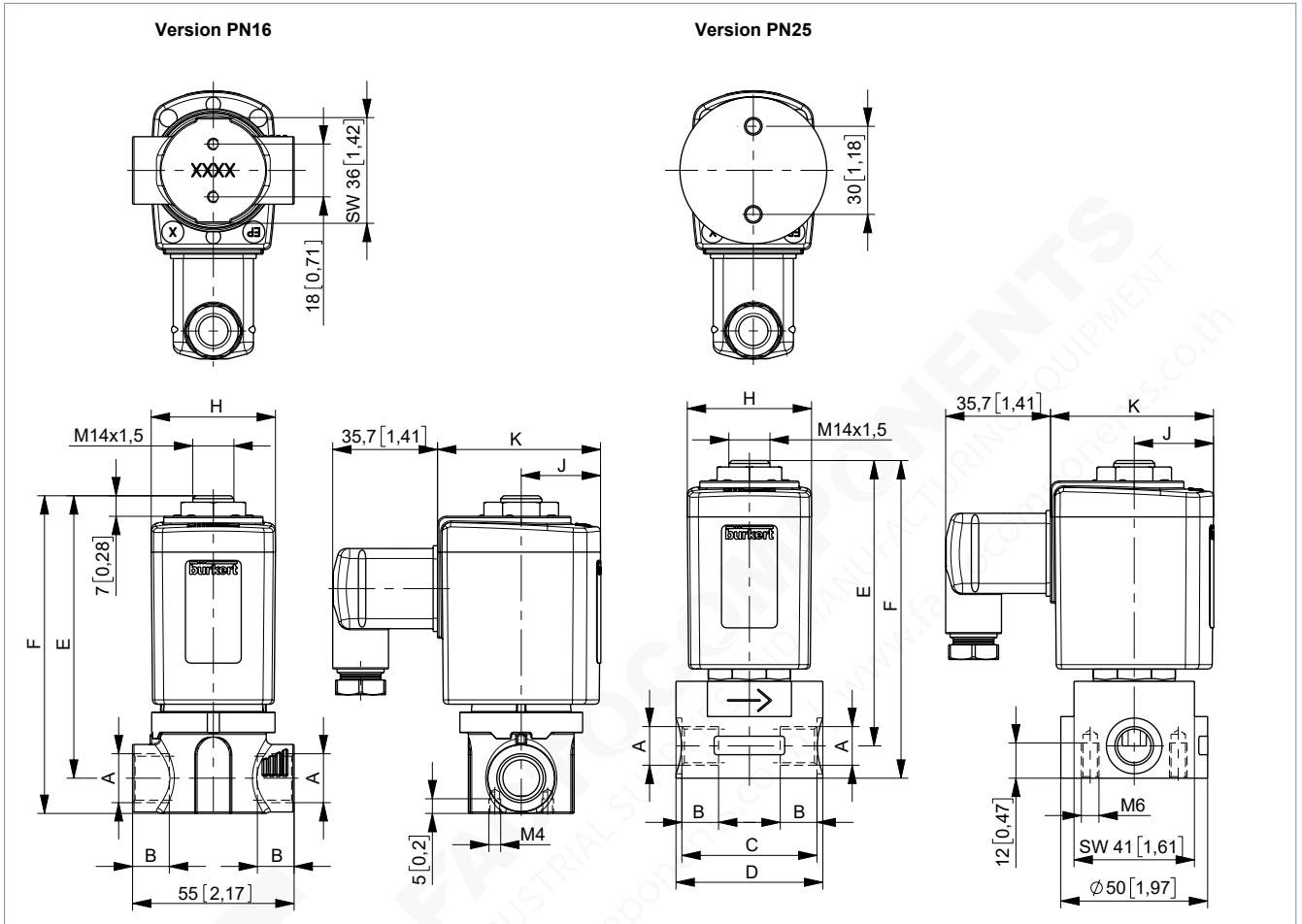

Coil size	H		J		K	
	[mm]	[in]	[mm]	[in]	[mm]	[in]
K	42	1.65	27	1.06	55.5	2.19
L	65	2.56	37.5	1.48	72	2.83

Version PN16						
A (body connection)	B		E		F	
[Zoll]	[mm]	[in]	[mm]	[in]	[mm]	[in]
G ¼	13	0.51	95.2	3.75	105.2	4.14
NPT ¼	10	0.39				
G ⅜	12	0.47	96.2	3.79	108.2	4.26
NPT ⅜	10.3	0.41				

Version PN25										
A (body connection)	B		C		D		E		F	
[Zoll]	[mm]	[in]	[mm]	[in]	[mm]	[in]	[mm]	[in]	[mm]	[in]
G ¼	13	0.51	46	1.81	Ø 50	Ø 1.97	97.2	3.83	108.2	4.26
NPT ¼	10	0.39								
G ⅜	12.5	0.49	44	1.73	44.4	1.75	98.7	3.89	111.2	4.38
NPT ⅜	10.3	0.41								

DTS 1000581100 EN Version: D Status: RL (released | freigegeben | valide) printed: 15.05.2024

5.3. High pressure version up to 3626 psi (PN25) – DN 12

Note:

Dimensions in mm [inch]

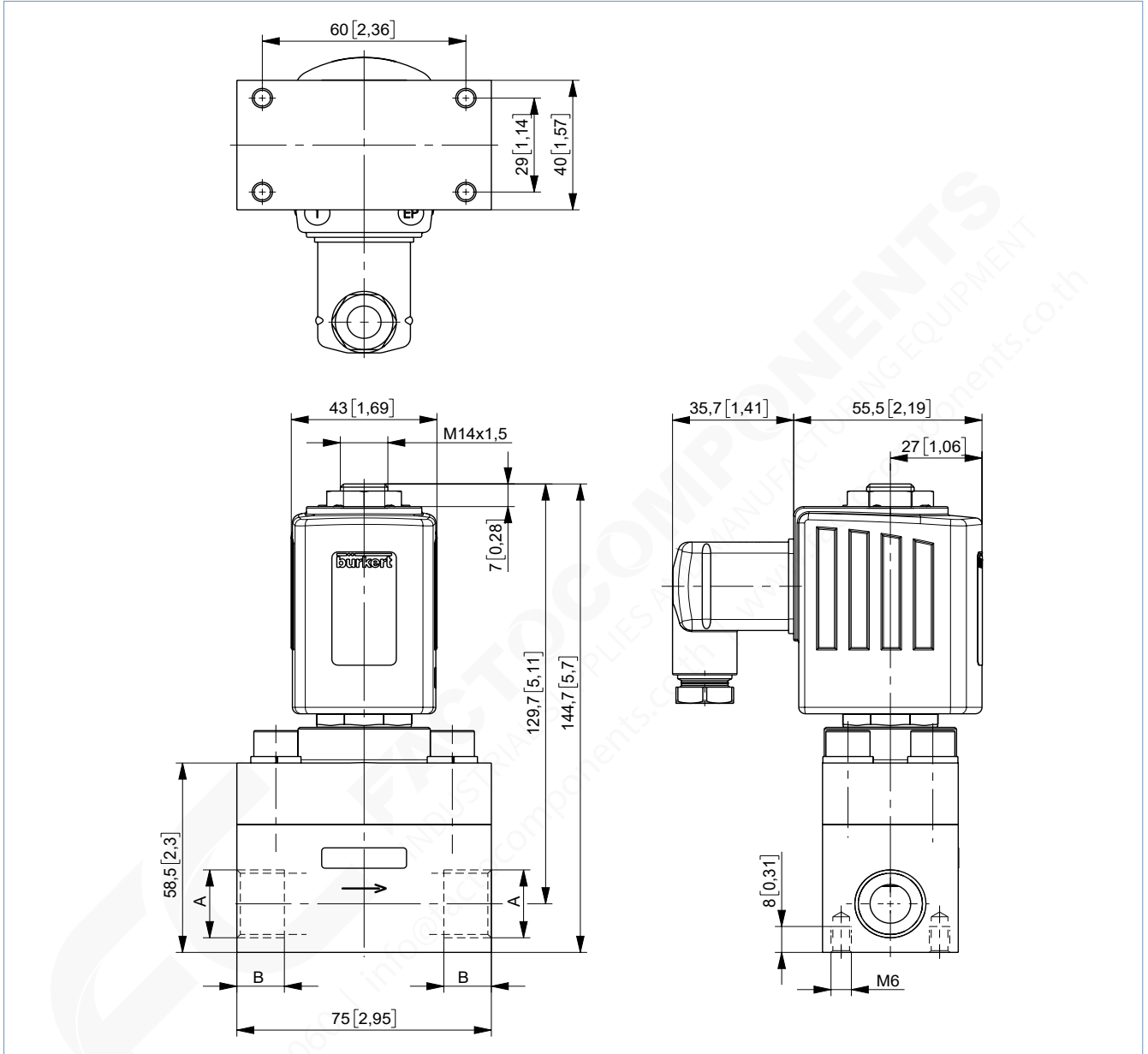

A (body connection) [Zoll]	B	
	[mm]	[in]
G ½	14	0.55
NPT ½	13.7	0.54

DTS 1000581100 EN Version: D Status: RL (released | freigegeben | valide) printed: 15.05.2024

5.4. Version for self-service car wash up to 2321 psi (PN16) – Type 8820 - 6240

Note:

Dimensions in mm [inch]

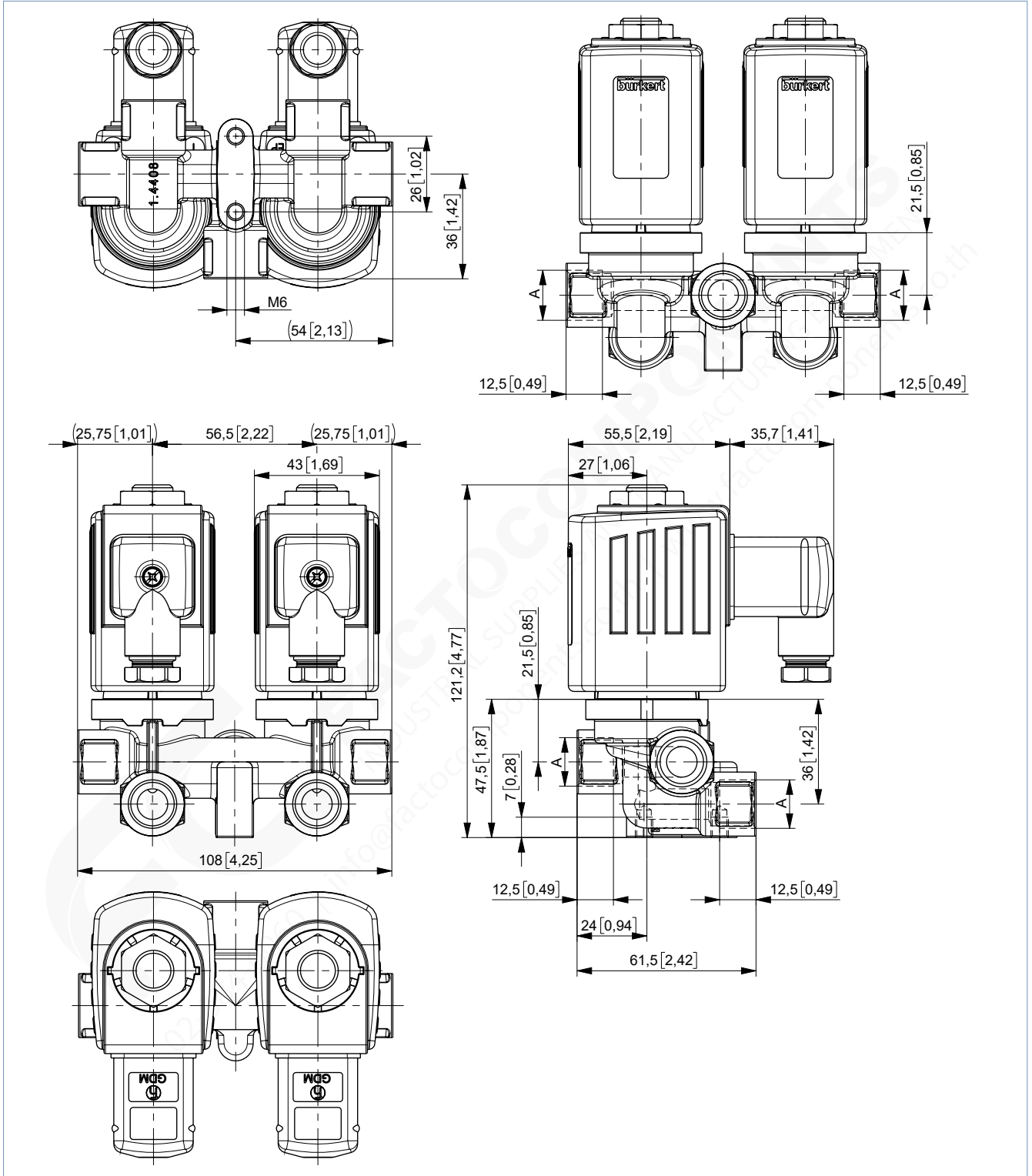

Version	A [Zoll]
AH40	G ¼
AH37	G ⅜

DTS 1000581100 EN Version: D Status: RL (released | freigegeben | valide) printed: 15.05.2024

5.5. Coil UL Listed (cULus) for hazardous locations, Class I, Division 2

Note:

Dimensions in mm [inch] apply exclusively to Ex version of the solenoid coil. For other dimensions see previous versions.

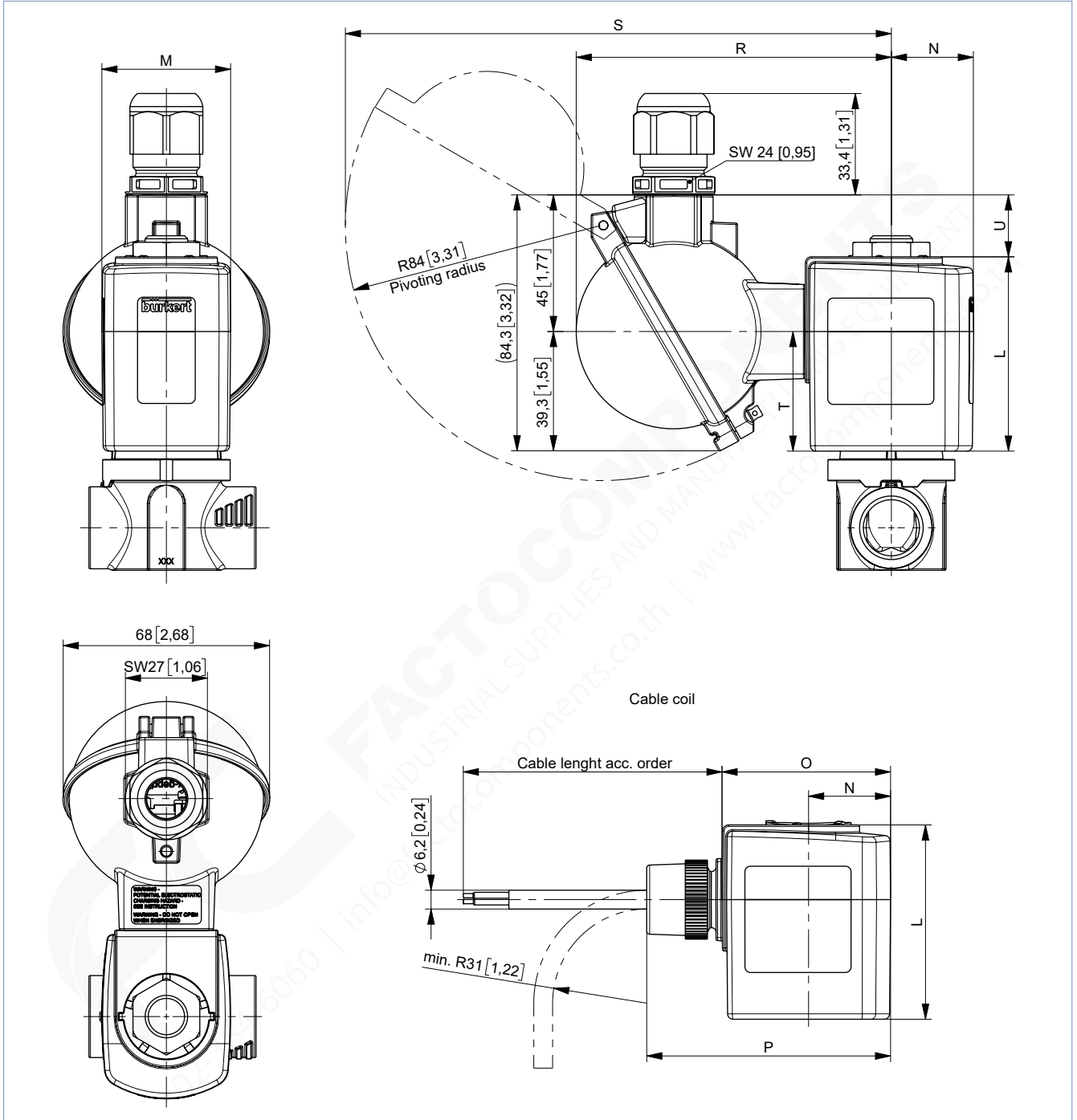

Coil dimensions		M		N		O		P		L		R		S		T		U	
Var. Code	Coil size	[mm]	[in]	[mm]	[in]	[mm]	[in]	[mm]	[in]	[mm]	[in]	[mm]	[in]	[mm]	[in]	[mm]	[in]	[mm]	[in]
PX58	6	40	1.57	23.5	0.93	52	2.05	74.8	2.94	41.3	1.63	102.8	4.05	177.5	6.99	26	1.02	29.7	1.17
PX38	K	42	1.65	27	1.06	55.5	2.19	80.3	3.16	64	2.52	104.8	4.13	179.8	7.08	39.4	1.55	20.4	0.80

DTS 1000581100 EN Version: D Status: RL (released | freigegeben | valide) printed: 15.05.2024

5.6. DN 13 version

Note:
Dimensions in mm [inch]

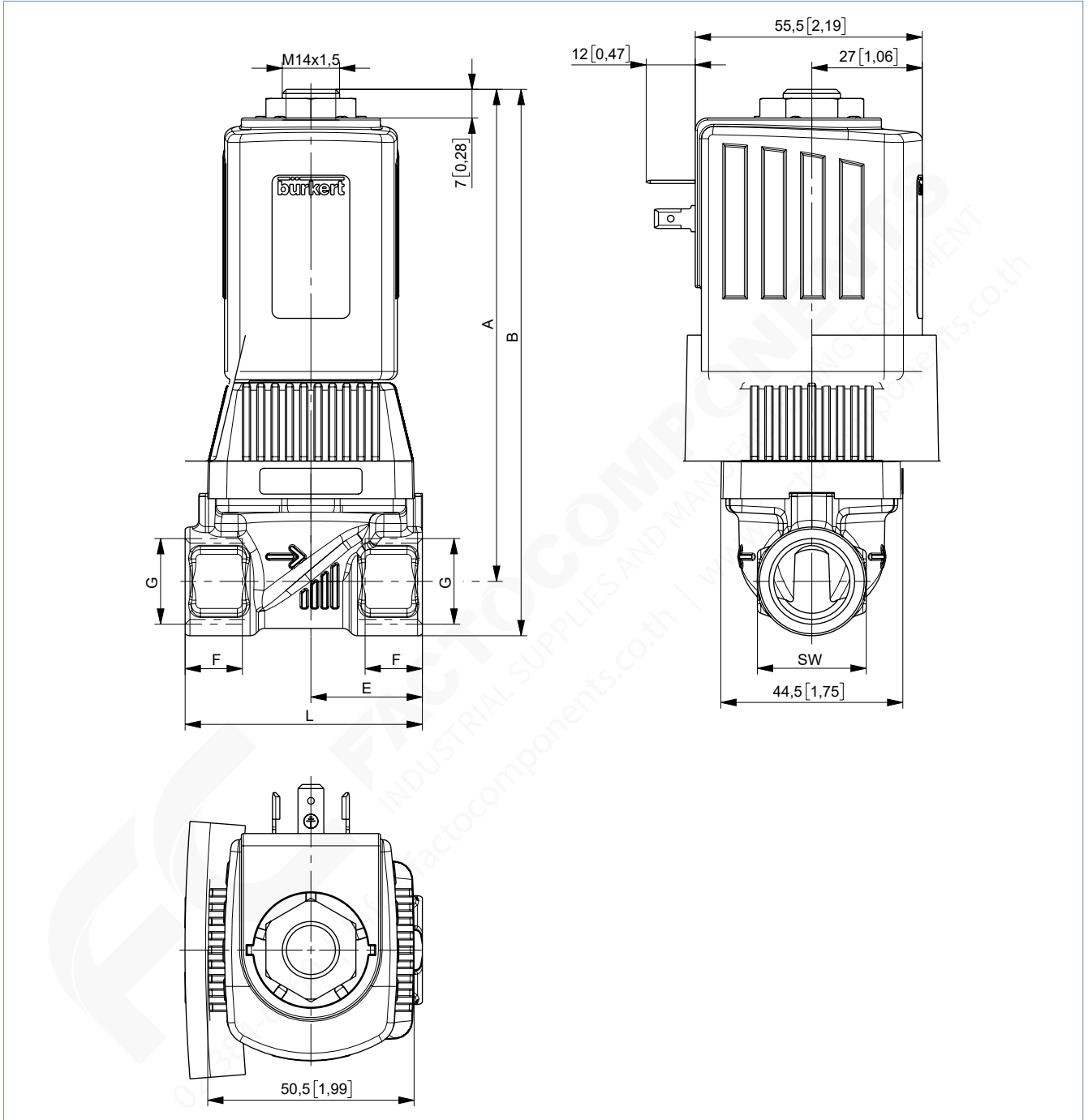

G (body connection) [Zoll]	Material	A		B		E		F		L		SW	
		[mm]	[in]	[mm]	[in]	[mm]	[in]	[mm]	[in]	[mm]	[in]	[mm]	[in]
G 1/2	Brass	120.35	4.74	133.85	5.27	27.25	1.07	14	0.55	58	2.28	27	1.06
NPT 1/2								13.7	0.54				
Rc 1/2								13.2	0.52				
G 1/2	Stainless steel	120.35	4.74	133.85	5.27	32.5	1.28	14	0.55	65	2.56	27	1.06
NPT 1/2								13.7	0.54				
Rc 1/2								13.2	0.52				

DTS 1000581100 EN Version: D Status: RL (released | freigegeben | valide) printed: 15.05.2024

G (body connection) [Zoll]	Material	A		B		E		F		L		SW	
		[mm]	[in]	[mm]	[in]	[mm]	[in]	[mm]	[in]	[mm]	[in]	[mm]	[in]
G 3/4	Brass and Stainless steel	122.35	4.82	138.35	5.45	32.5	1.28	16	0.63	65	2.56	32	1.26
NPT 3/4								14	0.55				
Rc 3/4								14.5	0.57				

6. Performance specifications

6.1. Power consumption

Note:

The Kick and Drop coil (AC/DC) features integrated electronics for short-term power increase and decrease in double coil technology.

Coil size [mm]	AC			DC		Kick and Drop coil (AC/DC)		
	Inrush	Hold		Cold	Warm	Cold Inrush	Cold Hold	Warm Hold
	[VA]	[VA]	[W]	[W]	[W]	[W] 500 ms	[W]	[W]
32 (5)	32	18	8	12	10	–	–	–
40 (6)	40	23	10	14	12	20	2	2
40 (6) ATEX	–	–	–	9	7.5	–	–	–
42 (K)	150	37	16	21	16	85	8.5	7
42 (K) ATEX	–	–	–	15	12	44	6.5	5.5
65 (L)	–	–	–	28	21	–	–	–

7. Product accessories

7.1. Special tool to turn the terminal box

Note:

Refer to chapter [“Special tool to turn the terminal box”](#) on page 25 for more order information.

DTS 1000581100 EN Version: D Status: RL (released | freigegeben | validé) printed: 15.05.2024

8. Ordering information

8.1. Bürkert eShop



Bürkert eShop – Easy ordering and quick delivery

You want to find your desired Bürkert product or spare part quickly and order directly? Our online shop is available for you 24/7. Sign up and enjoy all the benefits.

[Order online now](#)

8.2. Bürkert product filter



Bürkert product filter – Get quickly to the right product

You want to select products comfortably based on your technical requirements? Use the Bürkert product filter and find suitable articles for your application quickly and easily.

[Try out our product filter](#)

8.3. Bürkert Product Enquiry Form

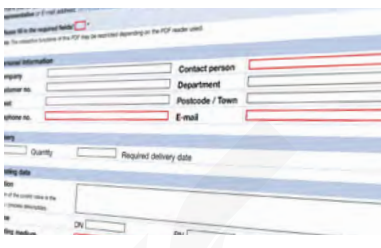

Bürkert Product Enquiry Form – Your enquiry quickly and compactly

Would you like to make a specific product enquiry based on your technical requirements? Use our Product Enquiry Form for this purpose. There you will find all the relevant information for your Bürkert contact. This will enable us to provide you with the best possible advice.

[Fill out the form now](#)

DTS 1000581100 EN Version: D Status: RL (released | freigegeben | validé) printed: 15.05.2024

8.4. Ordering chart standard version elastomer sealing up to 232 psi

UL Recognized

Note:

- Please note that the cable plug **Type 2518** ▶ is included. Further versions are available on request. For more information on the cable plug, see “[Cable plug Type 2518, form A according to DIN EN 175301 - 803](#)” on page 25.
- Further versions with alternative voltages, G or RC internal thread, seal material EPDM/EPDM available on request.

Circuit function	Port connection	Orifice [mm]	C _v value water [gal/min]	Pressure range (MAWP ^{1.)} [psi]	Coil size [mm/inch]	Article no.			
						024/DC [V/Hz]	024/60 [V/Hz]	120/60 [V/Hz]	240/60 [V/Hz]
NPT internal thread, seal material FKM/FKM									
CF A 2/2-way solenoid valve Servo-controlled Normally closed 	Brass body								
	NPT ¼	6.0	0.7	0...232	32 / 1.26	312949	o. r.	312950	312951
	NPT ⅜	6.0	0.7	0...232	32 / 1.26	312952	o. r.	312953	312954
	Stainless steel body								
	NPT ¼	6.0	0.7	0...232	32 / 1.26	312955	o. r.	312956	312957
	NPT ½	12.0	2.5	0...232	42 / 1.65	312958	-	-	-

o. r. = on request
 - = not available
 1.) Maximum allowable working pressure

UL Listed

Note:

- Please note that the cable plug **Type 2509** ▶ is included. For more information on the cable plug, see “[Cable plug Type 2509, form A according to DIN EN 175301 - 803](#)” on page 25.
- Further versions with alternative voltages, G or RC internal thread, seal material EPDM/EPDM available on request.

Circuit function	Port connection	Orifice [mm]	C _v value water [gal/min]	Pressure range (MAWP ^{1.)} [psi]	Coil size [mm/inch]	Article no.			
						024/DC [V/Hz]	024/60 [V/Hz]	120/60 [V/Hz]	240/60 [V/Hz]
NPT internal thread, seal material FKM/FKM									
CF A 2/2-way solenoid valve Servo-controlled Normally closed 	Brass body								
	NPT ¼	6.0	0.7	0...232	32 / 1.26	312939	o. r.	312940	312941
	NPT ⅜	6.0	0.7	0...232	32 / 1.26	312942	o. r.	312943	312944
	Stainless steel body								
	NPT ¼	6.0	0.7	0...232	32 / 1.26	312945	o. r.	312946	312947
	NPT ½	12.0	2.5	0...232	42 / 1.65	312948	-	-	-

o. r. = on request
 - = not available
 1.) Maximum allowable working pressure

DTS 1000581100 EN Version: D Status: RL (released | freigegeben | valide) printed: 15.05.2024

8.5. Ordering chart standard version up to 363 psi

UL Recognized

Note:

- Please note that the cable plug **Type 2518** ▶ is included. Further versions are available on request. For more information on the cable plug, see [“Cable plug Type 2518, form A according to DIN EN 175301 - 803” on page 25.](#)
- Further versions with alternative voltages, G or RC internal thread, seal material PTFE/EPDM available on request.

Circuit function	Port connection	Orifice [mm]	C _v value water [gal/min]	Pressure range (MAWP ^{1.)})		Coil size [mm/inch]	Article no.			
				Liquids [psi]	Gases [psi]		024/DC [V/Hz]	024/60 [V/Hz]	120/60 [V/Hz]	240/60 [V/Hz]
NPT internal thread, seal material PTFE/FKM										
CF A 2/2-way solenoid valve Servo-controlled Normally closed 	Brass body									
	NPT ¼	6.0	0.7	0...363	0...363	40 / 1.57	312960 𠄎	o. r.	312961 𠄎	312962 𠄎
	NPT ⅜	6.0	0.7	0...363	0...363	40 / 1.57	312963 𠄎	o. r.	312964 𠄎	312965 𠄎
	Stainless steel body									
	NPT ¼	6.0	0.7	0...363	0...363	40 / 1.57	o. r.	o. r.	o. r.	o. r.
	NPT ⅜	6.0	0.7	0...363	0...363	40 / 1.57	o. r.	o. r.	o. r.	o. r.
	NPT ½	12.0	2.5	0...363	0...363	42 / 1.65	468776 𠄎	-	-	-

o. r. = on request
 - = not available
 1.) Maximum allowable working pressure

UL Listed

Note:

- Please note that the cable plug **Type 2509** ▶ is included. For more information on the cable plug, see [“Cable plug Type 2509, form A according to DIN EN 175301 - 803” on page 25.](#)
- Further versions with alternative voltages, G or RC internal thread, seal material PTFE/EPDM available on request.

Circuit function	Port connection	Orifice [mm]	C _v value water [gal/min]	Pressure range (MAWP ^{1.)})		Coil size [mm/inch]	Article no.			
				Liquids [psi]	Gases [psi]		024/DC [V/Hz]	024/60 [V/Hz]	120/60 [V/Hz]	240/60 [V/Hz]
NPT internal thread, seal material PTFE/FKM										
CF A 2/2-way solenoid valve Servo-controlled Normally closed 	Brass body									
	NPT ¼	6.0	0.7	0...363	0...363	40 / 1.57	o. r.	o. r.	o. r.	o. r.
	NPT ⅜	6.0	0.7	0...363	0...363	40 / 1.57	o. r.	o. r.	o. r.	o. r.
	Stainless steel body									
	NPT ¼	6.0	0.7	0...363	0...363	40 / 1.57	297185 𠄎	o. r.	o. r.	o. r.
	NPT ⅜	6.0	0.7	0...363	0...363	40 / 1.57	20016846 𠄎	o. r.	o. r.	o. r.
	NPT ½	12.0	2.5	0...232	0...232	42 / 1.65	o. r.	-	-	-

o. r. = on request
 - = not available
 1.) Maximum allowable working pressure

DTS 1000581100 EN Version: D Status: RL (released | freigegeben | valide) printed: 15.05.2024

8.6. Ordering chart high pressure version DN 6 – pressure ranges up to 2321 psi (PN16) with coil UL Recognized (cURus)

Note:

- The Kick and Drop coil (AC/DC) features integrated electronics for short-term power increase and decrease in double coil technology.
- Please note that only the electrical component as in the solenoid coil is UL Recognized.
- Further versions with alternative voltages, G or RC internal thread, seal materials are available on request.
- For the following table applies: Orifice 6.0 and C_v value water [gal/min] 0.87.
- Due to the wear-resistant PCTFE seat seals, a seat tightness of <2 cm³/min (air 68 °F) is guaranteed from a differential pressure of 290 psi or higher.

Circuit function	Port connection	Pressure range (MAWP ^{1.)}			Coil size [mm/inch]	Article no.		
		Water	Oil	Air		024/DC	024/60	120/60
		[psi]	[psi]	[psi]		[V/Hz]	[V/Hz]	[V/Hz]
NPT internal thread, stainless steel body, seal material PCTFE/FKM, cable plug with integrated rectifier for AC included in delivery								
CF A 2/2-way solenoid valve Servo-controlled Normally closed 	NPT ¼	14...1450	14...1160	14...1450	42 / 1.65	o. r.	o. r.	o. r.
	NPT ⅜	14...1450	14...1160	14...1450	42 / 1.65	o. r.	o. r.	o. r.

o. r. = on request
 1.) Maximum allowable working pressure

8.7. Ordering chart high pressure version DN 6 – pressure ranges up to 3626 psi (PN25) with coil UL Recognized (cURus)

Note:

- The Kick and Drop coil (AC/DC) features integrated electronics for short-term power increase and decrease in double coil technology.
- Please note that only the electrical component as in the solenoid coil is UL Recognized.
- Further versions with alternative voltages, G or RC internal thread, seal materials are available on request.
- For the following table applies: Orifice 6.0 and C_v value water [gal/min] 0.87.
- Due to the wear-resistant PCTFE seat seals, a seat tightness of <2 cm³/min (air 68 °F) is guaranteed from a differential pressure of 290 psi or higher.

Circuit function	Port connection	Pressure range (MAWP ^{1.)}			Coil size [mm/inch]	Article no.		
		Water	Oil	Air		024/DC	024/AC/DC	120 /AC
		[psi]	[psi]	[psi]		[V/Hz]	[V/Hz]	[V/Hz]
NPT internal thread, stainless steel body, seal material PCTFE/FKM								
CF A 2/2-way solenoid valve Servo-controlled Normally closed 	NPT ¼	14...3336	14...2900	14...3626	65 / 2.56	o. r.	–	–
		14...3626	14...3626	14...3626	42 / 1.65	–	o. r.	o. r.
	NPT ⅜	14...3336	14...2900	14...3626	65 / 2.56	o. r.	–	–
		14...3626	14...3626	14...3626	42 / 1.65	–	o. r.	o. r.

o. r. = on request
 – = not available
 1.) Maximum allowable working pressure

DTS 1000581100 EN Version: D Status: RL (released | freigegeben | valide) printed: 15.05.2024

8.8. Ordering chart high pressure version DN 12 – pressure range up to 3626 psi (PN25) with coil UL Recognized (cURus)

Note:

- The Kick and Drop coil (AC/DC) features integrated electronics for short-term power increase and decrease in double coil technology.
- Further versions with alternative voltages, G or RC internal thread, seal materials are available on request.
- Please note that only the electrical component as in the solenoid coil is UL Recognized.
- For the following table applies: Orifice 12.0 and C_v value water [gal/min] 2.54.
- Due to the wear-resistant PCTFE seat seals, a seat tightness of <2 cm³/min (air 68 °F) is guaranteed from a differential pressure of 290 psi or higher.

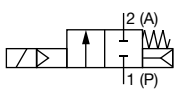
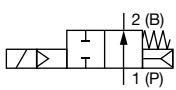
Circuit function	Port connection	Pressure range (MAWP ^{1.)} Standard			Article no.		Pressure range (MAWP ^{1.)} Kick and Drop			Article no.	
		Water	Oil	Air	024/DC	120/60	Water	Oil	Air	024/AC/DC	120/AC
		[psi]	[psi]	[psi]	[V/Hz]	[V/Hz]	[psi]	[psi]	[psi]	[V/Hz]	[V/Hz]
NPT internal thread, stainless steel body, seal material PCTFE/FKM, cable plug with integrated rectifier for AC included in delivery											
CF A 2/2-way solenoid valve Servo-controlled Normally closed 	NPT 1/2	14... 3626	14... 3626	14... 3626	o. r.	–	14... 3626	14... 3626	14... 3626	o. r.	o. r.
		14... 3626	14... 2900	14... 3626	–	o. r.					
CF B 2/2-way solenoid valve Servo-controlled Normally open 	NPT 1/2	14... 2900	14... 2176	14... 3626	o. r.	o. r.	14... 2900	14... 2176	14... 3626	o. r.	o. r.

o. r. = on request
 – = not available
 1.) Maximum allowable working pressure

8.9. Ordering chart version self-service car wash 1740 psi (PN16) – Type 8820 - 6240 with coil UL Recognized (cURus)

Note:

Further versions with alternative voltages, G or RC internal thread available on request.

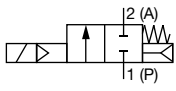
Circuit function	Port connection	Orifice single valve	C _v value water single valve	Pressure range (MAWP ^{1.)}	Coil size	Article no.	
		[mm]	[gal/min]	[psi]	[mm/inch]	024/DC	120/60
						[V/Hz]	[V/Hz]
Seal material PCTFE/FKM, cable plug with integrated rectifier for AC included in delivery							
CF A 2/2-way solenoid valve Servo-controlled Normally closed 	Stainless steel body						
	NPT 1/4	6.0	0.87	14...1740	42 / 1.65	o. r.	o. r.
	NPT 3/8	6.0	0.87	14...1740	42 / 1.65	o. r.	o. r.

o. r. = on request
 1.) Maximum allowable working pressure

DTS 1000581100 EN Version: D Status: RL (released | freigegeben | validé) printed: 15.05.2024

8.10. Ordering chart steam version DN 13 with coil UL Recognized (cURus)

Note:

Further versions with alternative voltages, G or RC internal thread available on request.

Circuit function	Port connection	Orifice [mm]	C _v value water [gal/min]	Pressure range steam (MAWP ^{1.)} [psi]	Coil size [mm/inch]	Article no. Kick and Drop coil	
						024/60 [V/Hz]	120/60 [V/Hz]
Seal material FKM/FKM							
CF A 2/2-way solenoid valve Servo-controlled Normally closed 	Brass body						
	NPT 1/2	13.0	3.82	0...58	42 / 1.65	o. r.	o. r.
	NPT 3/4	13.0	3.82	0...58	42 / 1.65	o. r.	o. r.
	Stainless steel body						
	NPT 1/2	13.0	3.82	0...58	42 / 1.65	o. r.	o. r.
	NPT 3/4	13.0	3.82	0...58	42 / 1.65	o. r.	o. r.

o. r. = on request

1.) Maximum allowable working pressure

8.11. Ordering chart coil UL Listed (cULus) for hazardous locations, Class I, Division 2

Standard version with cable coil

Note:

- The Kick and Drop coil (AC/DC) features integrated electronics for short-term power increase and decrease in double coil technology.
- Further versions with alternative voltages, G or RC internal thread, seal materials are available on request.
- With 3 m/9'10" cable as standard. Other lengths or version with terminal box on request.

Circuit function	Port connection	Orifice [mm]	C _v value water [gal/min]	Pressure range (MAWP ^{1.)} [psi]	Coil size [mm/inch]	Article no.	
						024/AC/DC [V/Hz]	120/AC [V/Hz]
NPT internal thread, seal material FKM/FKM							
CF A 2/2-way solenoid valve Servo-controlled Normally closed 	Brass body						
	NPT 1/4	6.0	0.7	0...232	40 / 1.57	o. r.	o. r.
	NPT 3/8	6.0	0.7	0...232	40 / 1.57	o. r.	20030584 𐀀
	Stainless steel body						
	NPT 1/4	6.0	0.7	0...232	40 / 1.57	20019107 𐀀	o. r.
	NPT 3/8	6.0	0.7	0...232	40 / 1.57	o. r.	20030802 𐀀
	NPT 1/2	12.0	2.5	0...145	42 / 1.65	o. r.	o. r.
	NPT 1/2	12.0	2.5	0...363	42 / 1.65 (Kick and Drop)	o. r.	o. r.

o. r. = on request

1.) Maximum allowable working pressure

DTS 1000581100 EN Version: D Status: RL (released | freigegeben | valide) printed: 15.05.2024

High pressure version up to 3626 psi (PN25) or 2321 psi (PN16) with cable coil

Note:

- The Kick and Drop coil (AC/DC) features integrated electronics for short-term power increase and decrease in double coil technology.
- Further versions with alternative voltages, G or RC internal thread, seal material EPDM/EPDM available on request.
- With 3 m/9'10" cable as standard. Other lengths or version with terminal box on request.

Circuit function	Port connection	Orifice [mm]	C _v value water [gal/min]	Pressure range (MAWP ^{1.)}			Coil size [mm/inch]	Article no.	
				Water	Oil	Air		024/AC/DC	120/AC
				[psi]	[psi]	[psi]		[V/Hz]	[V/Hz]
NPT internal thread, stainless steel body, seal material PCTFE/FKM or PCTFE/PEEK									
CF A									
2/2-way solenoid valve Servo-controlled Normally closed									
Pressure rating up to 2321 psi									
	NPT ¼	6.0	0.7	14...2321	14...1740	14...2321	42 / 1.65 (Kick and Drop)	20040448	o. r.
	NPT ¾	6.0	0.7	14...2321	14...1740	14...2321	42 / 1.65 (Kick and Drop)	o. r.	o. r.
Pressure rating up to 3626 psi									
	NPT ½	12.0	2.5	14...2900	14...2176	14...3626	42	o. r.	o. r.
	NPT ½	12.0	2.5	14...3626	14...3626	14...3626	42 (Kick and Drop)	20005146	o. r.
	NPT ½	12.0	2.5	14...2900	14...2176	14...3626	42 (Kick and Drop)	20024491	o. r.
CF B									
2/2-way solenoid valve Servo-controlled Normally open									

o. r. = on request
1.) Maximum allowable working pressure

Further versions on request	
Approval Further information can be found in chapter "3. Approvals and conformities" on page 5.	Material Seal: EPDM
Process connection <ul style="list-style-type: none"> • Flange • Cartridge • Manifold 	Voltage 042/50, further voltages on request

DTS 1000581100 EN Version: D Status: RL (released | freigegeben | valide) printed: 15.05.2024

8.12. Ordering chart accessories

Cable plug Type 2518, form A according to DIN EN 175301 - 803

Note:

- Dimensions in mm
- For further versions see data sheet **Type 2518** ▶.

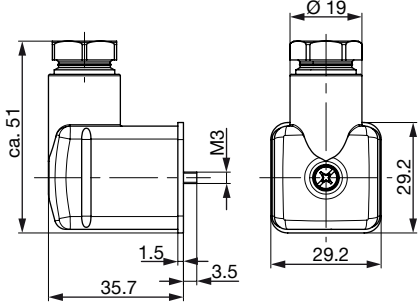
Cable plug	Dimensions	Version	Voltage	Article no.
		Without circuitry (AC/DC)	0...250 V AC/DC	314802
		With LED (AC/DC)	12...24 V AC/DC	314812
		With LED and varistor (AC/DC)	12...24 V AC/DC	314820
		With rectifier, LED and varistor	12...24 V AC/DC	314816
		Without circuitry (AC/DC) with silicone seal for higher ambient temperature, e.g. steam version (NA07)	0...250 V AC/DC	361687

Cable plug Type 2509, form A according to DIN EN 175301 - 803

Note:

- Dimensions in mm
- Without circuitry (standard)
- The cable plug meets the requirements for UL hazloc Div. 2.
- The cable plug Type 2509 meets the requirements in accordance with UL Listed (UL 429) in assembly with a Bürkert solenoid valve.
- Refer to data sheet **Type 2509** ▶ for more information about the cable plug.

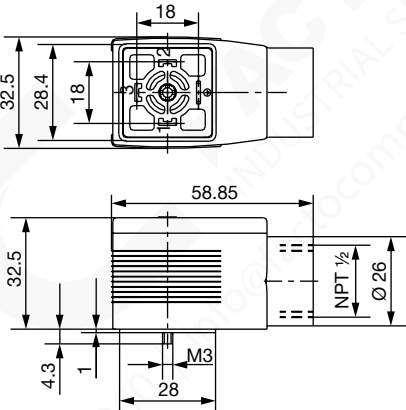
Cable plug	Dimensions	Version	Voltage	Article no.
		Without circuitry	0...250 V AC/DC	137943

Special tool to turn the terminal box

Note:

This special tool is not supplied with the valve.



Description	Components of the set	Article no.
Set SC02-AC10 	<ul style="list-style-type: none"> • Special wrench • Service manual 	293488

DTS 1000581100 EN Version: D Status: RL (released | freigegeben | validé) printed: 15.05.2024

Mounting bracket

Note:

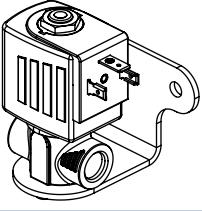
- The mounting bracket, two cylinder screws M4x8 and two spring rings are included in the scope of delivery.
- The mounting bracket can be used for all standard and high-pressure versions DN 6 PN16 up to 2321 psi including HazLoc option.
- The mounting bracket cannot be used for the DN 13 version and high-pressure versions PN25 up to to 3626 psi as well as various special bodies made of solid material.

Description	Article no.
Mounting bracket for Type 6020/6027/6240/6440 	282304 

DTS 1000581100 EN Version: D Status: RL (released | freigegeben | validé) printed: 15.05.2024

FACTOCOMPONENTS
 INDUSTRIAL SUPPLIES AND MANUFACTURING EQUIPMENT
 02-384-6060 | info@factocomponents.co.th | www.factocomponents.co.th