



ALVT

Vortex Flowmeter

Model ALVT Series



GENERAL

Vortex flow sensing technology relies on measuring the number of vortex pulses generated, by a bluff body immersed in the flow stream. The vortex meter uses dual sensor technology, producing two independent vortex signals, which allows for signal amplification and common mode noise reduction. Our sensors never touch the process fluid; the crystal sensors are bonded behind a stainless steel wall. The electronics pick up the slightest pressure pulsations generated by the vortices through the stainless steel wall. This design allows meters to have an extremely wide turndown while maintaining an almost unlimited upper end and a high pressure rating. Our sensor is the thinnest wafer vortex on the market. The meter body bolt lengths are shorter to allow for better flange alignment and tighter, leak-free installations.

FEATURES

- Suitable for a wide variety of applications with steam, gas, and liquid medias
- No moving parts and no leak paths; no o-ring or graph oil seals to wear, fail or leak
- Two independent sensors, allowing for better signal amplification and noise reduction
- Error messages displayed for or erratic flows and flows outside of calibrated ranges
- Field calibration possible with integral or remote electronics and keypad
- True 2-wire 4-20 mA interface
- Wide measuring range, turn-down ratio of 10:1
- Available as an integrated mass flow vortex meter
- Weather proof multi-pole connector for power, signal and serial interface
- Area of measurement can be smaller than pipe connection for better rangeability



SPECIFICATION

• Process Connections:	wafer, flanged	• Housing protection:	IP65; IP67
• Process temperature:	-40 ~+660°F (-40~+350°C)	• Ex-protection:	exid II B T4; exib II C T 4
• Pressure:	232 psi (1.6MPa) -std; Opt: up to 2175 psi; (15Mpa)	• Cable:	Standard 5m for remote version
• Velocity Range:		• weight (approximate):	Wafer: 10 ~ 13kg to DN300 Flange: flange weight contact factory
	Liquids: 0.6~6 m/s	• Signal Interface:	RS485, HART
	Gas & Steam: 0.6~40 m/s	• Engine units:	m ³ /hr, kg/hr, ton/hr
• Accuracy	±1.0% RD @Liquids ±1.5% RD @Gas & Steam	• Keypad:	Rate, total
• Repeatability:	0.33% for liquid, 0.5% for gas/steam	• Power supply:	Isolated 13.5~45 V _{DC}
• Turn down ratio	Up to 10:1	• NIST traceable:	YES
• Material:	SS# 304 -std, SS# 316 -opt	• Data storage:	EPROM storage up to 5 years
• Signal output:	Pulse output, 2-wire 4~20mA _{DC}	• Data logger:	Flow & total, sampling Times 0.5 S
• RAM Back-up	Lithium battery, 3.6V _{DC}		

■ Flange-ANSI 150#

Nom. Diameter inches (mm)	L ± 3 (mm)	H ± 3 (mm)	Weight (kg)
½" (15)	200	323	9
¾" (20)	200	323	9
1" (25)	200	323	10
1 ¼" (32)	200	317	12
1 ½" (40)	200	322	14
2" (50)	200	326	18
2 ½" (65)	200	334	21
3" (80)	200	340	24
4" (100)	250	350	29
5" (125)	250	366	34
6" (150)	300	375	52
8" (200)	350	406	60
10" (250)	450	431	72
12" (300)	500	456	87

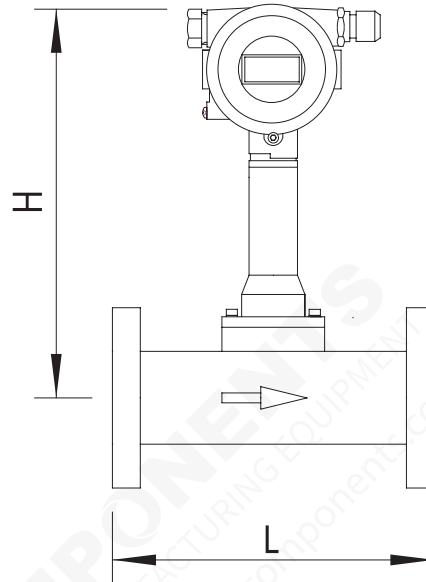

■ Wafer

Nom. Diameter inches (mm)	L ± 3 (mm)	H ± 3 (mm)	Weight (kg)
½" (15)	65	350	9
¾" (20)	65	350	9
1" (25)	65	350	10
1 ¼" (32)	65	357	12
1 ½" (40)	65	357	14
2" (50)	65	367	18
2 ½" (65)	65	387	21
3" (80)	65	397	24
4" (100)	65	417	29
5" (125)	65	440	34
6" (150)	65	465	52
8" (200)	85	515	60
10" (250)	100	565	72
12" (300)	120	615	87

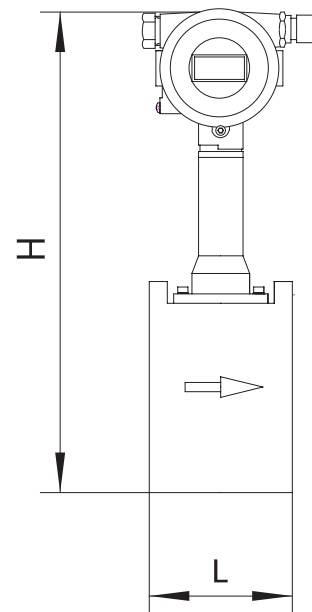

■ Mass flow of saturated steam (kg/hr)

Pressure	0.2Mpa		0.3Mpa		0.4Mpa		0.6Mpa		0.7Mpa		0.81Mpa		1Mpa		1.2Mpa		1.5Mpa	
Temp	121°C		134°C		144°C		159°C		165°C		171°C		180°C		188°C		199°C	
Density	1.155Kg/m ³		1.672Kg/m ³		2.185Kg/m ³		3.182Kg/m ³		3.671Kg/m ³		4.218Kg/m ³		5.160Kg/m ³		6.132Kg/m ³		7.706Kg/m ³	
DN15	9	44	13	64	17	83	24	121	28	140	32	161	39	197	47	234	59	294
DN20	16	78	23	113	30	148	43	216	50	249	57	286	70	350	83	416	104	522
DN25	24	122	35	177	46	231	67	337	78	389	89	447	109	547	130	650	163	816
DN32	40	200	58	290	76	379	110	552	127	637	146	732	179	896	213	1064	267	1337
DN40	31	313	45	453	59	593	86	863	100	996	114	1144	140	1399	166	1663	209	2090
DN50	49	489	71	708	93	926	135	1348	156	1556	179	1787	219	2186	260	2598	327	3265
DN65	83	827	120	1197	156	1565	228	2279	263	2629	302	3021	370	3695	439	4391	552	5518
DN80	125	1253	181	1814	237	2370	345	3452	398	3982	458	4575	560	5597	665	6652	836	8359
DN100	196	1958	283	2834	370	3703	539	5393	622	6222	715	7149	875	8746	1039	10393	1306	13061
DN125	306	3059	443	4428	579	5787	843	8427	972	9722	1117	11171	1367	13665	1624	16239	2041	20408
DN150	440	4405	638	6376	833	8333	1213	12135	1400	14000	1609	16086	1968	19678	2338	23385	2939	29387
DN200	783	7831	1134	11336	1481	14814	2157	21573	2489	24888	2860	28597	3498	34983	4157	41573	5224	52244
DN250	1224	12235	1771	17712	2315	23146	3371	33708	3889	38888	4468	44682	5466	54661	6496	64958	8163	81631
DN300	1762	17619	2551	25505	3333	33331	4854	48539	5600	55998	6434	64342	7871	78712	9354	93539	11755	117549

*Note: The pressure in table is absolute pressure

■ Volumetric flow of gas (m³/hr)

ID inches (mm)	Flow range	Frequency- Hz
½" (15)	5-20	460-2500
¾" (20)	6-50	220-3400
1" (25)	8-60	180-2700
1¼" (32)	14-100	130-1400
1½" (40)	18-180	90-1550
2" (50)	30-480	80-1280
2½" (65)	50-500	60-900
3" (80)	70-700	40-700
4" (100)	100-1000	30-570
5" (125)	150-1500	23-490
6" (150)	200-2000	18-360
8" (200)	400-4000	13-325
10" (250)	600-6000	11-220
12" (300)	1000-10000	9-210

■ Volumetric flow of liquid (m³/hr)

ID inches (mm)	Flow range	Frequency- Hz
½" (15)	0.6-6	58-780
¾" (20)	1.2-8	40-600
1" (25)	2-16	35-400
1¼" (32)	2.2-20	20-250
1½" (40)	2.5-25	10-240
2" (50)	3.5-35	8-190
2½" (65)	6-60	7-150
3" (80)	13-130	6-110
4" (100)	20-200	5-90
5" (125)	30-300	4.5-76
6" (150)	50-500	3.8-60
8" (200)	100-1000	3.2-48
10" (250)	150-1500	2.5-37.5
12" (300)	200-2000	2.2-30.6

*Note: Standard condition 20°C, 0.1MPa (absolute pressure), or under atmosphere at 20°C

Please contact your local SmartMeasurement application engineer
You also need to provide the following information:

TYPE OF FLUID (LIQUID/GAS OR STEAM)	Please provide the name of your fluid, including operating density and viscosity
FULL SCALE FLOW	Maximum and minimum flow rates, units must be Kg/hr, Lb/hr, LPM or GPM
LINE SIZE	Please specify your pipe size as well connection type (flange, threaded)
PROCESS PRESSURE AND TEMPERATURE	We will calibrate your meter as close to your operating conditions as possible
TYPE OF ELECTRONICS	Please indicate if you want integral or remote electronics

ALVT SERIES														
EXAMPLE: ALVT-2-3-40-D-1-2-0-N-1-NNN														
ALVT II		**	**	**	**	**	**	**	**	**	**	**	**	DESCRIPTION
Flanged	1												Style	
Wafer	2													
Liquid	2												Fluid	
Gas	3													
Standard steam	4													
Inline type ½"~12" (DN15~DN300)		**												Line Size
Integral with digital display - standard			D											Display
Remote with 5m cable			R											
13.5~45 V _{DC} - Standard			1											Power Supply
3.6V lithium battery -no output			2											
13.5~45 V _{DC} + lithium battery			3											
No output			0											Signal Output
Pulse output			1											
Two wire 4-20mA _{DC} output			2											
No digital communication			0											Communication
RS-485 Communication without 4-20mA			3											
HART Communication @ over 4-20mA			5											
Standard -40~482 °F (-40 ~ 250°C)				N										Temperature
High Temp 382~660 °F (250 ~350°C)				H										
232 psi (1.6MPa)					1									Pressure
363 psi (2.5MPa)					2									
580 psi (4.0MPa)					3									
928 (6.4MPa)					4									
Other perssure: please contact factory														
None						N								Explosion Proof
Explosive Isolated						G								
Intrinsically safety						B								
Standard material - SS# 304							NN							Options
Special material - SS# 316							316							
Mass flow program							MS							
Mass flow program with build-in RTD							MT							
Flow computer - 24 V _{DC} power, 4-20mA output, LED display							FC							

