





### pH measuring system for hygienic applications

- Special glass-free probe for measuring pH to be connected to Type 8619 multiCELL
- Sterile design, CIP-compatible, in-line sterilizable
- Robust and unbreakable construction
- Long service life, long calibration intervals
- Especially suitable when preparing foods and drinks



Product variants described in the data sheet may differ from the product presentation and description.

#### Can be combined with

	<b>Type 8619</b> multiCELL - multi-channel/ multi-function transmitter/ controller	▶
	<b>Type 8200</b> Armatures for analysis sensors	▶

#### Type description

The Type 8201 pH measuring system is suitable for measuring absolute pH values in liquids between pH 0 and pH 12 at medium temperatures of up to 140°C and process pressures of max. 6 bar.

Due to its hygienic design and the robust glass-free construction, this model is particularly suitable for use in hygienic processes. An example would be the production of foods and active ingredients, during which the pH value of liquid mediums (including those which are viscous or contain solids) is measured.

The pH electrode's extremely smooth enamel surface prevents the medium from sticking and is very easy to clean in line. Due to its robust design and high temperature and chemical tolerance, the electrode stays in the process even during a CIP purification. This means that expensive retractable fittings can be dispensed with.



## Table of contents

<b>1. General technical data</b>	<b>3</b>
<b>2. Approvals and conformities</b>	<b>5</b>
2.1. General notes .....	5
2.2. Conformity .....	5
2.3. Standards .....	5
2.4. Pressure Equipment Directive (PED) .....	5
Device used on a pipe.....	5
Device used on a vessel.....	5
2.5. Foods and beverages/Hygiene .....	5
<b>3. Materials</b>	<b>6</b>
3.1. Bürkert resistApp .....	6
<b>4. Dimensions</b>	<b>6</b>
4.1. Enamel pH probe .....	6
Probe without adaptation.....	6
Probe with adaptation set PG 13.5 for pH armature Type 8200.....	7
Probe with adaptation set for fitting Type 8201, weld spigot.....	7
Probe with adaptation set for flange connection adapted for GEA Tuchenhagen VARINLINE process connection .....	8
Probe with adaptation set for clamp 2" external Ø 64 mm.....	8
4.2. Fittings Type 8201 .....	9
4.3. Electrolyte vessel.....	9
<b>5. Performance specifications</b>	<b>10</b>
5.1. Sensor corrosion resistance diagram .....	10
5.2. pH temperature diagram .....	10
<b>6. Product installation</b>	<b>10</b>
6.1. Installation notes.....	10
<b>7. Product operation</b>	<b>11</b>
7.1. Measuring principle .....	11
<b>8. Product accessories</b>	<b>11</b>
8.1. Ultrasonic electrolyte level switch .....	11
8.2. Maintenance sets .....	11
<b>9. Ordering information</b>	<b>12</b>
9.1. Bürkert eShop .....	12
9.2. Recommendation regarding product selection.....	12
9.3. Bürkert product filter .....	12
9.4. Bürkert Product Enquiry Form .....	13
9.5. Ordering chart .....	13
9.6. Ordering chart accessories.....	14

## 1. General technical data

The complete measuring system consists of the pH probe, an adaptation set, a fitting, the reservoir with hose for the electrolyte solution, the electrolyte solution and the electric cable for connecting to a suitable transmitter.

The pH probe Type 8201 is supplied without adaptation. According to the chosen fitting/armature the appropriate adaptation set has to be selected. Different hygienic fittings (Type 8201) or for general purpose applications pH armatures of Type 8200 can be selected.

See **data sheet Type 8200** ▶ for more information.

### Product properties

#### Material

Make sure the device materials are compatible with the fluid you are using.

Further information can be found in chapter **"3.1. Bürkert resistApp" on page 6**.

#### Wetted parts

Sensor tube	Enamelled steel tube
Process connection	Stainless steel 1.4404
Electrode head	PVDF
Diaphragm	Ceramic
Seal	EPDM
Electrolyte vessel	Stainless steel (1.4301)
Compatibility	Any tanks or process pipelines which are fitted with <ul style="list-style-type: none"> <li>• pH armature Type 8200 or</li> <li>• Fitting Type 8201 or</li> <li>• Flange connection adapted for GEA Tuchenhagen VARINLINE process connection (DN 50... DN 125) or</li> <li>• Clamp 2"</li> </ul> See <b>data sheet Type 8200</b> ▶ or chapter <b>"4.2. Fittings Type 8201" on page 9</b> or chapter <b>"9.5. Ordering chart" on page 13</b> for more information.
Dimensions	Further information can be found in chapter <b>"4. Dimensions" on page 6</b> .
Temperature sensor	Pt1000 integrated within the holder
Measuring variable	Absolute pH value
Reference system	<ul style="list-style-type: none"> <li>• Aseptic ground (ceramic) diaphragm</li> <li>• Reference electrode Ag/AgCl</li> <li>• KCl electrolyte 3-molar sterile (conform to FDA)</li> </ul>
Measuring range	0...10 pH (for up to 12 pH, see chapter <b>"5.2. pH temperature diagram" on page 10</b> .)
Measuring chain zero point	8.65 ± 1 pH <sup>1)</sup>
Measuring chain isotherm point pH <sub>0</sub>	1.0 ± 1 pH; U <sub>is</sub> = 440 mV <sup>1)</sup>

#### Product accessory

Suitable transmitter <sup>2)</sup>	<ul style="list-style-type: none"> <li>• Multi channel and multi function multiCELL transmitter/controller Type 8619 See <b>data sheet Type 8619 multiCELL</b> ▶ for more information.</li> <li>• The transmitter intended for use must meet the following requirements:           <ul style="list-style-type: none"> <li>– symmetrically high-ohm signal input with <math>R_i \geq 10^{12} \Omega</math></li> <li>– analogue output for current standard signal (0...20 mA, 4...20 mA)</li> <li>– zero point and isotherm point adjustable separately</li> </ul> </li> </ul>
------------------------------------	---

#### Performance data

Measuring deviation	Max. ± 0.05 pH, depending on calibration
Repeatability	0.05 pH
Slope of measuring chain	56...59 mV/pH <sup>1)</sup> at 25 °C (77 °F)
Measurement chain potential	+ 600...- 400 mV
Inner resistance of measuring chain	10 <sup>9</sup> ...10 <sup>10</sup> Ω at + 25 °C (77 °F)
Diaphragm resistance	Approx. 20...200 kΩ
Insulation resistance	≥ 10 <sup>12</sup> Ω
Inner capacity (with connection cable)	≤ 5 nF
Inner inductivity (with connection cable)	Negligibly low
Thermal shock resistance	ΔT = 120 °C (248 °F)
Corrosion resistance	Further information can be found in chapter <b>"5.1. Sensor corrosion resistance diagram" on page 10</b> .

## Type 8201

### Electrical data

Output	<ul style="list-style-type: none"> <li>pH value: analog signal, to be connected to multiCELL transmitter/controller Type 8619. See <b>data sheet Type 8619 multiCELL</b> ▶ for more information.</li> <li>Pt1000: 2-wire</li> </ul>
Recommended connection cable	<p>Max. 5 m length (cable lengths of more than 5 m may adversely affect the response behavior of the Type 8201 probe).</p> <ul style="list-style-type: none"> <li>Cable designed for transmission of very high-impedance signals from the probe to the transmitter. A 220 nF capacitor has to be fit to the stripped cable end which is connected in series with the wire designed for the cable shield.</li> <li>Prefabricated cable to transmit all electric signals and functions from the probe to the transmitter, see chapter <b>"9.5. Ordering chart"</b> on page 13.</li> </ul>

### Medium data

Fluid conductivity	Min. 1 µS/cm
Fluid temperature	0...+ 140 °C (+ 32...+ 284 °F) Further information can be found in chapter <b>"5.2. pH temperature diagram"</b> on page 10.
Fluid pressure	- 1...+ 6 bar rel. (- 14...+ 87 PSI)

### Process/Pipe connection & communication

Process connection	<p>Through adaptation sets for</p> <ul style="list-style-type: none"> <li>pH armature Type 8200 in stainless steel</li> <li>Hygienic fittings Type 8201           <ul style="list-style-type: none"> <li>Weld connection DN 25 (Ingold welding nozzle)</li> <li>Weld connection DN 30, other on request</li> <li>Stainless steel connecting pieces 1.4404</li> </ul> </li> <li>Flange connection adapted for GEA Tuchenhausen VARINLINE process connection (DN 50... DN 125)</li> <li>Clamp 2"</li> </ul> <p>See <b>data sheet Type 8200</b> ▶ or chapter <b>"4.1. Enamel pH probe"</b> on page 6 or chapter <b>"9.5. Ordering chart"</b> on page 13 for more information.</p>
Electrical connection	6-pin gold-plated Variopin connector

### Approvals and conformities

#### Directives

CE directive	Further information on the CE directive can be found in chapter <b>"2.3. Standards"</b> on page 5.
Pressure equipment directive	Complying with article 4, paragraph 1 of 2014/68/EU directive Detailed information on the pressure equipment directive can be found in chapter <b>"2.4. Pressure Equipment Directive (PED)"</b> on page 5.
Foods and beverages/Hygiene	<ul style="list-style-type: none"> <li>FDA declaration of conformity</li> <li>ECR1935/2004 declaration</li> </ul>

### Environment and installation

Ambient temperature	Operation and storage: 0...+ 50 °C (+ 32...+ 122 °F)
Relative air humidity	≤ 85 %, without condensation
Height above sea level	Max. 2000 m
Operating condition	Continuous
Equipment mobility	Fixed
Application range	Indoor and outdoor Protect the device against electromagnetic interference, ultraviolet rays and, when installed outdoors, against the effects of climatic conditions.
Degree of protection according to IEC/ EN 60529	IP68
Installation category	Category I according to UL/EN 61010-1
Pollution degree	Degree 2 according to UL/EN 61010-1

1.) See probe test report for exact values

2.) The probe-specific characteristics, such as slope, zero point and isotherm point, as well as the user-specific settings must be entered in the transmitter (parameterized) before calibration can be carried out. The characteristic values are indicated in the probe test report. For programming the transmitters, refer to the manufacturers' operating instructions.

## Type 8201

## 2. Approvals and conformities

### 2.1. General notes

- The approvals and conformities listed below must be stated when making enquiries. This is the only way to ensure that the product complies with all required specifications.
- Not all available variants of the device can be supplied with the below mentioned approvals or conformities.

### 2.2. Conformity

In accordance with the Declaration of Conformity, the product is compliant with the EU Directives.

### 2.3. Standards

The applied standards which are used to demonstrate compliance with the EU Directives are listed in the EU-Type Examination Certificate and/or the EU Declaration of Conformity.

### 2.4. Pressure Equipment Directive (PED)

The device conforms to article 4, paragraph 1 of the Pressure Equipment Directive (PED) 2014/68/EU under the following conditions:

#### Device used on a pipe

##### Note:

- The data in the table is independent of the chemical compatibility of the material and the fluid.
- PS = maximum admissible pressure (in bar), DN = nominal diameter of the pipe

Type of fluid	Conditions
Fluid group 1, article 4, paragraph 1.c.i	DN ≤ 25
Fluid group 2, article 4, paragraph 1.c.i	DN ≤ 32 or PS*DN ≤ 1000
Fluid group 1, article 4, paragraph 1.c.ii	DN ≤ 25 or PS*DN ≤ 2000
Fluid group 2, article 4, paragraph 1.c.ii	DN ≤ 200 or PS ≤ 10 or PS*DN ≤ 5000

#### Device used on a vessel

##### Note:

- The data in the table is independent of the chemical compatibility of the material and the fluid.
- PS = maximum admissible pressure (in bar), V = vessel volume

Type of fluid	Conditions
Fluid group 1, article 4, paragraph 1.a.i	V > 1 L and PS*V ≤ 25 bar.L or PS ≤ 200 bar
Fluid group 2, article 4, paragraph 1.a.i	V > 1 L and PS*V ≤ 50 bar.L or PS ≤ 1000 bar
Fluid group 1, article 4, paragraph 1.a.ii	V > 1 L and PS*V ≤ 200 bar.L or PS ≤ 500 bar
Fluid group 2, article 4, paragraph 1.a.ii	PS > 10 bar and PS*V ≤ 10000 bar.L or PS ≤ 1000 bar

### 2.5. Foods and beverages/Hygiene

Conformity	Description
FDA	<b>FDA – Code of Federal Regulations</b> The KCl electrolyte complies in its composition with the Code of Federal Regulations published by the FDA (Food and Drug Administration, USA) according to the manufacturer's declaration.
	<b>EC Regulation 1935/2004 of the European Parliament and of the Council</b> The device complies in its composition with EC Regulation 1935/2004 according to the manufacturer's declaration.

### 3. Materials

#### 3.1. Bürkert resistApp



#### Bürkert resistApp – Chemical resistance chart

You want to ensure the reliability and durability of the materials in your individual application case? Verify your combination of media and materials on our website or in our resistApp.

[Start chemical resistance check](#)

### 4. Dimensions

#### 4.1. Enamel pH probe

##### Probe without adaptation

**Note:**

Dimensions in mm, unless otherwise stated

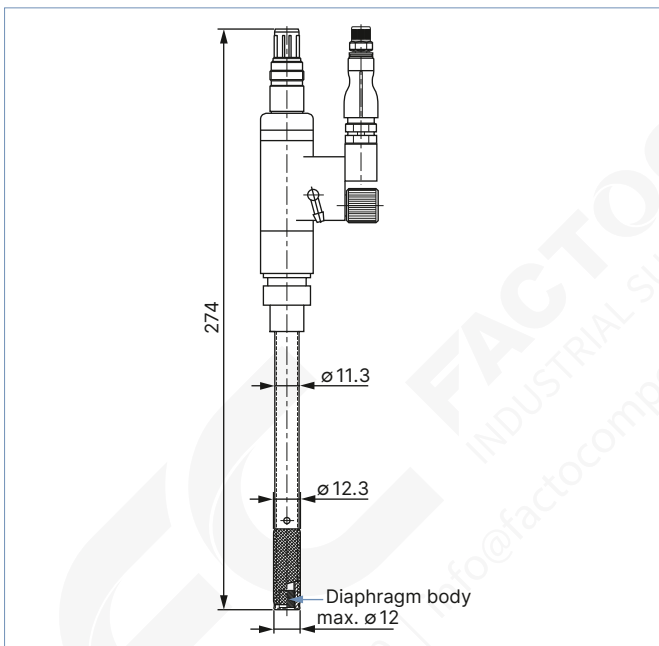

FACTOCOMPONENTS  
INDUSTRIAL SUPPLIES AND MANUFACTURING EQUIPMENT  
02-384-6060 | info@factocomponents.co.th | www.factocomponents.co.th

**Type 8201**

**Probe with adaptation set PG 13.5 for pH armature Type 8200**

**Note:**

Dimensions in mm, unless otherwise stated

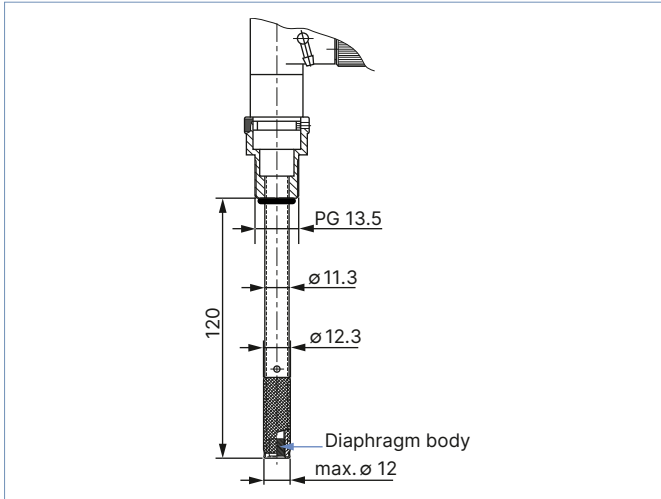

**Probe with adaptation set for fitting Type 8201, weld spigot**

**Note:**

- Dimensions in mm, unless otherwise stated
- Fitting Type 8201, see chapter "9.5. Ordering chart" on page 13.

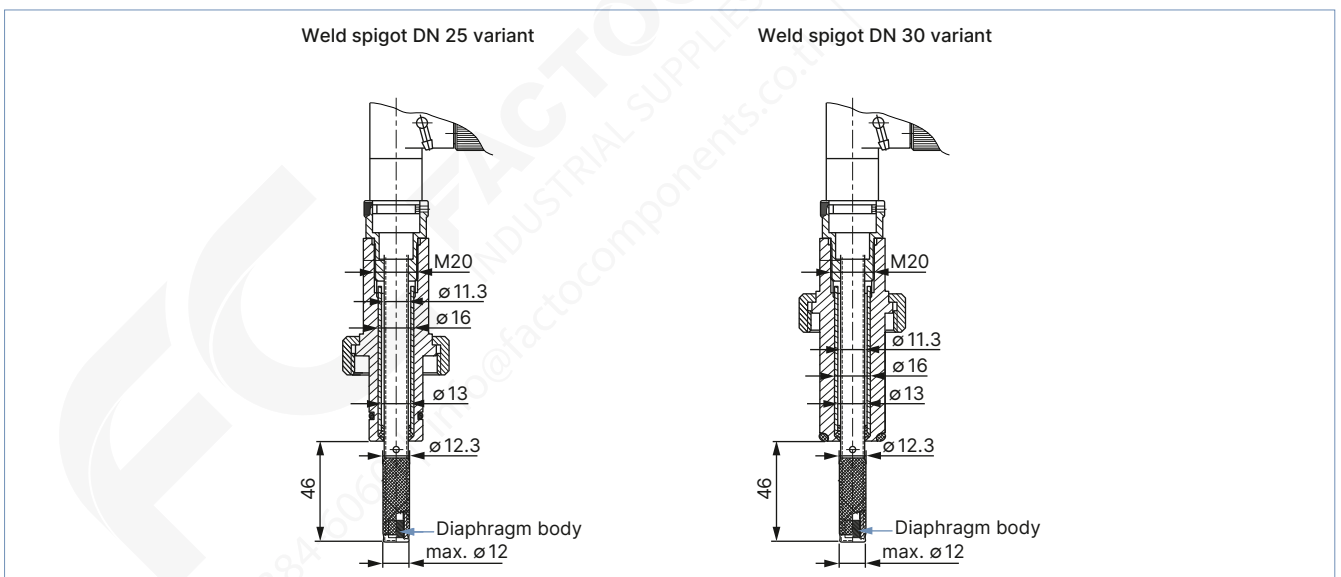

DTS 1000075647 EN Version: Y Status: RL (released | freigegeben | validé) printed: 26.08.2024

**Type 8201**

**Probe with adaptation set for flange connection adapted for GEA Tuchenhagen VARINLINE process connection**

**Note:**

- Dimensions in mm, unless otherwise stated
- Process connection DN 50...DN 125
- Analysis measurement chamber and O-ring  $\varnothing 60$  are not included in the scope of delivery.

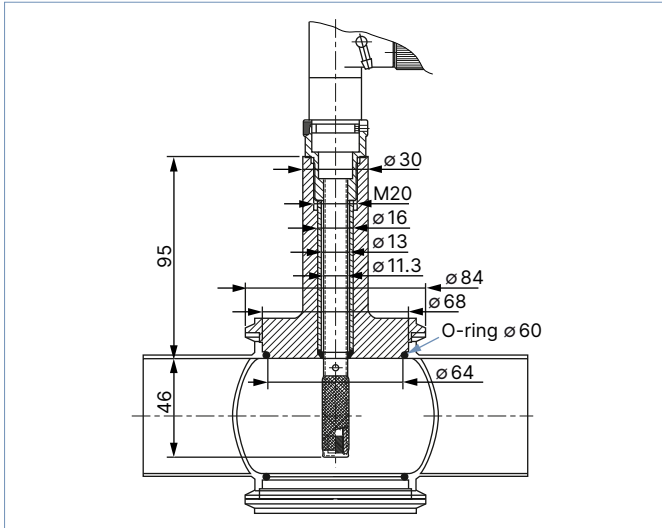

**Probe with adaptation set for clamp 2" external  $\varnothing 64$  mm**

**Note:**

Dimensions in mm, unless otherwise stated

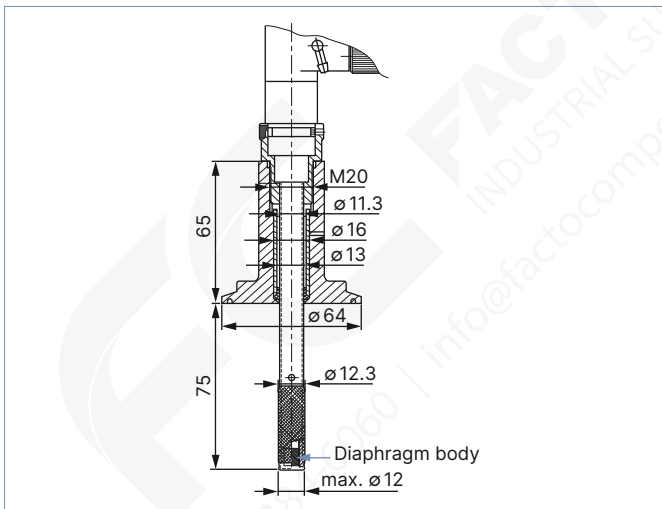



### 4.2. Fittings Type 8201

**Note:**

Dimensions in mm, unless otherwise stated

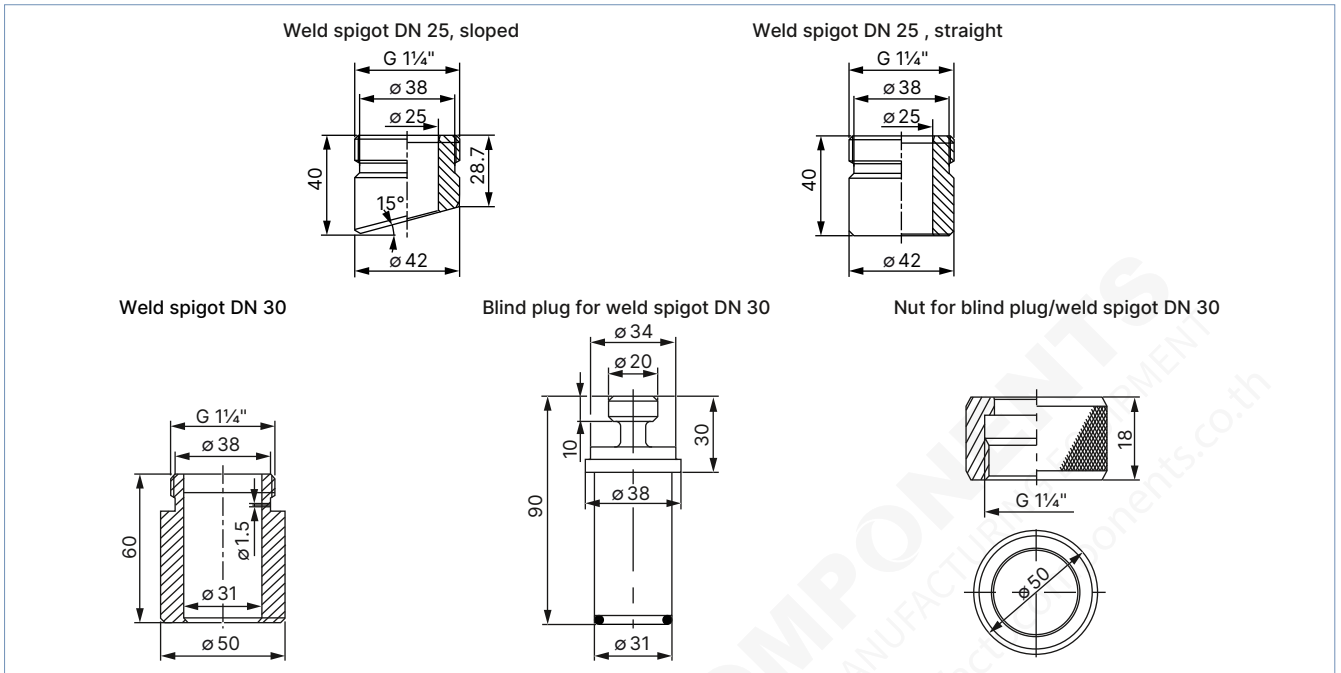

### 4.3. Electrolyte vessel

**Note:**

- Dimensions in mm, unless otherwise stated
- With built-in electrolyte supply bottle

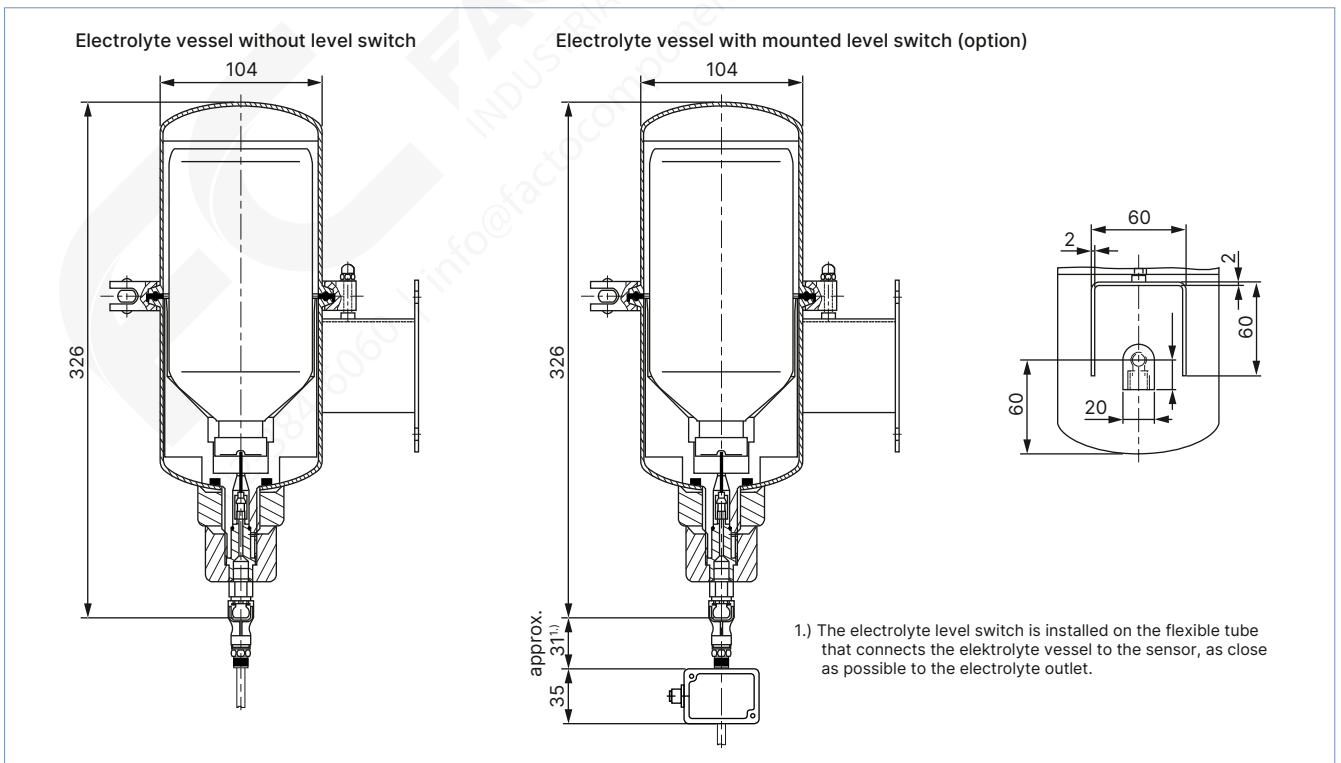

DTS 1000075647 EN Version: Y Status: RL (released | freigegeben | validé) printed: 26.08.2024

**Type 8201**

**5. Performance specifications**

**5.1. Sensor corrosion resistance diagram**

**Note:**

A corrosive attack of under 0.1 mm/year is deemed resistant.



**5.2. pH temperature diagram**

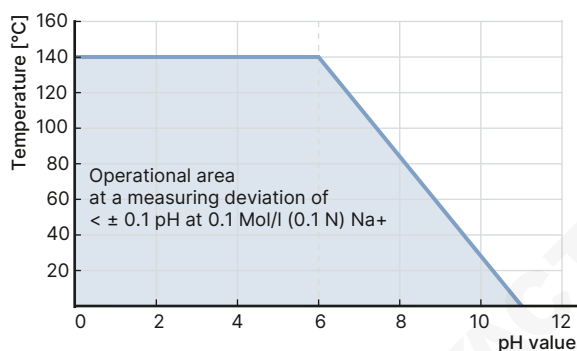

**6. Product installation**

**6.1. Installation notes**

The installation is limited to the following steps:

- proper installation (welding) of the fitting
- installation of the probe with the appropriate adapter set into the process
- mounting the pressure vessel (electrolyte connection vertically downwards) near the measuring point
- tubing the pH sensor and pressure vessel with the enclosed hose connection.

The electrolyte supply bottle is inserted into the pressure vessel and the pH sensor is filled with electrolyte by opening the bleed screw.

The assembly position of the pH sensor can be chosen freely. However, for proper operation, the effective surface of the sensor (approx. 10 cm<sup>2</sup>) must be completely immersed in the fluid (approx. 45 mm from the bottom edge of the sensor). The rhodium electrode located above the pH measurement enamel must always be in contact with the fluid.

The flow velocity should not exceed 3...4 m/s. Dry-storage of the pH sensor is unrestricted.

Sensor design	No.	Element
	1	Sensor tube, enamelled
	2	Pt1000 (integrated in the sensor tube)
	3	Rhodium electrode
	4	pH measurement enamel
	5	Diaphragm
	6	Bottom edge of the sensor

The sensor is connected to the transmitter using the connection cable for the enamelled pH probe, see chapter "9.5. Ordering chart" on page 13. The optional level sensor is connected to a suitable device (e.g. an alarm) to process this signal, see chapter "8.1. Ultrasonic electrolyte level switch" on page 11 for more information.

DTS 1000075647 EN Version: Y Status: RL (released | freigegeben | validé) printed: 26.08.2024

## Type 8201

## 7. Product operation

### 7.1. Measuring principle

The pH sensor works as a single-rod measuring cell. The measuring electrode and reference electrode are combined in one element. An enamelled steel pipe is used as the basic carrier. The measuring electrode is created by additionally attaching an ion-sensitive enamel layer (yellow) with metallic voltage conductor (positioned in the non-conductive blue enamel carrier layer). An ion exchange of H<sup>+</sup> ions and alkali ions takes place on the surface (gel layer) of this enamel layer. The Ag/AgCl reference electrode is located in the interior of the enamel pipe filled with electrolyte. A ceramic machined diaphragm is pressed into the lower end of the pipe. Electrolytic conduction takes place through the contact of the electrolyte via the annular gap of the diaphragm to the measuring solution. A Pt1000 for temperature compensation is also integrated in the sensor. The electrolyte (conform to FDA) used is 3-molar KCl, stored in a separate electrolyte vessel and permanently connected to the probe via a hose.

The pressure of the electrolyte vessel must be maintained above the process pressure by means of a Bürkert Type TPM001 pressure controller (not supplied, see [data sheet Type TPM001](#) ▶ for more information) or another one available on the market. We recommend a pressure difference of at least 0.5 bar. Under these conditions, the electrolyte flow rate is about 0.01 ml/h (actual flow rate specified in the test report delivered with the device). For non-pressurised processes the static overpressure of the pressure vessel mounted approx. 0.5 m above the probe is generally sufficient (50 mbar). Due to the extremely low permanent electrolyte flow through the very small annular gap, contamination of the reference electrode is practically excluded. Accidental operation without electrolyte is prevented by optional inductive level monitoring of the pressure container. When a minimum level has been reached, the electrolyte supply bottle in the pressure container is simply changed.

Bürkert Transmitter/Controller Type 8619 provides the analysis of the measured value. The maximum length of cable (5 m) between probe and converter (transmitter) has to be respected. pH probe Type 8201 is supplied without adaptation. The appropriate set is selected according to the fitting/armature chosen. Different hygienic variations of Type 8201 are available. Various standard armatures Type 8200 can be used as well.

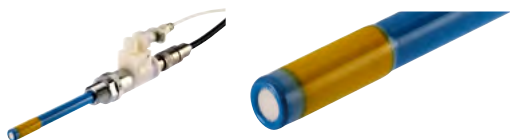

## 8. Product accessories

### 8.1. Ultrasonic electrolyte level switch

The use of a level switch allows the monitoring of the filling level of the electrolyte pressure vessel.

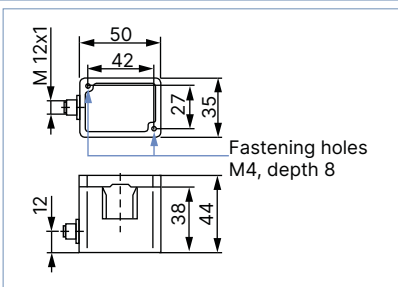
Accessory	Description	Dimensions
	<p><b>Ultrasonic electrolyte level switch</b></p> <ul style="list-style-type: none"> <li>• Body and cover in POM, ultrasonic cell in PPMA, seal in FKM, plug housing in PUR</li> <li>• Male fixed connector M12×1, 5-pin</li> <li>• 10...35 V DC, PNP open collector</li> <li>• A 5 meter long cable fitted with a right-angled 5-pin M12 female connector is included in the scope of delivery of this switch.</li> </ul> <p>Further information can be found in the instruction manual of the electrolyte monitoring, see <a href="#">user manual Type 8201</a> ▶. For ordering information, see chapter <a href="#">“9.6. Ordering chart accessories” on page 14</a>.</p>	

### 8.2. Maintenance sets

Since the enamelled pH sensor does not deteriorate and is largely insensitive to dirt, the maintenance and cleaning of the sensor system is minimal.

- Maintenance sets for the pH sensor and for the electrolyte vessel are available. They contain small parts such as O-rings, seals, stainless steel cannula, flexible tubing, couplings etc.
- You may need to disinfect and rinse the measuring system. For this you will require demineralised water and a plastic bottle with septum for alcohol filling.

See chapter [“9.6. Ordering chart accessories” on page 14](#) for more information.

## Type 8201

### 9. Ordering information

#### 9.1. Bürkert eShop



**Bürkert eShop – Easy ordering and quick delivery**

You want to find your desired Bürkert product or spare part quickly and order directly? Our online shop is available for you 24/7. Sign up and enjoy all the benefits.

[Order online now](#)

#### 9.2. Recommendation regarding product selection

**Note:**

Select the cable between the probe and transmitter as short as possible, especially at low process temperatures, to ensure the highest possible dynamic range of the measurement signal. Only use a cable length of 10 m in **exceptional cases**, contact your Bürkert sales office for application advice.

A complete Type 8201 pH measuring system contains the following components:

- pH probe enamel
- Suitable adaptation set for fitting/armature
- Fitting/armature
- Electrolyte vessel (electrolyte hose included)
- Supply bottle with 1 litre electrolyte KCl
- Connection cable for transmitter
- Transmitter/Controller Type 8619 (see **data sheet Type 8619** ▶ for more information)
- Pressure controller (see **data sheet Type TPM001** ▶ for more information) or another one available on the market

Seven different components must be ordered in order to select a complete device. The following information is required:

- **Article no.** of the pH probe enamel (see chapter “9.5. Ordering chart” on page 13)
- **Article no.** of the suitable adaptation set for fitting/armature (see chapter “9.5. Ordering chart” on page 13)
- **Article no.** of the fitting Type 8201(see chapter “9.5. Ordering chart” on page 13) or armature Type 8200 (see **data sheet Type 8200** ▶ for more information)
- **Article no.** of the electrolyte vessel (see chapter “9.5. Ordering chart” on page 13)
- **Article no.** of the supply bottle with 1 litre electrolyte KCl (see chapter “9.5. Ordering chart” on page 13)
- **Article no.** of the connection cable for transmitter (see chapter “9.5. Ordering chart” on page 13)
- **Article no.** of the Transmitter/Controller Type 8619 (see **data sheet Type 8619** ▶ for more information)
- **Article no.** of a pressure controller Type TPM001 (see **data sheet Type TPM001** ▶ for more information)

#### 9.3. Bürkert product filter

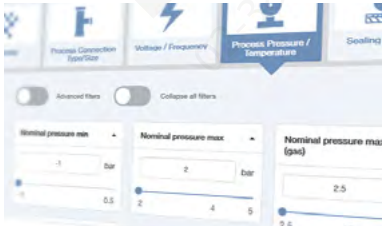

**Bürkert product filter – Get quickly to the right product**

You want to select products comfortably based on your technical requirements? Use the Bürkert product filter and find suitable articles for your application quickly and easily.

[Try out our product filter](#)

## Type 8201

### 9.4. Bürkert Product Enquiry Form

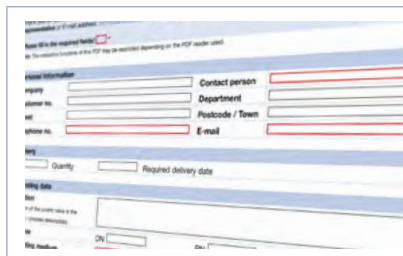

#### Bürkert Product Enquiry Form – Your enquiry quickly and compactly

















Would you like to make a specific product enquiry based on your technical requirements? Use our Product Enquiry Form for this purpose. There you will find all the relevant information for your Bürkert contact. This will enable us to provide you with the best possible advice.

[Fill out the form now](#)

### 9.5. Ordering chart

#### Note:

All parts required for a complete measurement system (see chapter “9.2. Recommendation regarding product selection” on page 12) must be ordered separately.





Description	Remark	Article no.
<b>Probe</b>		
pH probe enamel without adaptation	pH measuring range: 0...10 (12) Medium temperature: 0...+ 140 °C Pressure (relative): - 1...6 bar Electrical connection: 6-pin gold-plated	554849 
<b>Adaptation sets</b>		
Adaptation set for weld spigot DN 25 Type 8201	Union nut G 1¼" / DN 25	554866 
Adaptation set for weld spigot DN 30 Type 8201	Union nut G 1¼" / DN 30	554873 
Adaptation set PG 13.5 for pH armature Type 8200	PG 13.5 with O-ring	554862 
Adaptation set for flange connection adapted for GEA Tuchenhagen VARINLINE process connection (DN 50...DN 125)	Flange adapted for GEA Tuchenhagen VARINLINE process connection	558617 
Adaptation set Clamp 2" external Ø 64 mm	Clamp 2"	559744 
<b>Electrolyte vessel</b>		
Electrolyte vessel, stainless steel	Including electrolyte hose set 5 m, compressed air connection, pipe and wall-mounting set	554850 
Electrolyte vessel, stainless steel, with level switch		554851 
<b>Operating liquids</b>		
Electrolyte KCl, sterilised, 1 litre plastic bottle (conform to FDA)	Electrolyte reference system	554852 
<b>Connection cables</b>		
Connection cable for pH probe enamel, 3 m long	6-pin Variopin coupling on pH probe, flexes on transmitter	554855 
Connection cable for pH probe enamel, 5 m long		554856 
Connection cable for pH probe enamel, 10 m long <sup>1)</sup>		554857 
<b>Fittings Type 8201</b>		
Weld spigot DN 25, 40 mm, straight, 1.4404	DN 25/weld attachment straight	554858 
Weld spigot DN 25, 40 mm, sloped, 1.4404	DN 25/weld attachment diagonal	554859 
Weld spigot, DN 30, 60 mm, straight, 1.4404	DN 30/weld attachment straight	554860 
Blind plug for weld spigot, DN 30, 1.4404 <sup>2)</sup>	Union nut G 1¼" / DN 30	554861 
Nut for blind plug for weld spigot, DN 30, 1.4404 <sup>2)</sup>	G 1¼" / DN 30	554872 

1.) Only to be used in exceptional cases. Contact your Bürkert sales office for application advice.

2.) Mandatory to prevent warpage when welding the DN 30 weld-in spigot.

## Type 8201

### 9.6. Ordering chart accessories

Description	Article no.
<b>Level switch</b>	
Ultrasonic detection electrolyte level switch, with 5-pin M12 male connector (includes a 5 meter long cable with a right-angled 5-pin M12 female connector)	561533 
<b>Maintenance sets</b>	
Maintenance set for pH probe enamel with two O-rings 10 × 2.5 mm made of EPDM, two O-rings 20 × 2.5 mm made of silicone, two O-rings 23.39 × 3.53 mm made of EPDM and four supporting rings made of PTFE for spacer tube	554876 
Electrolyte supply line set with one hose coupling with shut-off, one hose connector with shut-off and one hose 4 × 1 mm, length 5 m, made of PTFE	554883 
<b>Cleaning</b>	
Plastic bottle with septum, to be filled with alcohol 70 %	554854 

To describe your process, use the product enquiry form, see chapter “9.4. Bürkert Product Enquiry Form” on page 13 and send it to your Bürkert sales office to check the suitability.

