



Flow transmitter to use on Inline sensor-fitting for hazardous areas II 1 G/D - II 3 GD

- Flowmeter with NAMUR or NPN/PNP output signal
- Mounting, dismounting of electronics by a Quarter-Turn
- Protection-Ex:
 - Intrinsically safe (ignition protection type i) certified NAMUR variant for use in Zone 0, 1, 2 - Gas (G) or 20, 21, 22 - Dust (D)
 - non-sparking (ignition protection type ec) certified NPN/PNP variant for use in Zone 2 - Gas (G) or 22 - Dust (D)3

Product variants described in the data sheet may differ from the product presentation and description.

Can be combined with

	Type 8619 multiCELL - transmitter/controller	▶
	Type 8611 eCONTROL - Universal controller	▶
	Type 8025 Flow transmitter or remote batch controller	▶
	Intrinsic safety barrier with NAMUR input	▶
	PLC	

Type description

The flow transmitter Type SE30 Ex for continuous flow measurement is especially designed for use in neutral, slightly aggressive, solid-free liquids, in hazardous environments.

The complete flowmeter is made up of an electronic module and a measuring element, either a Inline sensor-fitting Type S030 with PVDF paddle-wheel or a Inline sensor-fitting Type S077, quickly and easily connected together by a Quarter-Turn.

The electronic module detects the paddle-wheel (Type S030) or oval gear (Type S077) rotation, modulates the current of the power supply line according to NAMUR standard or produces an NPN/PNP output signal (depends on model). To operate the NAMUR signal, an intrinsic safety barrier should be connected to the flowmeter Type SE30 Ex.

The connection to another device in the safe area depends on the used flowmeter model.

DTS 1000049988 EN Version: X Status: RL (released | freigegeben | valide) printed: 21.08.2024



Table of contents

1. General technical data	3
1.1. About the device.....	3
1.2. All variants.....	3
1.3. Transmitter with a Namur output signal	4
1.4. Transmitter with an NPN/PNP output signal.....	5
2. Approvals and conformities	5
2.1. Conformity	5
2.2. Standards.....	5
2.3. Explosion protection.....	5
3. Materials	6
3.1. Bürkert resistApp	6
3.2. Material specifications	6
4. Dimensions	7
4.1. Transmitter Type SE30 Ex, variant NAMUR.....	7
4.2. Transmitter Type SE30 Ex, variant PNP/NPN.....	7
4.3. Transmitter Type SE30 Ex mounted on a Type S030 sensor-fitting.....	8
4.4. Transmitter Type SE30 Ex mounted on a Type S077 sensor-fitting	8
5. Performance specifications	9
5.1. Pressure temperature diagram	9
6. Product installation	9
6.1. Installation notes.....	9
Installation into Type S030 sensor fitting.....	9
Installation into Type S077 sensor fitting	10
6.2. Overview of hazardous areas depending on Type SE30 Ex flow transmitter models (according to ATEX).....	11
6.3. Safety instructions - Notice of ATEX instructions.....	11
7. Product operation	13
7.1. Measuring principle	13
8. Product design and assembly	13
8.1. Product assembly	13
9. Product accessories	14
10. Networking and combination with other Bürkert products	15
10.1. Type SE30 Ex with marking II 1 G/D (NAMUR variant).....	15
10.2. Type SE30 Ex with marking II 3 GD (NPN/PNP variant)	15
11. Ordering information	15
11.1. Bürkert eShop	15
11.2. Recommendation regarding product selection.....	16
11.3. Bürkert product filter.....	16
11.4. Ordering chart	16
11.5. Ordering chart accessories.....	16
Cable plug.....	16
Intrinsic safety barrier	16

1. General technical data

1.1. About the device

A complete flowmeter for hazardous areas is available

- either with a Namur output signal (variant NAMUR)
- or with an NPN/PNP output signal (variant NPN/PNP)

and with a wide variety of process connection according to the sensor-fitting Type S030 or Type S077 on which the transmitter Type SE30 Ex is mounted.

Further information can be found in [data sheet Type S030](#) or [data sheet Type S077](#) and further information on the restrictions on the use of sensors can be found in chapter [“6.3. Safety instructions - Notice of ATEX instructions” on page 11.](#)

1.2. All variants

The following data applies to all variants.

Product properties	
Material	
Make sure the device materials are compatible with the fluid you are using. Further information can be found in chapter “3.1. Bürkert resistApp” on page 6.	
Further information on the materials can be found in chapter “3.2. Material specifications” on page 6.	
Non wetted parts	
Screw	Stainless steel
Female cable plug	<ul style="list-style-type: none"> • Body, contact holder and cable gland in PA • Cable gland seal and flat seal in silicone
Wetted parts	
Sensor-fitting body	Depend on the selected sensor-fitting Type. Further information on sensor-fitting can be found in the data sheet of the used Inline sensor-fittings, see data sheet Type S030 or data sheet Type S077 and restrictions on the use of the sensors can be found in chapter “6.3. Safety instructions - Notice of ATEX instructions” on page 11.
Compatibility	<ul style="list-style-type: none"> • Any pipe from DN 06...DN 65 which are fitted with Bürkert Type S030 Inline sensor-fitting. For the selection of the nominal diameter and materials of the Inline sensor-fittings, see data sheet Type S030. • Any pipe from DN 15...DN 50 which is fitted with Bürkert Type S077 Inline sensor-fitting. For the selection of the nominal diameter and materials of the Inline sensor-fittings, see data sheet Type S077. <p>Further information on the restrictions on the use of sensors can be found in chapter “6.3. Safety instructions - Notice of ATEX instructions” on page 11.</p>
Dimensions	Further information can be found in chapter “4. Dimensions” on page 7.
Measuring range	<ul style="list-style-type: none"> • Used with Type S030 sensor-fitting Flow rate: 0.5...1200 l/min (0.13...317 gpm) with flow velocity: 0.3...10 m/s • Used with Type S077 sensor-fitting Flow rate: 2...350 l/min (0.53...92.46 gpm) with viscosity > 5 cps or 3...300 l/min (0.79...79.25 gpm) with viscosity < 5 cps
Performance data	
Measurement deviation	<ul style="list-style-type: none"> • Used with Type S030 sensor-fitting: <ul style="list-style-type: none"> – Teach-In (via a connected remote transmitter, e.g. Type 8025): ± 1% of the measured value¹⁾ (at Teach-In flow rate value) – Standard K-factor: ± 2.5 % of the measured value¹⁾ • Used with Type S077 sensor-fitting: ± 0.5 % of the measured value
Linearity	± 0.5 % of full scale ¹⁾
Repeatability	<ul style="list-style-type: none"> • Used with Type S030 sensor-fitting: ± 0.4 % of the measured value¹⁾ • Used with Type S077 sensor-fitting: ± 0.3 % of the measured value
Electrical data	
Protection against DC polarity reversal	Yes

DTS 1000049988 EN Version: X Status: RL (released | freigegeben | valide) printed: 21.08.2024

Voltage supply cable	<ul style="list-style-type: none"> • Cable with maximum operating temperature greater than 80 °C • Max. 50 m length, shielded • External diameter of wire: 5...8 mm • Cross section of wires: 0.5...1.5 mm² • Cross section the local ground wire: max. 0.75 mm² • Line impedance of the conductors: < 50 Ω
----------------------	--

Medium data

Fluid temperature	Max. + 80 °C (+ 176 °F)
-------------------	-------------------------

Approvals and conformities

Directives

CE directive	Further information on the CE Directive can be found in chapter "2.2. Standards" on page 5.
Explosion protection	ATEX Further information on the ATEX certification can be found in chapter "6.3. Safety instructions - Notice of ATEX instructions" on page 11.

Environment and installation

Ambient temperature	Operation and storage: - 15...+ 60 °C (+ 32...+ 140 °F)
Relative air humidity	≤ 80 %, without condensation
Height above sea level	Max. 2000 m
Operating condition	Continuous
Equipment mobility	Fixed
Application range	Indoor and outdoor Protect the device against electromagnetic interference, ultraviolet rays and, when installed outdoors, against the effects of climatic conditions.
Degree of protection according to IEC/ EN 60529	IP67 with connector plugged-in and tightened
Installation category	Category I according to UL/EN 61010-1
Pollution degree	Degree 2 according to UL/EN 61010-1

1.) Under reference conditions i.e. measuring medium = water, ambient and water temperature = + 20 °C (+ 68 °F), observing the minimum the minimum inlet and outlet sections and the appropriate inner diameter of the pipe.

1.3. Transmitter with a Namur output signal

Product properties

Material

Non wetted parts

Cover (male fixed plug)	PPS, glass fibre reinforced
Housing	PPS, glass fibre reinforced
Bayonet system	PPS, glass fibre reinforced

Electrical data

Operating voltage ¹⁾	8...15 V DC (from connected intrinsic safety barrier)
Current consumption	With sensor: ≤ 7 mA
Output	2-wire current modulation according to NAMUR (0.5 or 2.5 mA)

Connections & communication

Electrical connection	Cable plug Form A acc. to EN 175301-803 (supplied)
-----------------------	--

Approvals and conformities

Others	NAMUR: EN 60947-5-6
--------	---------------------

1.) To select a suitable power supply for the place of use, see chapter **"6.3. Safety instructions - Notice of ATEX instructions"** on page 11.

DTS 1000049988 EN Version: X Status: RL (released | freigegeben | validé) printed: 21.08.2024

1.4. Transmitter with an NPN/PNP output signal

Product properties	
Material	
Non wetted parts	
Cover (male fixed plug)	PC
Housing	PC
Bayonet system	PC
Electrical data	
Operating voltage ¹⁾	12...36 V DC
Current consumption	30 mA
Output	NPN/PNP
Connections & communication	
Electrical connection	Cable plug Form A acc. to EN 175301-803 with 5 or 12 m cable (not supplied)

1.) To select a suitable power supply for the place of use, see chapter "6.3. Safety instructions - Notice of ATEX instructions" on page 11.

2. Approvals and conformities

2.1. Conformity

In accordance with the Declaration of Conformity, the product is compliant with the EU Directives.

2.2. Standards

The applied standards which are used to demonstrate compliance with the EU Directives are listed in the EU-Type Examination Certificate and/or the EU Declaration of Conformity.

2.3. Explosion protection

Approval	Description						
	<p>Optional: Explosion protection Ex marking of the components according to the following table:</p> <table border="1"> <thead> <tr> <th>NAMUR variant</th> <th>NPN/PNP variant</th> </tr> </thead> <tbody> <tr> <td>As category 1 device suitable for zone 0, 1 and 2/20, 21 and 22.</td> <td>As category 3 device suitable for zone 2/22.</td> </tr> <tr> <td> <p>ATEX</p> <ul style="list-style-type: none"> • II 1 GD Ex ia IIC T6 • Ex iaD 20 IP6X T80 °C </td> <td> <p>ATEX</p> <ul style="list-style-type: none"> • II 3 GD • Ex ec IIC T4 Gc • Ex tc IIIC T135 °C Dc IP6Xc </td> </tr> </tbody> </table>	NAMUR variant	NPN/PNP variant	As category 1 device suitable for zone 0, 1 and 2/20, 21 and 22.	As category 3 device suitable for zone 2/22.	<p>ATEX</p> <ul style="list-style-type: none"> • II 1 GD Ex ia IIC T6 • Ex iaD 20 IP6X T80 °C 	<p>ATEX</p> <ul style="list-style-type: none"> • II 3 GD • Ex ec IIC T4 Gc • Ex tc IIIC T135 °C Dc IP6Xc
	NAMUR variant	NPN/PNP variant					
As category 1 device suitable for zone 0, 1 and 2/20, 21 and 22.	As category 3 device suitable for zone 2/22.						
<p>ATEX</p> <ul style="list-style-type: none"> • II 1 GD Ex ia IIC T6 • Ex iaD 20 IP6X T80 °C 	<p>ATEX</p> <ul style="list-style-type: none"> • II 3 GD • Ex ec IIC T4 Gc • Ex tc IIIC T135 °C Dc IP6Xc 						
<p>Measures to comply with ATEX requirements: refer to</p> <ul style="list-style-type: none"> • chapter "6.3. Safety instructions - Notice of ATEX instructions" on page 11 or • Additional information PX011-PX12-PX13 Use in the explosion-hazardous area ▶ under user manual. <p>The Ex certification is only valid if the Bürkert device is used as described in the supplement ATEX. If unauthorized changes are made to the device, the Ex certification becomes invalid.</p>							

DTS 1000049988 EN Version: X Status: RL (released | freigegeben | validé) printed: 21.08.2024

3. Materials

3.1. Bürkert resistApp



Bürkert resistApp – Chemical resistance chart

You want to ensure the reliability and durability of the materials in your individual application case? Verify your combination of media and materials on our website or in our resistApp.

[Start chemical resistance check](#)

3.2. Material specifications

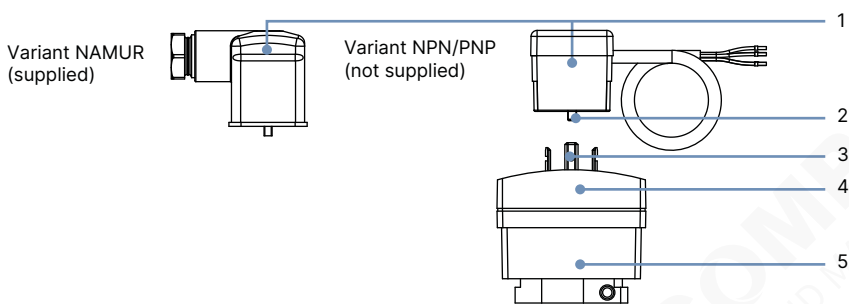

No.	Description	Material
1	Female cable plug	<ul style="list-style-type: none"> Variant Namur: PA with silicone seal Variant PNP/NPN: PA with NBR seal
2	Screws	Stainless steel
3	Electrical contact	Sn
4	Cover (male fixed plug)	PC
5	Housing	<ul style="list-style-type: none"> Variant Namur: PPS, glass fibre reinforced Variant PNP/NPN: PC

DTS 1000049988 EN Version: X Status: RL (released | freigegeben | validé) printed: 21.08.2024

4. Dimensions

4.1. Transmitter Type SE30 Ex, variant NAMUR

Note:

- Dimensions in mm, unless otherwise stated
- The cable plug (DIN EN 175301-803) is supplied in the scope of delivery.

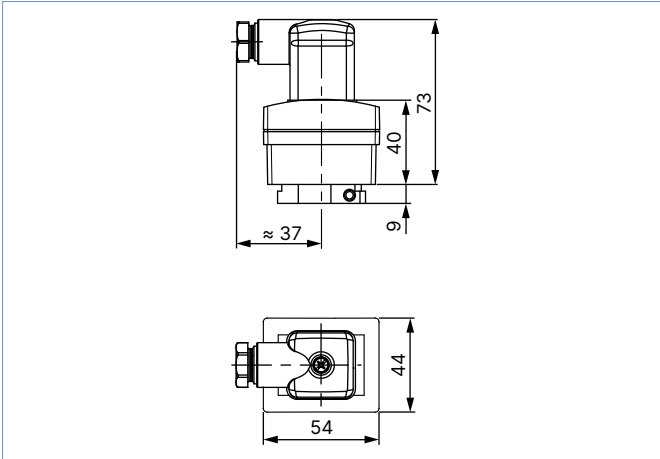

4.2. Transmitter Type SE30 Ex, variant PNP/NPN

Note:

- Dimensions in mm, unless otherwise stated
- The cable plug Type 2513 with 5 m cable or 12 m cable is not supplied in the scope of delivery and must be ordered separately. The cable outlet is **always oriented perpendicularly** to the pipeline, see **data sheet Type 2513** ▶.

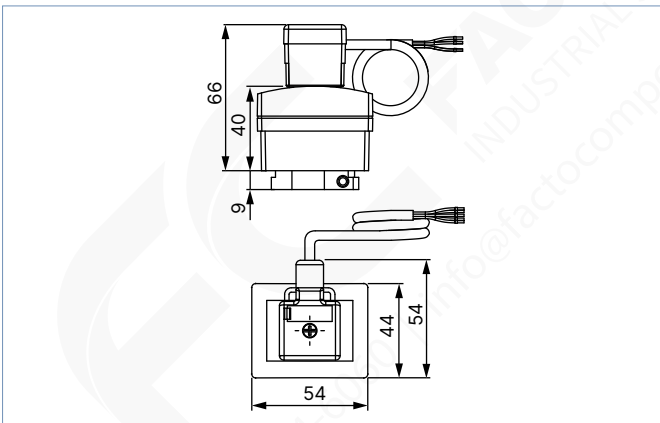

4.3. Transmitter Type SE30 Ex mounted on a Type S030 sensor-fitting

Note:

- Dimensions in mm, unless otherwise stated
- The cable plug (DIN EN 175301-803) is supplied in the scope of delivery.
- The cable plug Type 2513 with 5 m cable or 12 m cable is not supplied in the scope of delivery and must be ordered separately. The cable outlet is **always oriented perpendicularly** to the pipeline, see **data sheet Type 2513** ▶.

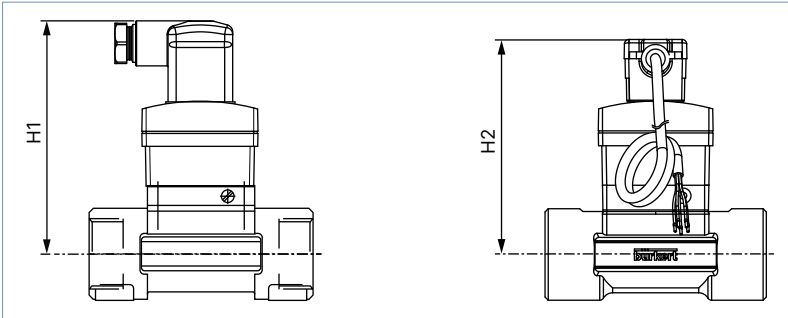

DN	H1	H2
06	102.5	95.5
08	102.5	95.5
15	107.5	100.5
20	105.0	98.0
25	105.0	98.0
32	109.0	102.0
40	112.5	105.5
50	117.0	112.0
65	117.0	112.0

4.4. Transmitter Type SE30 Ex mounted on a Type S077 sensor-fitting

Note:

- Dimensions in mm, unless otherwise stated
- The cable plug (DIN EN 175301-803) is supplied in the scope of delivery.
- The cable plug Type 2513 with 5 m cable or 12 m cable is not supplied in the scope of delivery and must be ordered separately. The cable outlet is **always oriented perpendicularly** to the pipeline, see **data sheet Type 2513** ▶.

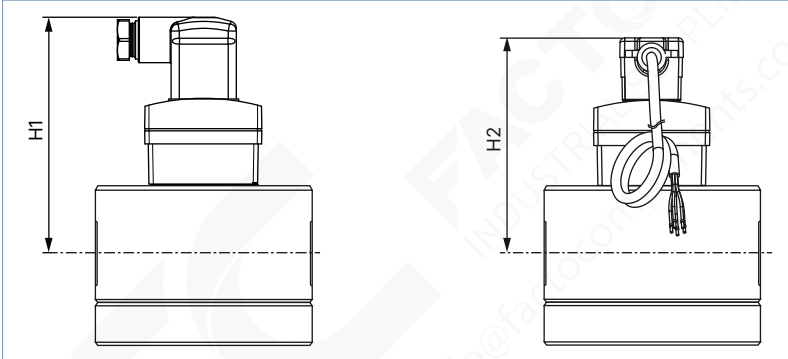

DN	H1	H2
15	94	87
25	103	96
40	115	108
50	125	118
80	175	168

DN 15	DN 25	DN 40	DN 50	DN 80
Threaded connection				
DN 25	DN 40	DN 50	DN 80	
Flanged connection				

DTS 1000049988 EN Version: X Status: RL (released | freigegeben | validé) printed: 21.08.2024

5. Performance specifications

5.1. Pressure temperature diagram

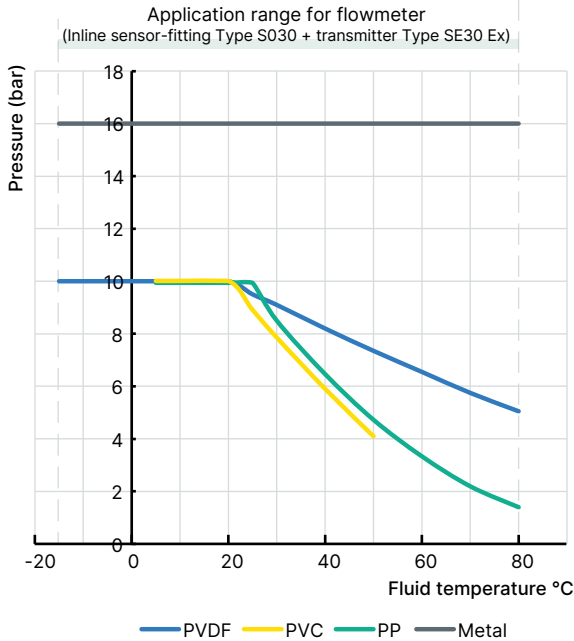

6. Product installation

6.1. Installation notes

Installation into Type S030 sensor fitting

Note:

The device is not suitable for use in gaseous media and steam.

Minimum straight distances upstream and downstream of the sensor must be observed. These stabilizing distances depend on the pipe's design. Increasing these distances or installing a flow conditioner may be necessary to obtain the best accuracy. For more information, refer to EN ISO 5167-1.

EN ISO 5167-1 specifies the straight inlet and outlet distances that must be complied with when installing fittings in pipe lines in order to achieve calm flow conditions. The most commonly used elements that could lead to turbulence in the flow are shown below. The related minimum inlet and outlet distances that ensure a calm flow are also specified.

Make sure that the measuring conditions at the point of measurement are calm and problem-free.

DN = Orifice

Fluid direction →

Regulating valve¹⁾

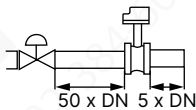

2 x 90° elbow joint

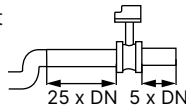

Expansion²⁾

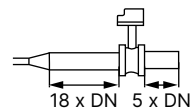

2 x 90° elbow joint
3 dimensional

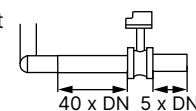

90° elbow joint
or T-piece

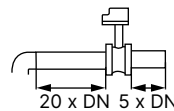

Reduction

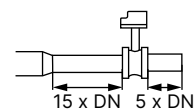

1.) If the valve cannot be mounted after the measuring device, the minimal distances have to be respected.

2.) If an expansion cannot be avoided, the minimal distances have to be respected.
Please note minimum flow velocity

The device can be installed in either horizontal or vertical pipes, but following additional conditions should be respected:

- The pipe always has to be filled with fluid at all times near the device.

- The pipe design must be such that no air bubbles or cavitation can form within the medium near the device at any time.

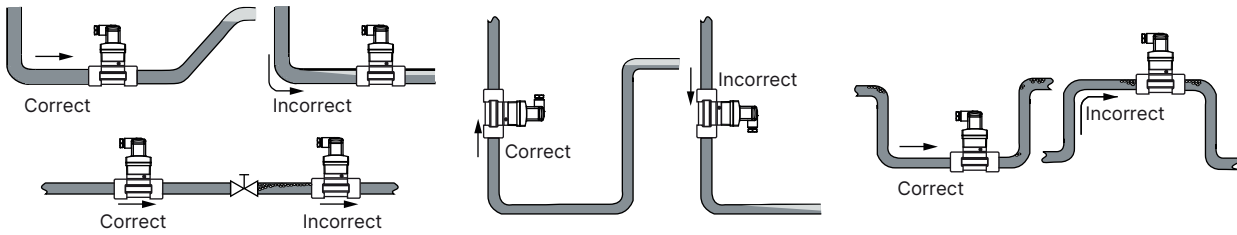

Pressure and temperature ratings must be respected according to the selected fitting material. The suitable pipe size is selected using the diagram in the chapter "Nominal size selection" of the **data sheet Type S030** and further information for using restriction can be found in chapter "6.3. Safety instructions - Notice of ATEX instructions" on page 11.

Installation into Type S077 sensor fitting

Note:

The device is not suitable for use in gaseous media and steam.

The sensor fitting can be installed in any orientation as long as **the rotor shafts are always in a horizontal plane.**

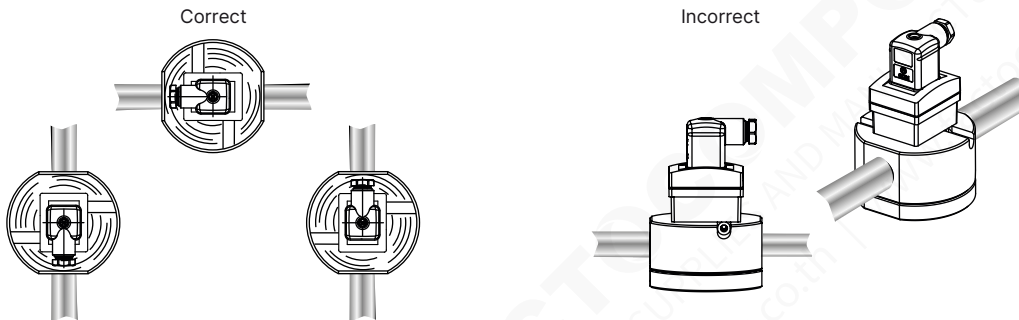

The following installation conditions must also be observed:

- The pipe always has to be filled with fluid at all times near the device.
- The pipe design must be such that no air bubbles or cavitation can form within the medium near the device at any time.
- We recommend the installation of a 250 µm strainer as close as possible to the inlet side of the meter, to prevent damage from particles,
- Air purges can damage the appliance and should therefore be avoided.

DTS 1000049988 EN Version: X Status: RL (released | freigegeben | validé) printed: 21.08.2024

6.2. Overview of hazardous areas depending on Type SE30 Ex flow transmitter models (according to ATEX)

This equipment can be installed in some potentially explosive atmospheres (surface industries) and comply with the 2014/34/EU ATEX directives.

Equipment for explosive atmospheres (surface industries) - GROUP II						
Level of protection	Very high		High		Normal	
Zone	Gas, Zone 0	Dust, Zone 20	Gas, Zone 1	Dust, Zone 21	Gas, Zone 2	Dust, Zone 22
Explosive atmospheres	Present continuously, long periods or frequently	Present continuously, long periods or frequently	Are likely to occur	Are likely to occur	Are unlikely to occur or present only infrequently and for a short period only	Are unlikely to occur or present only infrequently and for a short period only
CATEGORY 1 SE30 Ex - NAMUR II 1 G/D (Article no. 552901) EEx ia IIC T6 - IP6X T80 °C associated with sensor fittings made of PVDF, brass, stainless steel or aluminium	To use with intrinsic safety barrier with NAMUR input (The open circuit voltage for the NAMUR input must be included between 8 and 15 V). 					
CATEGORY 3 SE30 Ex - II 3 GD - NPN/PNP (Article no. 552353) Ex ec IIC T4 Gc Ex tc IIIC T135 °C Dc IP6X associated with sensor fittings made of PVDF, brass, stainless steel or aluminium	Not to be used		Not to be used		to use with a 12...36 V supply source	

6.3. Safety instructions - Notice of ATEX instructions

Note:

The appropriate Type SE30 Ex flowmeter variant depends on the installation environment.

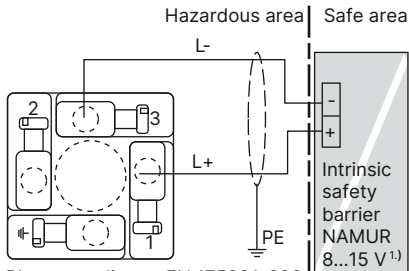
Flowmeter Type SE30 Ex NAMUR (Article no. 552901) Group II - Category 1 for potentially explosive zones of gas (0, 1 and 2) and dust (20, 21 and 22)													
<ul style="list-style-type: none"> ATEX marking identification and ATEX installation zones <p>CE 0102 II 1 GD Ex ia IIC T6 Ex iaD 20 IP6X T80 °C ambient T: 0 °C ≤ Ta ≤ 60 °C</p> <p>LCIE 04 ATEX 6070 X</p> <ul style="list-style-type: none"> Special conditions for a safe use <p>The device is intrinsic safety certified and may be installed in potentially explosive atmospheres: zones 0, 1 or 2 and zones 20, 21 or 22.</p> <p>The connector can only be connected to certified intrinsic safety equipment. This combination must be compatible with intrinsic safety rules (see electrical safety data in the table under the adjacent connection diagram).</p> <p>The ambient temperature of use must always be between these limits: from 0...+ 60 °C.</p> <ul style="list-style-type: none"> Compatible mechanical assembly and fluid connections: <p> Use only sensor fitting made of PVDF, brass, stainless steel or aluminium. Any other connection is prohibited.</p>	<div style="display: flex; justify-content: space-between;"> <div style="width: 45%;">  <p>Plug according to EN 175301-803 of the SE30 Ex</p> <p>1.) Use an appropriate power supply which complies with the following electrical specifications</p> <p>Earth the shielding of the cable on side of the measuring exploitation</p> </div> <div style="width: 45%; border: 1px solid black; padding: 5px;"> <table border="1"> <thead> <tr> <th colspan="2">Electrical safety data</th> </tr> </thead> <tbody> <tr> <td>Ui</td> <td>≤ 15 V</td> </tr> <tr> <td>Ii</td> <td>≤ 50 mA</td> </tr> <tr> <td>Pi</td> <td>≤ 188 mW</td> </tr> <tr> <td>Ci</td> <td>≤ 1.2 nF</td> </tr> <tr> <td>Li</td> <td>≈ 0</td> </tr> </tbody> </table> </div> </div>	Electrical safety data		Ui	≤ 15 V	Ii	≤ 50 mA	Pi	≤ 188 mW	Ci	≤ 1.2 nF	Li	≈ 0
Electrical safety data													
Ui	≤ 15 V												
Ii	≤ 50 mA												
Pi	≤ 188 mW												
Ci	≤ 1.2 nF												
Li	≈ 0												

DTS 1000049988 EN Version: X Status: RL (released | freigegeben | valide) printed: 21.08.2024

Flowmeter Type SE30 Ex NPN/PNP (Article no. 552353) Group II - Category 3 for potentially explosive zones of gas (2) and dust (22)

• **ATEX marking identification and ATEX installation zones**

CE 0102 II 3 GD
 Ex ec IIC T4 Gc
 Ex tc IIIC T135 °C Dc IP6X
 ambient T: 0 °C ≤ Ta ≤ 50 °C

• **Special conditions for a safe use**

The device is ATEX certified and may be installed in potentially explosive atmospheres: zones 2 or 22.

The connector may be connected to a 12...36 V supply source.

The ambient temperature of use must always be between these limits: from 0...+ 50 °C.

• Compatible mechanical assembly and fluid connections:

Sensor fittings made of PVDF, brass, stainless steel, aluminium can be used. Any other connection is prohibited.

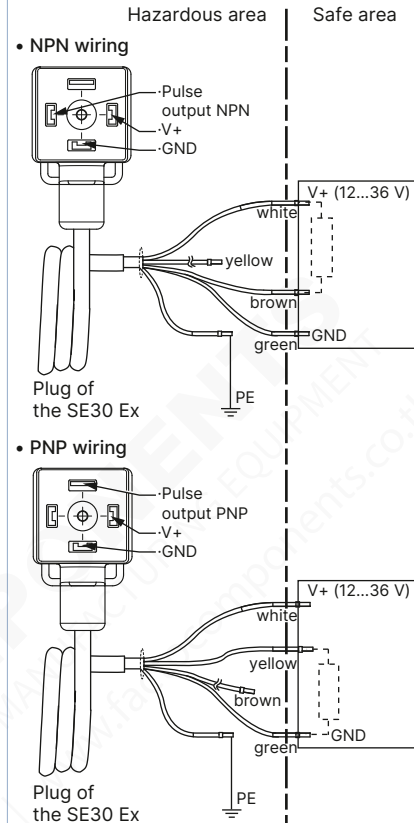

Electrical safety data on power supply line (L+/L-)	
U_{max.}	36 V
I_{max.}	30 mA
P_{max.}	108 mW

DTS 1000049988 EN Version: X Status: RL (released | freigegeben | validé) printed: 21.08.2024

FACTOCOMPONENTS

INDUSTRIAL SUPPLIES AND MATERIALS

02-384-6060 | info@factocomponents.co.th

7. Product operation

7.1. Measuring principle

When liquid flows through the pipe, the paddle wheel with 4 inserted magnets or of the oval gear of the sensor-fitting Type S030 or Type S077 respectively is set in rotation, producing a measuring signal in the transmitter Type SE30 Ex.

- For the NAMUR variant, the electronic module modulates the current of the 2-wire supply line according to NAMUR standard. The modulated frequency of this signal is proportional to the flow rate. This signal is converted, by the connected type NAMUR intrinsic safety barrier, into a frequency signal on its open collector output.
The electrical connection of the flowmeter is made via a cable plug (Type 2518 supplied, see **data sheet Type 2518** ▶).
- For the NPN/PNP variant, the generating signal, which frequency is proportional to the flow rate, can be displayed or processed directly. The electrical connection of the flowmeter is made via a cable plug with 5 or 12 m cable (Type 2513 not supplied, has to be ordered separately, see **data sheet Type 2513** ▶).

A K-factor (available in the **instruction manual of the Type S030 fitting** ▶ or **instruction manual of the Type S077 fitting** ▶) specific to each pipe (size and material) enables the conversion of this frequency into a flow rate/volume.

8. Product design and assembly

8.1. Product assembly

Note:

- A complete device to measure the flow rate is made up of a Inline sensor fitting Type S030 or Type S077 respectively with integrated paddle wheel or oval gear and a transmitter Type SE30 Ex.
- The Inline sensor-fitting Type S030 ensures simple installation into pipes from DN 06...DN 65. The transmitter Type SE30 Ex can easily be mounted on any Inline sensor fitting Type S030 and fastened with a bayonet catch.
- The Inline sensor-fitting Type S077 ensures simple installation into pipes from DN 15...DN 80. . The transmitter Type SE30 Ex can easily be mounted on any Inline sensor fitting Type S077 and fastened with a bayonet catch.

See **data sheet Type S030** ▶ or **data sheet Type S077** ▶ for more information.

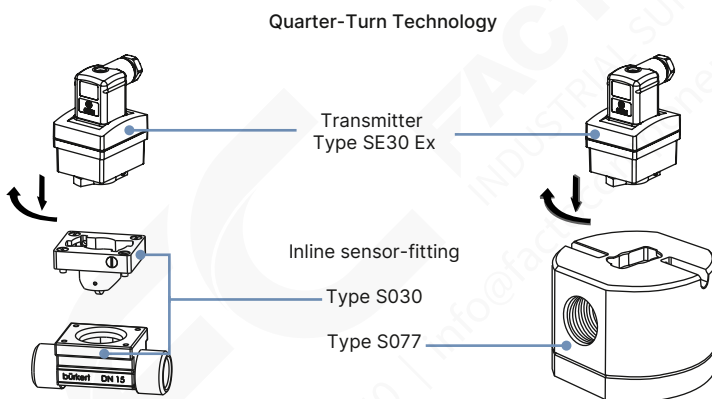

9. Product accessories

Note:

To operate this NAMUR signal, an intrinsically safe barrier must be connected to the flowmeter Type SE30 Ex.

Description



- 2 or 4 channels, intrinsic safety digital inputs: proximity detectors NAMUR, contacts...
- Rail mount on hat profile 35 mm
- All connections by removable screw terminals

Product properties

Dimensions	<ul style="list-style-type: none"> • Housing for symmetrical DIN rail (hat profile 35 mm as per standard NFC63015 / EN50022) • Depth: 120 mm • Height: 90...145 mm overall including space for cables • Width on rail: 29.5 mm • Minimal distance between rails: 180 mm
Selection of the sensor type	Inductive or capacitive intrinsic safety certified NAMUR proximity detector or free-potential contacts
Selection of the logic	By a mini-DIP choice of active proximity switches or when contact is NO (Normally Open) or NC (Normally Closed)
Fault detector	<ul style="list-style-type: none"> • For all inputs configured as NAMUR, all models are provided with fault detector (broken line or short-circuit) • In faulty case, the green front LED switches off, the contact of the defective channel opens and the red LED corresponding to the defective channel switches on • Other channels are not affected

Electrical data

Operating voltage	<ul style="list-style-type: none"> • 24 V DC ± 10 % • 230 V AC ± 10 % • 1 front panel yellow LED is "ON" when supply is active
Power consumption	5 VA
Digital input	Each of the 4 x intrinsic safety inputs can be configured independently for a contact or a proximity detector NAMUR as per DIN 19234
Intrinsic safety input	Proximity detector NAMUR as per DIN 19234 or free potential contacts, relays, pressure or temperature switches or push buttons in hazardous area
Non intrinsic safety recopy output	<ul style="list-style-type: none"> • According to the type of sensor and the chosen logic: a green LED on the front panel displays a free-potential contact for each channel without common wire. • Collector cut-off power: 15 V, 60 mA, 0.9 VA, 350 Hz

Connections & communication

Electrical connection	All connections by removable screw terminals and supply distribution by means of a flat cable from one unit to the next one
-----------------------	---

Approvals and conformities

Classification for explosive areas	<ul style="list-style-type: none"> • Intrinsic safety associated apparatus must be installed in safe area and connected to materials installed in zone 0, 1 or 2 - Gas (G) or in zone 20, 21 or 22 - Dust (D) • Classification according to 2014/34/EU ATEX directives: <ul style="list-style-type: none"> - Ex I/II (M1)/(1) G/D [Ex ia] IIC - Safety parameters see EC-type certificate LCIE 00ATEX 6034X
------------------------------------	--

Environment and installation

Ambient temperature	<ul style="list-style-type: none"> • Operating: - 20...+ 60 °C, - 20...+ 50 °C (recommended) • Storage: - 40...+ 80 °C
Installation condition	<ul style="list-style-type: none"> • Mounting on DIN rail: <p>Must take into account thermal dissipation and risk of overheating generated by housings installed side by side. In case of a high concentration inherent safety barrier, we recommend to leave a free space of 10 mm between each group of 8 units (horizontal rail) and between each group of 4 units (vertical rail).</p> • Mounting inside a cabinet: <p>It is recommended to close the electrical cabinet and to ensure a circulation of fresh air even by means of an air conditioner to keep the inside temperature at the level compatible with the recommended operating temperature among the units.</p>

DTS 1000049988 EN Version: X Status: RL (released | freigegeben | valide) printed: 21.08.2024

10. Networking and combination with other Bürkert products

10.1. Type SE30 Ex with marking II 1 G/D (NAMUR variant)

Example:

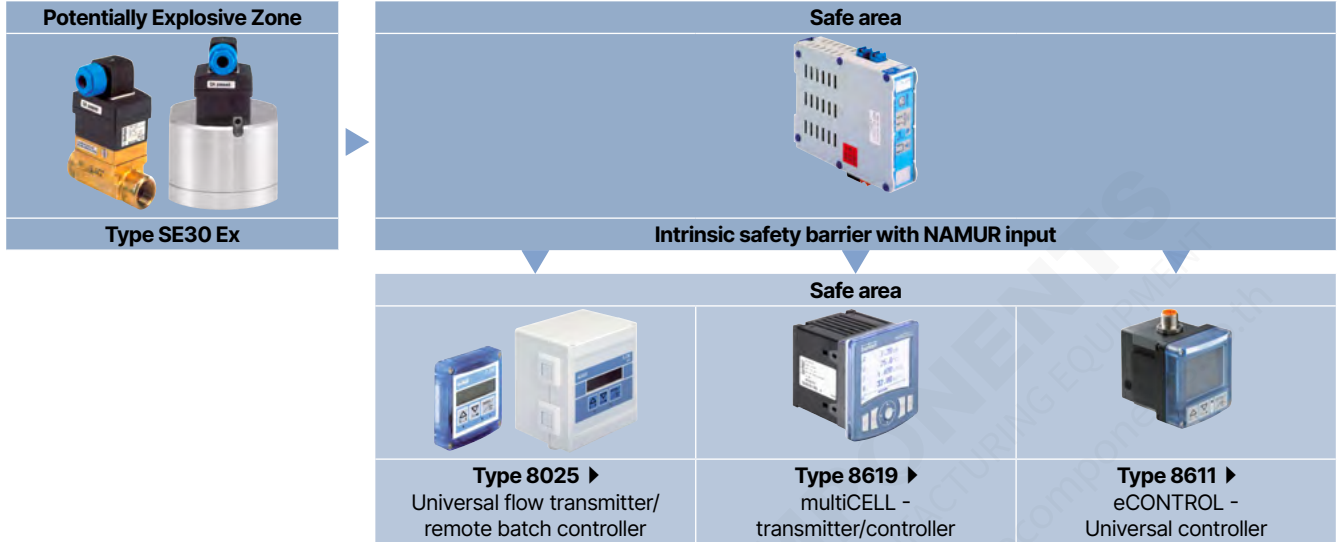

10.2. Type SE30 Ex with marking II 3 GD (NPN/PNP variant)

Example:

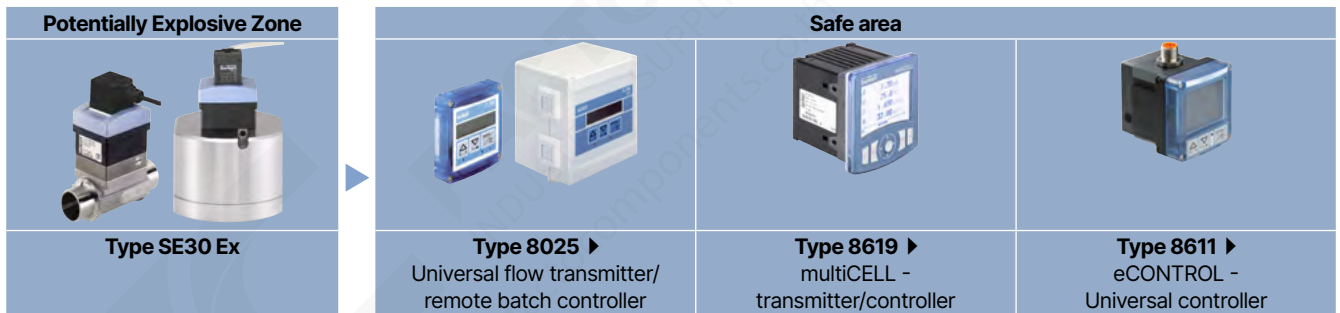

11. Ordering information

11.1. Bürkert eShop



Bürkert eShop – Easy ordering and quick delivery

You want to find your desired Bürkert product or spare part quickly and order directly? Our online shop is available for you 24/7. Sign up and enjoy all the benefits.

[Order online now](#)

11.2. Recommendation regarding product selection

A complete flowmeter for hazardous areas II 1 G/D - II 3 GD consists of a compact SE30 Ex flow transmitter and a Bürkert S030 or S077 Inline sensor-fitting.

Two different components must be ordered in order to select a complete device. The following information is required:

- **Article no.** of the desired compact SE30 Ex flow transmitter (see chapter "11.4. Ordering chart" on page 16).
- **Article no.** of the selected S030 or S077 Inline sensor-fitting (see **data sheet Type S030** ▶ or **data sheet Type S077** ▶)

11.3. Bürkert product filter

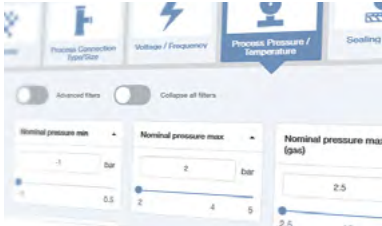

Bürkert product filter – Get quickly to the right product

You want to select products comfortably based on your technical requirements? Use the Bürkert product filter and find suitable articles for your application quickly and easily.

Try out our product filter

11.4. Ordering chart

Description	Operating voltage	Output	Electrical connection	Article no.
SE30 Ex - NAMUR II 1 G/D for explosive gas and dust environments: zones 0, 1 or 2 and 20, 21 or 22	8...15 V DC, via an intrinsic safety barrier with NAMUR input ¹⁾	NAMUR current modulation, 2-wire	Cable plug EN 175301-803	552901
SE30 Ex - II 3 GD for explosive gas and dust environments: zones 2 or 22	12...36 V DC	NPN/PNP		552353

1.) The open circuit voltage for the NAMUR input must be included between 8 and 15 V.

11.5. Ordering chart accessories

Cable plug

Description	Article no.
Female cable plug, 4-pin (3 conductors + protective conductor), form A according to DIN EN 175301-803 with cable gland and flat seal in silicone (Type 2518 ▶) ¹⁾	572330
Female cable plug 28 mm, 4-pin (4 conductors + shielding), form A in accordance with DIN EN 175301-803, cable length: 5 m, NBR seal for NPN/PNP variant (Type 2513 ▶) ²⁾	565558
Female cable plug 28 mm, 4-pin (4 conductors + shielding), form A in accordance with DIN EN 175301-803, cable length: 12 m, NBR seal for NPN/PNP variant (Type 2513 ▶) ²⁾	565559

1.) For NAMUR variant

2.) The cable output is always oriented perpendicularly to the pipe.

Intrinsic safety barrier

Classification of potentially explosive areas	Operating voltage	Outputs	Number of channels	Article no.
2014/34/EU ATEX directives ⊕ I/II (M1)/(1) G/D [EEex ia] IIC	24 V DC	Open collector, 15 V, 60 mA	2, with NAMUR input	553456
			4, with NAMUR input	553457
	230 V AC	Open collector, 15 V, 60 mA	2, with NAMUR input	553458
			4, with NAMUR input	553459

DTS 1000049988 EN Version: X Status: RL (released | freigegeben | valide) printed: 21.08.2024