



### Insertion fitting for flow or analytical measurement

- Universal fitting for Insertion measuring device in pure, aggressive or contaminated liquids
- Large range of process connections: DN 06...DN 400 in PVC, PP, PVDF, PE, stainless steel, brass
- Transmitter available for indication, monitoring, transmitting, On/Off control or batch control

Product variants described in the data sheet may differ from the product presentation and description.

#### Can be combined with

	<b>Type 8020</b> ▶ Insertion flowmeter with paddle wheel for continuous flow measurement
	<b>Type 8025</b> ▶ Insertion flowmeter/batch controller with paddle wheel and flow transmitter/remote batch controller
	<b>Type 8026</b> ▶ Insertion flowmeter with paddle wheel, ELEMENT design
	<b>Type 8041</b> ▶ Magnetic inductive Insertion flowmeter
	<b>Type 8045</b> ▶ Magnetic inductive Insertion flowmeter
	<b>Type 8228</b> ▶ Inductive conductivity meter, ELEMENT Design
	<b>Type 8200</b> ▶ Armatures for analytical sensors

#### Type description

The fitting Type S020 can be used to connect any Insertion device for measurements in a pipe, e. g. for flow, pH, oxidation reduction potential (ORP) and conductivity measurements.

The fitting is available for paddle wheel and electromagnetic flowmeters and analytical measurement devices having a G 2" or a clamp connection.



## Table of contents

<b>1. General technical data</b>	<b>4</b>
<b>2. Approvals and conformities</b>	<b>5</b>
2.1. General notes.....	5
2.2. Conformity .....	5
2.3. Standards.....	5
2.4. Pressure Equipment Directive (PED).....	5
Device used on a pipe .....	5
2.5. Foods and beverages/Hygiene .....	6
<b>3. Materials</b>	<b>6</b>
3.1. Bürkert resistApp .....	6
<b>4. Dimensions</b>	<b>6</b>
4.1. Metal T-fitting for measuring device with G 2" process connection.....	6
Internal thread connection .....	6
External thread connection .....	7
Weld spigot connection .....	8
Clamp connection.....	9
Flange connection.....	9
4.2. Plastic T-fitting for measuring device with G 2" process connection .....	10
True union connection with nut and solvent/fusion socket.....	10
External thread connection .....	10
Solvent/fusion spigot connection .....	11
4.3. Straight connection for measuring device with G 2" process connection.....	11
Weld spigot connection with radius.....	11
Fusion spigot connection.....	12
Screw-on spigot connection.....	13
4.4. Saddle for flowmeter with G 2" process connection .....	13
4.5. Measuring chamber for analytical measuring device with G 2" process connection .....	14
4.6. T-fitting for flowmeter with clamp process connection.....	14
Weld spigot connection .....	14
4.7. Straight connection for flowmeter with clamp process connection .....	15
Weld spigot connection .....	15
<b>5. Performance specifications</b>	<b>15</b>
5.1. Pressure temperature diagram.....	15
<b>6. Product installation</b>	<b>16</b>
6.1. Installation notes .....	16
Flow measurement.....	16
Analytical measurement.....	16
6.2. Selection of the nominal diameter .....	17
<b>7. Product accessories</b>	<b>18</b>
<b>8. Networking and combination with other Bürkert products</b>	<b>19</b>
8.1. Fitting for measuring device with G 2" process connection.....	19
8.2. Fitting for for flowmeter with clamp process connection .....	20
8.3. Combination of the S020 with a measuring device for flow rate, pH or ORP, conductivity measurement.....	21
<b>9. Ordering information</b>	<b>21</b>

- 9.1. Bürkert eShop .....21
- 9.2. Bürkert product filter .....21
- 9.3. Ordering chart .....22
  - Metal T-fitting DN 06...DN 65 for measuring device with G 2" process connection .....22
  - Plastic T-fitting DN 06...DN 65 for measuring device with G 2" process connection .....23
  - Straight connection DN 50...DN 400 for measuring device with G 2" process connection.....24
  - Weld/fusion spigot connection .....24
  - Saddle for flowmeter with G 2" process connection .....24
  - Measuring chamber for analytical measuring device with G 2" process connection.....24
  - T-fitting DN 32...DN 100 for flowmeter Type 8041/8045 with clamp process connection .....24
  - Straight connection DN 32...DN 100 for flowmeter Type 8041/8045 with clamp process connection.....25
- 9.4. Ordering chart accessories .....25
  - Accessories for all variants .....25
  - Accessories for fitting for measuring device with G 2" process connection .....25
  - Accessories for fitting for flowmeter Type 8041/8045 with clamp process connection .....26

DTS 1000011768 EN Version: AR Status: RL (released | freigegeben | validé) printed: 27.05.2024

## 1. General technical data

Product properties	
<b>Material</b>	
Make sure the device materials are compatible with the fluid you are using. Further information can be found in chapter <a href="#">“3.1. Bürkert resistApp”</a> on page 6.	
<b>Non wetted parts</b>	
Screw	Stainless steel (316L - 1.4404)
<b>Wetted parts</b>	
Fitting body	<ul style="list-style-type: none"> <li>For G 2" flowmeter connection: Body &amp; adapter respectively in brass (CuZn<sub>39</sub>Pb<sub>2</sub>) &amp; stainless steel (316L - 1.4404) or all in stainless steel (316L - 1.4404), PVC, PP, PVDF or PE (depending on the fitting variant Type S020)</li> <li>For clamp flowmeter connection: Stainless steel 316L</li> </ul>
Seal	<ul style="list-style-type: none"> <li>For G 2" flowmeter connection: FKM or EPDM (depending on the fitting variant Type S020)</li> <li>For clamp flowmeter connection: none</li> </ul>
Surface quality	For fitting in stainless steel: <ul style="list-style-type: none"> <li>For G 2" flowmeter connection               <ul style="list-style-type: none"> <li>T-fitting                   <ul style="list-style-type: none"> <li>inner surface: Ra &lt; 1.6 µm</li> <li>outer surface: Ra &lt; 3.2 µm</li> </ul> </li> <li>Straight connection and measuring chamber                   <ul style="list-style-type: none"> <li>inner surface: Ra &lt; 1.6 µm</li> <li>outer surface: Ra &lt; 6.3 µm</li> </ul> </li> </ul> </li> <li>For clamp flowmeter connection               <ul style="list-style-type: none"> <li>T-fitting                   <ul style="list-style-type: none"> <li>inner surface: Ra &lt; 0.8 µm (excluding welding seams)</li> <li>outer surface: Ra &lt; 1.6 µm</li> </ul> </li> <li>Straight connection                   <ul style="list-style-type: none"> <li>inner surface: Ra &lt; 0.6 µm</li> <li>outer surface: Ra &lt; 1.2 µm</li> </ul> </li> </ul> </li> </ul>
Compatibility	With flowmeters Type 8020, 8025, 8026, 8041, 8045 or analytical measuring devices Type 8200/8203, 8220 or 8228
Pipe diameter	<ul style="list-style-type: none"> <li>For G 2" flowmeter connection: DN 06...DN 400 Combination between fitting and measuring device is sometimes restricted to some DN. Further information can be found in chapter <a href="#">“8.3. Combination of the S020 with a measuring device for flow rate, pH or ORP, conductivity measurement”</a> on page 21.)</li> <li>For clamp flowmeter connection: DN 32...DN 100</li> </ul>
Dimensions	Further information can be found in chapter <a href="#">“4. Dimensions”</a> on page 6.
<b>Medium data</b>	
Fluid temperature <sup>1)</sup>	For fitting in: <ul style="list-style-type: none"> <li>PVC: 0...+50 °C (+32...+122 °F)</li> <li>PP: 0...+80 °C (+32...+176 °F)</li> <li>PVDF: -15...+100 °C (+5...+212 °F)</li> <li>PE: +5...+70 °C (+41...+158 °F)</li> <li>stainless steel, brass: -15...+160 °C (+5...+320 °F)</li> </ul>
Fluid pressure <sup>1)</sup>	For fitting in: <ul style="list-style-type: none"> <li>plastic: max. PN 10</li> <li>metal: max. PN 16</li> </ul> Further information can be found in chapter <a href="#">“5.1. Pressure temperature diagram”</a> on page 15.
<b>Process/Pipe connection &amp; communication</b>	
Measuring devices connection	G 2" or clamp connection
Pipe connection	For fitting in: <ul style="list-style-type: none"> <li>plastic: true union with nut and solvent/fusion socket, spigot or external thread, saddle</li> <li>metal: internal or external thread, weld ends, clamp or flange</li> </ul>

## Approvals and conformities

### Directives

CE directive	Further information on the CE directive can be found in chapter <b>“2.3. Standards” on page 5.</b>
Pressure equipment directive	Complying with article 4, paragraph 1 of 2014/68/EU directive Further information on the pressure equipment directive can be found in chapter <b>“2.4. Pressure Equipment Directive (PED)” on page 5.</b>

Foods and beverages/Hygiene	FDA declaration of conformity (stainless steel fitting only with EPDM seal) Must be ordered separately. Further information can be found in chapter <b>“Accessories for all variants” on page 25.</b>
-----------------------------	--

Materials	<ul style="list-style-type: none"> <li>• Inspection certificate 3.1 (according to EN-ISO 10204)</li> <li>• Certification of Conformity for the surface Quality (according to DIN4762, DIN4768, ISO/4287/1)</li> </ul> Must be ordered separately. Further information can be found in chapter <b>“Accessories for all variants” on page 25.</b>
-----------	---

Others	<ul style="list-style-type: none"> <li>• 3 points flow calibration certificate</li> <li>• Test report 2.2 (according to EN-ISO 10204)</li> </ul> Must be ordered separately. Further information can be found in chapter <b>“Accessories for all variants” on page 25.</b>
--------	--

## Environment and installation

Ambient temperature	Operation and storage: the temperature limits also depend on the temperature limits of the inserted device, see the relevant data sheet or operating instructions for more information
---------------------	--

1.) The temperature and pressure limits also depend on the temperature or pressure limits of the inserted device, see the relevant data sheet or operating instructions for more information. If the specified temperature or pressure ranges for the fitting and the inserted device are different, use the most restrictive range.

## 2. Approvals and conformities

### 2.1. General notes

- The approvals and conformities listed below must be stated when making enquiries. This is the only way to ensure that the product complies with all required specifications.
- Not all available variants of the device can be supplied with the below mentioned approvals or conformities.

### 2.2. Conformity

In accordance with the Declaration of Conformity, the product is compliant with the EU Directives.

### 2.3. Standards

The applied standards which are used to demonstrate compliance with the EU Directives are listed in the EU-Type Examination Certificate and/or the EU Declaration of Conformity.

### 2.4. Pressure Equipment Directive (PED)

The device conforms to article 4, paragraph 1 of the Pressure Equipment Directive (PED) 2014/68/EU under the following conditions:

#### Device used on a pipe

##### Note:

- The data in the table is independent of the chemical compatibility of the material and the fluid.
- PS = maximum admissible pressure (in bar), DN = nominal diameter of the pipe

Type of fluid	Conditions
Fluid group 1, article 4, paragraph 1.c.i	DN ≤ 25
Fluid group 2, article 4, paragraph 1.c.i	DN ≤ 32 or PS*DN ≤ 1000
Fluid group 1, article 4, paragraph 1.c.ii	DN ≤ 25 or PS*DN ≤ 2000
Fluid group 2, article 4, paragraph 1.c.ii	DN ≤ 200 or PS ≤ 10 or PS*DN ≤ 5000

### 2.5. Foods and beverages/Hygiene

Conformity	Description
FDA	<b>FDA – Code of Federal Regulations (valid for the variable code PL02, PL03)</b> The variants with the housing made of stainless steel materials and the seal made of EPDM materials are compliant in their composition with the Code of Federal Regulations published by the FDA (Food and Drug Administration, USA) according to the manufacturer’s declaration.

## 3. Materials

### 3.1. Bürkert resistApp



#### Bürkert resistApp – Chemical resistance chart

You want to ensure the reliability and durability of the materials in your individual application case? Verify your combination of media and materials on our website or in our resistApp.

[Start chemical resistance check](#)

## 4. Dimensions

### 4.1. Metal T-fitting for measuring device with G 2" process connection

#### Internal thread connection

**Note:**

- Dimensions in mm, unless otherwise stated
- For use with a flowmeter with short sensor
- Suitable from DN 32 for use with an analytical measuring device

According to G, NPT or Rc in stainless steel (316L - 1.4404) and/or brass (CuZn<sub>39</sub>Pb<sub>2</sub>)

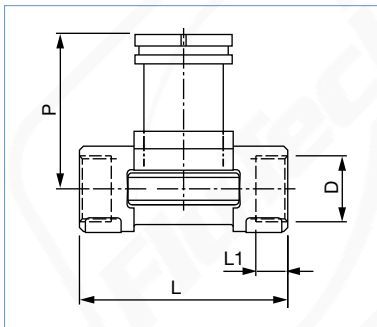

DN	P	L	L1	D
				[inch]
15	80.3	84.0	16.0	G ½
				NPT ½
				Rc ½
20	77.8	94.0	17.0	G ¾
				NPT ¾
				Rc ¾
25	78.0	104.0	23.5	G 1
				NPT 1
				Rc 1
32	81.6	119.0	23.5	G 1 ¼
				NPT 1 ¼
				Rc 1 ¼
40	85.4	129.0	23.5	G 1 ½
				NPT 1 ½
				Rc 1 ½
50	91.5	148.5	27.5	G 2
				NPT 2
				Rc 2

DTS 1000011768 EN Version: AR Status: RL (released | freigegeben | valide) printed: 27.05.2024

**External thread connection**

**Note:**

- Dimensions in mm, unless otherwise stated
- For use with a flowmeter with short sensor
- Suitable from DN 32 for use with an analytical measuring device

According to G in stainless steel (316L - 1.4404) and/or brass (CuZn<sub>39</sub>Pb<sub>2</sub>) or PVC (only DN 06 and DN 08)

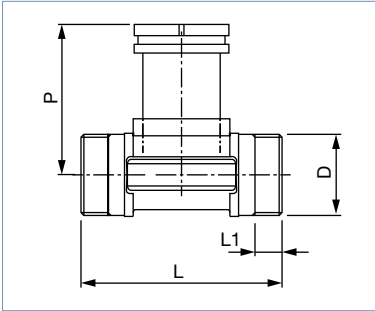

DN	P	L	L1	D	
				[Inch]	[mm]
06	75.3	90.0	14.0	G ½	–
08	75.3	90.0	14.0	G ½	–
15	80.3	84.0	11.5	G ¾	–
20	77.8	94.0	13.5	G 1	–
25	78.0	104.0	14.0	G 1¼	–
32	81.6	119.0	18.0	G 1½	–
40	85.4	129.0	19.0	–	M55x2
50	91.5	148.5	20.0	–	M64x2

According to SMS 1145 in stainless steel (316L - 1.4404)

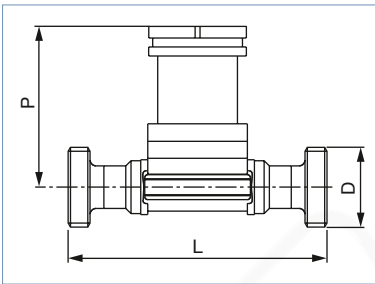

DN	P	L	D
25	77.8	130	Rd 40 x 1/6"
40	81.6	164	Rd 60 x 1/6"
50	85.4	173	Rd 70 x 1/6"

DTS 1000011768 EN Version: AR Status: RL (released | freigegeben | valide) printed: 27.05.2024

**Weld spigot connection**

**Note:**

- Dimensions in mm, unless otherwise stated
- For use with a flowmeter with short sensor
- Suitable from DN 32 for use with an analytical measuring device

According to EN ISO 1127/ISO 4200/DIN 11866 series B, SMS 3008 or BS 4825-1/ASME BPE/DIN 11866 series C in stainless steel (316L - 1.4404)

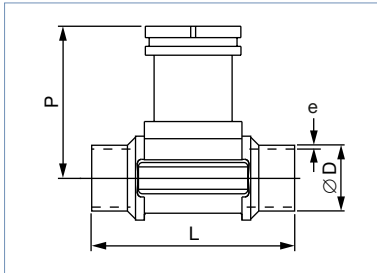

DN	P	Standard	L	øD	e
15	80.3	EN ISO 1127/ISO 4200/DIN 11866 Series B	84.0	21.30	1.60
	-	SMS 3008	-	-	-
	-	ASME BPE/DIN 11866 Series C	-	-	-
20	77.8	EN ISO 1127/ISO 4200/DIN 11866 Series B	94.0	26.9	1.60
	-	SMS 3008	-	-	-
	83.3	ASME BPE/DIN 11866 Series C	84.0	19.05	1.65
25	78.0	EN ISO 1127/ISO 4200/DIN 11866 Series B	104.0	33.70	2.00
	77.8	SMS 3008	94.0	25.00	1.20
	77.8	BS 4825-1/ASME BPE/DIN 11866 Series C	94.0	25.40	1.65
32	81.6	EN ISO 1127/ISO 4200/DIN 11866 Series B	119.0	42.40	2.00
	-	SMS 3008	-	-	-
	78.0	BS 4825-1/ASME BPE/DIN 11866 Series C	104.0	32.00	1.65
40	85.4	EN ISO 1127/ISO 4200/DIN 11866 Series B	129.0	48.30	2.00
	81.6	SMS 3008	119.0	38.00	1.20
	81.6	BS 4825-1/ASME BPE/DIN 11866 Series C	119.0	38.10	1.65
50	91.5	EN ISO 1127/ISO 4200/DIN 11866 Series B	148.5	60.30	2.60
	85.4	SMS 3008	128.0	51.00	1.20
	85.4	BS 4825-1/ASME BPE/DIN 11866 Series C	128.0	50.80	1.65
65	-	EN ISO 1127/ISO 4200/DIN 11866 Series B	-	-	-
	91.5	SMS 3008	147.0	63.50	1.60
	91.5	BS 4825-1/ASME BPE/DIN 11866 Series C	147.0	63.50	1.65

DTS 1000011768 EN Version: AR Status: RL (released | freigegeben | validé) printed: 27.05.2024





**Clamp connection**

**Note:**

- Dimensions in mm, unless otherwise stated
- For use with a flowmeter with short sensor
- Suitable from DN 32 for use with an analytical measuring device

According to DIN 32676 series B, SMS 3017<sup>1.)</sup> or BS 4825-3/ASME BPE<sup>1.)</sup> in stainless steel (316L - 1.4404)

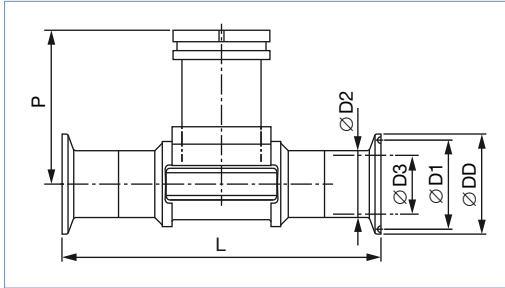

DN	P	Standard	L	øD	øD1	øD2	øD3
15	80.3	DIN 32676 Series B <sup>2.)</sup>	130	34.0	27.5	21.30	18.10
	-	SMS 3017	-	-	-	-	-
	-	ASME BPE	-	-	-	-	-
20	77.8	DIN 32676 Series B	150	50.5	43.5	26.90	23.70
	-	SMS 3017	-	-	-	-	-
	80.3	ASME BPE	119	25.0	19.6	19.05	15.75
25	78.0	DIN 32676 Series B	160	50.5	43.5	33.70	29.70
	77.8	SMS 3017	129	50.5	43.5	25.00	22.60
	77.8	BS 4825-3/ASME BPE	129	50.5	43.5	25.40	22.10
32	81.6	DIN 32676 Series B	180	50.5	43.5	42.40	38.40
	-	SMS 3017	-	-	-	-	-
	-	BS 4825-3/ASME BPE	-	-	-	-	-
40	85.4	DIN 32676 Series B	200	64.0	56.5	48.30	44.30
	81.6	SMS 3017	161	50.5	43.5	38.00	35.60
	81.6	BS 4825-3/ASME BPE	161	50.5	43.5	38.10	34.80
50	91.5	DIN 32676 Series B	230	77.5	70.5	60.30	55.10
	85.4	SMS 3017	192	64.0	56.5	51.00	48.60
	85.4	BS 4825-3/ASME BPE	192	64.0	56.5	50.80	47.50
65	-	DIN 32676 Series B	-	-	-	-	-
	91.5	SMS 3017	216	77.5	70.5	63.50	60.30
	91.5	BS 4825-3/ASME BPE	216	77.5	70.5	63.50	60.20

1.) Available with internal surface finish Ra < 0.8 µm  
 2.) Similar to DIN 32676 series B but with 34.0 mm clamp connection

**Flange connection**

**Note:**

- Dimensions in mm, unless otherwise stated
- For use with a flowmeter with short sensor
- Suitable from DN 32 for use with an analytical measuring device

According to EN1092-1/B1/PN 16 or ANSI B16-5 in stainless steel (316L - 1.4404)

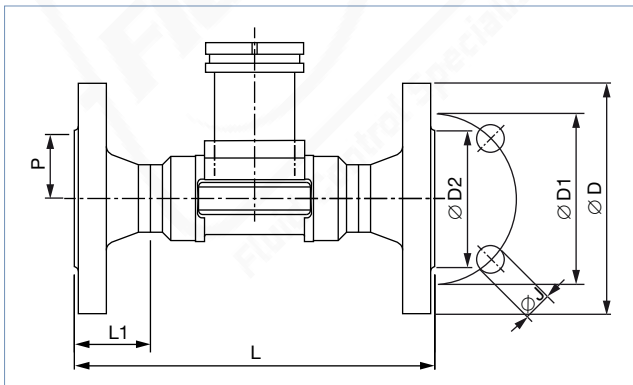

DN	P	Standard	L	L1	øD	øD1	øD2	øJ
15	80.3	EN	130	23.5	95.0	65.0	45.0	4x14.0
		ANSI	130	-	89.0	60.3	34.9	4x15.8
20	77.8	EN	150	28.5	105.0	75.0	58.0	4x14.0
		ANSI	150	-	99.0	69.8	42.9	4x15.8
25	78.0	EN	160	28.5	115.0	85.0	68.0	4x14.0
		ANSI	160	-	108.0	79.4	50.8	4x15.8
32	81.6	EN	180	31.0	140.0	100.0	78.0	4x18.0
		ANSI	180	-	117.0	88.9	63.5	4x15.8
40	85.4	EN	200	36.0	150.0	110.0	88.0	4x18.0
		ANSI	200	-	127.0	98.4	73.0	4x15.8
50	91.5	EN	230	41.0	165.0	125.0	102.0	4x18.0
		ANSI	230	-	152.0	120.6	92.1	4x19.0

DTS 1000011768 EN Version: AR Status: RL (released | freigegeben | valide) printed: 27.05.2024

### 4.2. Plastic T-fitting for measuring device with G 2" process connection

True union connection with nut and solvent/fusion socket

**Note:**

- Dimensions in mm, unless otherwise stated
- For use with a flowmeter with short sensor
- Suitable for use with an analytical measuring device. Please note that the fittings DN 15...DN 25 to be used for the analytical measurement differ from those for the flow measurement.

According to DIN 8063, ASTM D 1785/76 or JIS K in PVC, DIN 16962 in PP or ISO 10931 in PVDF

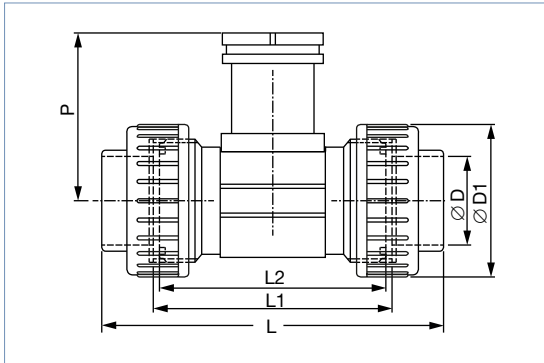

DN	P	Standard	L	L1	L2	ØD	ØD1
15	80.4	DIN/ISO	128.0	96	90	20.00	43
		ASTM	130.0			21.30	
		JIS	129.0			18.40	
15 <sup>1.)</sup>	81.4	DIN/ISO	148.0	116	110	20.00	74
20	77.8	DIN/ISO	144.0	106	100	25.00	53
		ASTM	145.6			26.70	
		JIS	145.0			26.45	
20 <sup>1.)</sup>	81.4	DIN/ISO	154.0	116	110	25.00	74
25	78.0	DIN/ISO	160.0	116	110	32.00	60
		ASTM	161.4			33.40	
		JIS	161.0			32.55	
25 <sup>1.)</sup>	81.4	DIN/ISO	160.0	116	110	32.00	74
32	81.4	DIN/ISO	168.0	116	110	40.00	74
		ASTM	170.0			42.20	
		JIS	169.0			38.60	
40	85.2	DIN/ISO	188.0	127	120	50.00	83
		ASTM	190.2			48.30	
		JIS	190.0			48.70	
50	91.5	DIN/ISO	212.0	136	130	63.00	103
		ASTM	213.6			60.30	
		JIS	213.0			60.80	

1.) Fitting for analytical measurement

#### External thread connection

**Note:**

- Dimensions in mm, unless otherwise stated
- For use with a flowmeter with short sensor
- Not suitable for use with an analytical measuring device

According to G in PVC (only DN 06 and DN 08)

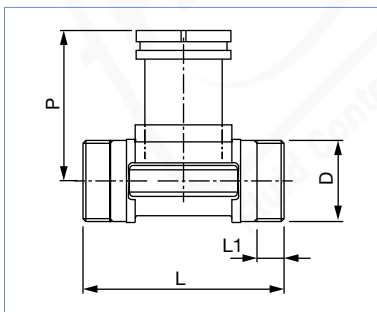

DN	P	L	L1	D
				[Inch]
06	75.3	90.0	14.0	G ½
08	75.3	90.0	14.0	G ½

DTS 1000011768 EN Version: AR Status: RL (released | freigegeben | valide) printed: 27.05.2024

**Solvent/fusion spigot connection**

**Note:**

- Dimensions in mm, unless otherwise stated
- For use with a flowmeter with short sensor
- Suitable from DN 32 for use with an analytical measuring device

According to DIN 8063 in PVC, DIN 16962 in PP or ISO 10931 in PVDF

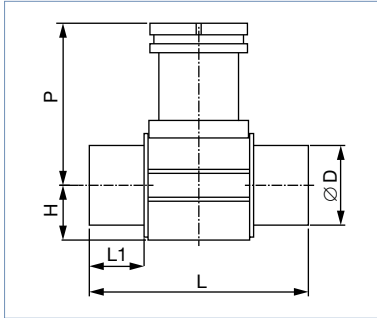

DN	P	Standard	H	L	L1	øD
15	80.4	DIN 8063	17.5	90	16.5	20
		DIN 16962		85	14.0	
		DIN 10931		85	14.0	
20	77.8	DIN 8063	17.5	100	20.0	25
		DIN 16962		92	16.0	
		DIN 10931		92	16.0	
25	78.0	DIN 8063	21.5	110	23.0	32
		DIN 16962		95	18.0	
		DIN 10931		95	18.0	
32	81.4	DIN 8063	27.5	110	27.5	40
		DIN 16962		100	20.0	
		DIN 10931		100	20.0	
40	85.2	DIN 8063	31.5	120	30.0	50
		DIN 16962		106	23.0	
		DIN 10931		106	23.0	
50	91.5	DIN 8063	39.5	130	37.0	63
		DIN 16962		110	27.0	
		DIN 10931		110	27.0	

**4.3. Straight connection for measuring device with G 2" process connection**

**Weld spigot connection with radius**

**Note:**

- Dimensions in mm, unless otherwise stated
- For use with a flowmeter with short sensor for DN 50...DN 200 and with long sensor for DN 250...DN 350
- Only suitable from DN 50...DN 200 for use with an analytical measuring device

In stainless steel (316L - 1.4404)

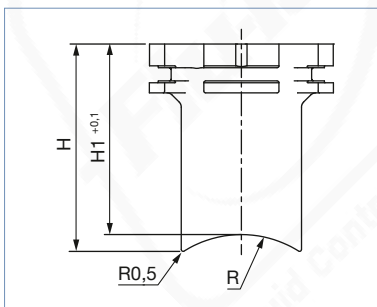

DN	H	H1	R
50	61.6	56.6	30.2
65	58.6	54.5	36.7
80	56.4	53.1	44.5
100	53.2	50.7	57.2
125	50.3	48.2	70.7
150	47.4	45.7	84.2
200	42.3	41.0	109.6
250	74.7	73.6	136.6
300	68.7	67.8	162.0
350	64.7	63.9	177.8

DTS 1000011768 EN Version: AR Status: RL (released | freigegeben | valide) printed: 27.05.2024

**Fusion spigot connection**

**Note:**

- Dimensions in mm, unless otherwise stated
- For use with a flowmeter with short sensor for DN 65...DN 100 and with long sensor for DN 125...DN 400
- Only suitable for DN 65...DN 100 for use with an analytical measuring device

In PE, PP or PVDF

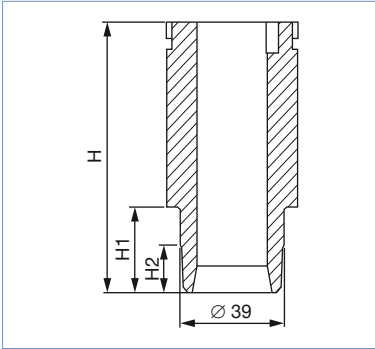

DN	H	Materials	H1	H2
65	72.5	PE	13.0	-
		PP	13.0	-
		PVDF	10.4	-
80	72.5	PE	15.6	-
		PP	15.6	-
		PVDF	12.5	-
100	72.5	PE	19.0	5.0
		PP	19.0	5.0
		PVDF	15.2	6.0
125	102.0	PE	24.2	8.0
		PP	-	-
		PVDF	-	-
150	102.0	PE	27.7	10.0
		PP	27.7	10.0
		PVDF	-	-
200	102.0	PE	38.9	16.0
		PP	38.9	16.0
		PVDF	-	-
250	102.0	PE	48.4	21.0
		PP	48.4	21.0
		PVDF	-	-
300	102.0	PE	54.5	24.0
		PP	54.5	24.0
		PVDF	-	-
350	102.0	PE	61.3	28.0
		PP	61.3	28.0
		PVDF	-	-
400	102.0	PE	69.1	31.5
		PP	-	-
		PVDF	-	-

**Screw-on spigot connection**

**Note:**

- Dimensions in mm, unless otherwise stated
- Only for use with a flowmeter with long sensor

In PVC, PP, PE

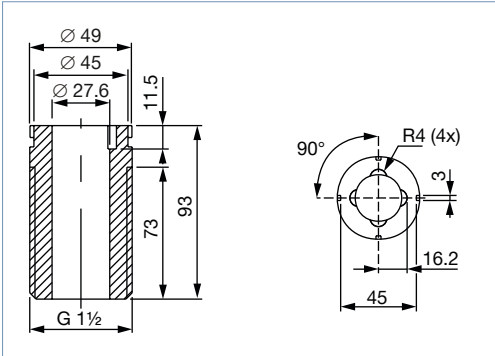

**4.4. Saddle for flowmeter with G 2" process connection**

**Note:**

- Dimensions in mm, unless otherwise stated
- Only for use with a flowmeter with long sensor

Body and adapter in PP, seal in EPDM, reinforcing ring in stainless steel

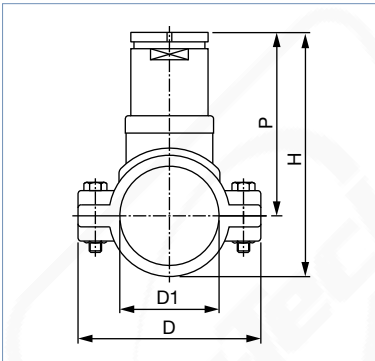

DN	P	H	D	D1
50	116.0	155	116	63
65	115.0	160	129	75
80	119.0	171	144	90
100	124.0	187	166	110
110	120.0	191	181	125
125	127.0	205	196	140
150	137.0	225	216	160
180	161.0	271	266	200
200	173.0	291	290	225

DTS 1000011768 EN Version: AR Status: RL (released | freigegeben | valide) printed: 27.05.2024

**4.5. Measuring chamber for analytical measuring device with G 2" process connection**

**Note:**

Dimensions in mm, unless otherwise stated

In stainless steel 316L - 1.4404, G 1/2" pipe connection

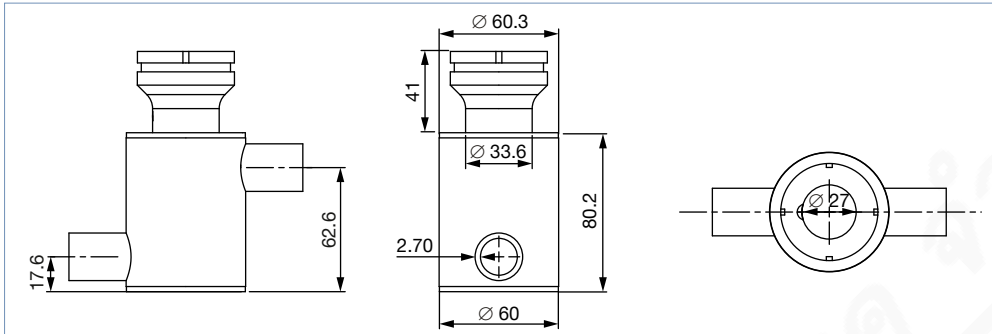

**4.6. T-fitting for flowmeter with clamp process connection**

**Weld spigot connection**

**Note:**

Dimensions in mm, unless otherwise stated

According to SMS 3008, BS 4825-1/ASME BPE/DIN 11866 Series C or DIN 11850 Series 2/DIN 11866 Series A/DIN EN 10357 Series A in stainless steel 316L

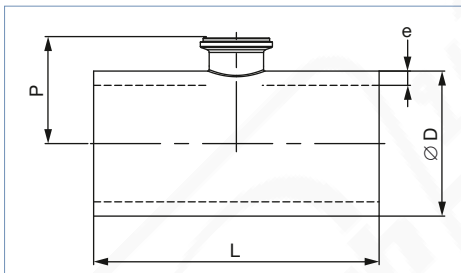

DN	P	Standard	L	øD	e
40	42.5	SMS 3008	140.0	38.0	1.20
	43.7	ASME BPE/DIN 11866 Series C	120.6	38.1	1.65
	44.3	DIN 11850 Series 2/DIN 11866 Series A/ DIN EN 10357 Series A	120.0	41.0	1.50
50	49.3	SMS 3008	164.0	51.0	1.20
	50.6	BS 4825-1/ASME BPE/DIN 11866 Series C	146.0	50.8	1.65
	50.8	DIN 11850 Series 2/DIN 11866 Series A/ DIN EN 10357 Series A	160.0	53.0	2.00
65	54.4	SMS 3008	210.0	63.5	1.60
	55.4	BS 4825-1/ASME BPE/DIN 11866 Series C	158.8	63.5	1.65
	59.6	DIN 11850 Series 2/DIN 11866 Series A/ DIN EN 10357 Series A	210.0	70.0	2.00
80	60.7	SMS 3008	220.0	76.1	1.60
	62.0	BS 4825-1/ASME BPE/DIN 11866 Series C	171.5	76.2	1.65
	67.3	DIN 11850 Series 2/DIN 11866 Series A/ DIN EN 10357 Series A	260.0	85.0	2.00
100	73.8	BS 4825-1/ASME BPE/DIN 11866 Series C	209.6	101.6	2.11
	77.1	DIN 11850 Series 2/DIN 11866 Series A/ DIN EN 10357 Series A	310.0	104.0	2.00

DTS 1000011768 EN Version: AR Status: RL (released | freigegeben | valide) printed: 27.05.2024

### 4.7. Straight connection for flowmeter with clamp process connection

#### Weld spigot connection

**Note:**

Dimensions in mm, unless otherwise stated

According to SMS 3008, DIN 11850 Series 2/DIN 11866 Series A/DIN EN 10357 Series A in stainless steel 316L

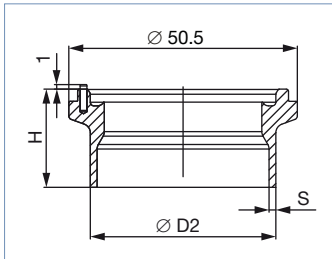

DN	Standard	H	S	D2
40	SMS 3008	21.7	1.2	38
	DIN 11850 Series 2/DIN 11866 Series A/DIN EN 10357 Series A	21.7	1.5	41
50	SMS 3008	21.7	1.2	38
	DIN 11850 Series 2/DIN 11866 Series A/DIN EN 10357 Series A	21.7	1.5	41
65	SMS 3008	19.7	1.2	38
	DIN 11850 Series 2/DIN 11866 Series A/DIN EN 10357 Series A	21.7	1.5	41
80	SMS 3008	19.7	1.2	38
	DIN 11850 Series 2/DIN 11866 Series A/DIN EN 10357 Series A	21.7	1.5	41
100	DIN 11850 Series 2/DIN 11866 Series A/DIN EN 10357 Series A	19.7	1.5	41

According to BS 4825-1/ASME BPE/DIN 11866 Series C in stainless steel 316L

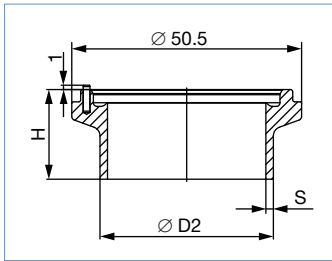

DN	Standard	H	S	D2
40	ASME BPE/DIN 11866 Series C	23.7	1.65	38.1
50	BS 4825-1/ASME BPE/DIN 11866 Series C	23.7	1.65	38.1
65	BS 4825-1/ASME BPE/DIN 11866 Series C	19.7	1.65	38.1
80	BS 4825-1/ASME BPE/DIN 11866 Series C	19.7	1.65	38.1
100	BS 4825-1/ASME BPE/DIN 11866 Series C	19.7	1.65	38.1

## 5. Performance specifications

### 5.1. Pressure temperature diagram

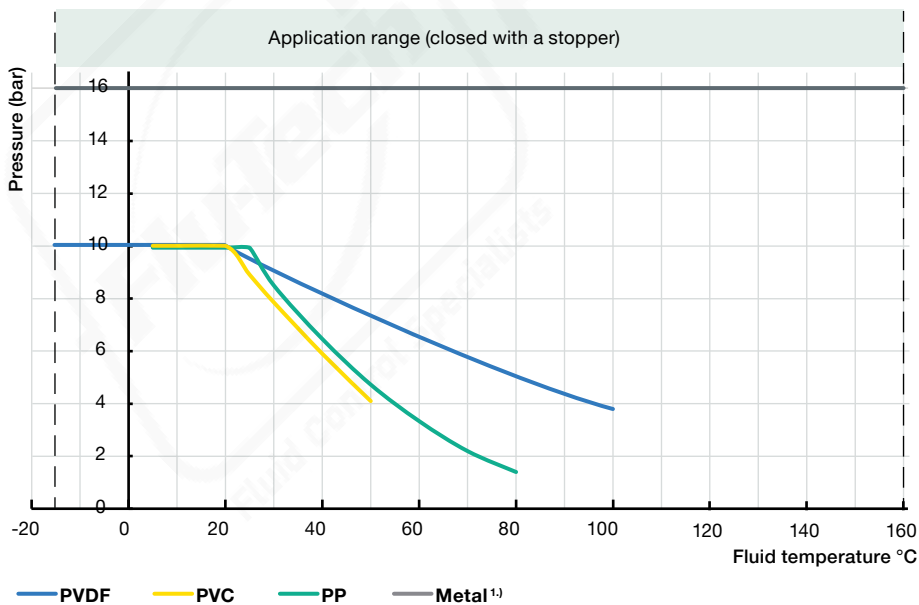

1.) Excepted fitting DN 100 (- 15...+ 160 °C, PN 10) with clamp measuring device connection

## 6. Product installation

### 6.1. Installation notes

#### Flow measurement

**Note:**

The fitting combined with a measuring device is not suitable for use in gaseous media and steam.

Minimum straight distances upstream and downstream of the sensor must be observed. These stabilizing distances depend on the pipe's design. Increasing these distances or installing a flow conditioner may be necessary to obtain the best accuracy. For more information, refer to EN ISO 5167-1.

EN ISO 5167-1 specifies the straight inlet and outlet distances that must be complied with when installing fittings in pipe lines in order to achieve calm flow conditions. The most commonly used elements that could lead to turbulence in the flow are shown below. The related minimum inlet and outlet distances that ensure a calm flow are also specified.

Make sure that the measuring conditions at the point of measurement are calm and problem-free.

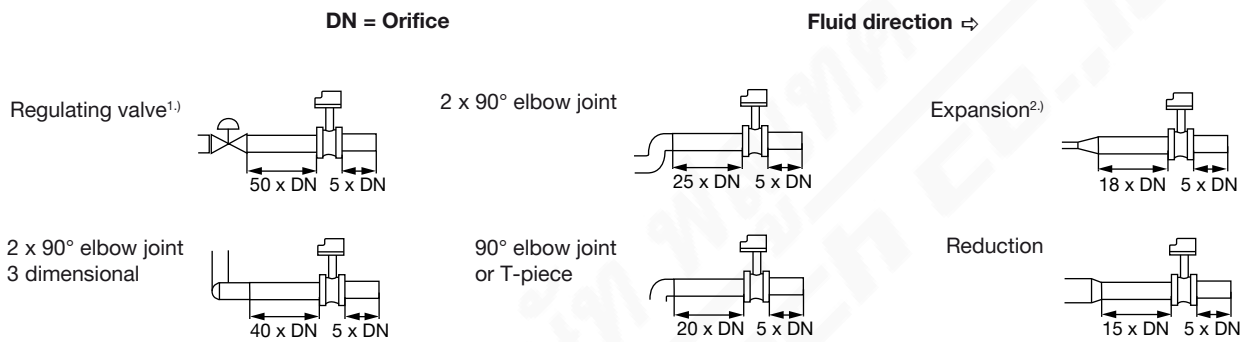

1.) If the valve cannot be mounted after the measuring device, the minimal distances have to be respected.  
 2.) If an expansion cannot be avoided, the minimal distances have to be respected.  
 Please note minimum flow velocity

The complete measuring device can be installed in either horizontal or vertical pipes, but following additional conditions should be respected:

- The pipe always has to be filled with fluid at all times near the device.
- The pipe design must be such that no air bubbles or cavitation can form within the medium near the device at any time.

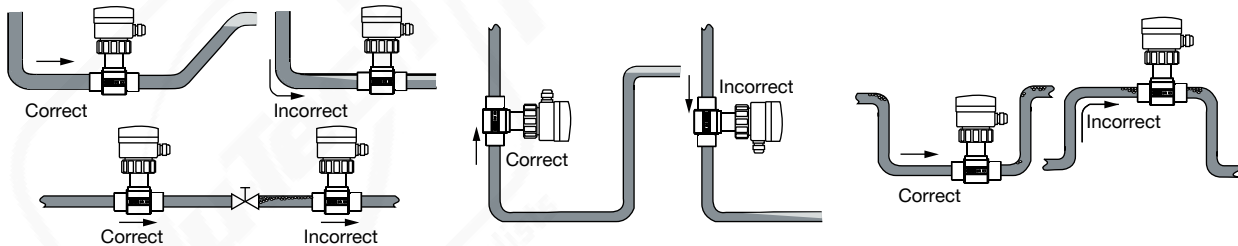

Pressure and temperature ratings must be respected according to the selected fitting material. The suitable pipe size is selected using the diagram in the chapter "Nominal size selection" of the fitting, see chapter "6.2. Selection of the nominal diameter" on page 17.

#### Analytical measurement

For these analytical measurements, we recommended a "U"- form bypass installation to ensure that the sensor does not dry out and can also be calibrated without stopping the whole process or to use the special designed measuring chamber. The specially designed measuring chamber enables to install all pH, ORP, conductivity measuring devices in all pipe systems, either directly in the main flow or in a by-pass line. Additionally, the electrode is always kept wet and is easily isolated from the main flow for calibration purposes.

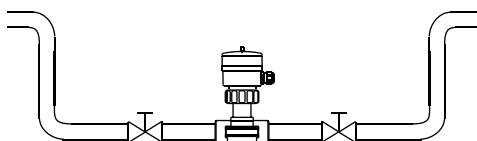

DTS 1000011768 EN Version: AR Status: RL (released | freigegeben | valide) printed: 27.05.2024



### 6.2. Selection of the nominal diameter

The following graph is used to determine the appropriate DN of the pipe and fitting for the application, according to the fluid velocity and the flow rate. On the chart, the intersection of flow velocity and flow rate gives the appropriate diameter.

**Note:**

- For the fittings listed below, the corresponding nominal size in the bracket must be used:
  - External threads acc. to SMS 1145
  - Weld ends acc. to SMS 3008, BS4825-1/ASME BPE/DIN 11866 series C or DIN 11850 series 2/DIN 11866 series A/ DIN EN 10357 series A
  - Clamp acc. to SMS 3017, BS 4825-3/ASME BPE or DIN 32676 series A.
- For all other fittings, the corresponding nominal diameter without bracket applies.

**Example 1:**

- Nominal flow: 10 m<sup>3</sup>/h
  - Optimal flow rate: 2...3 m/s
- Result: Select a pipe size of DN 40

Not recommended  
 - - - - if used with Type 8041/8045  
 - - - - if used with Type 8020, 8025 or 8026

**Example 2 with external threads acc. to SMS 1145:**

- Nominal flow: 10 m<sup>3</sup>/h
  - Optimal flow rate: 2...3 m/s
- Result: Select a pipe size of DN 50

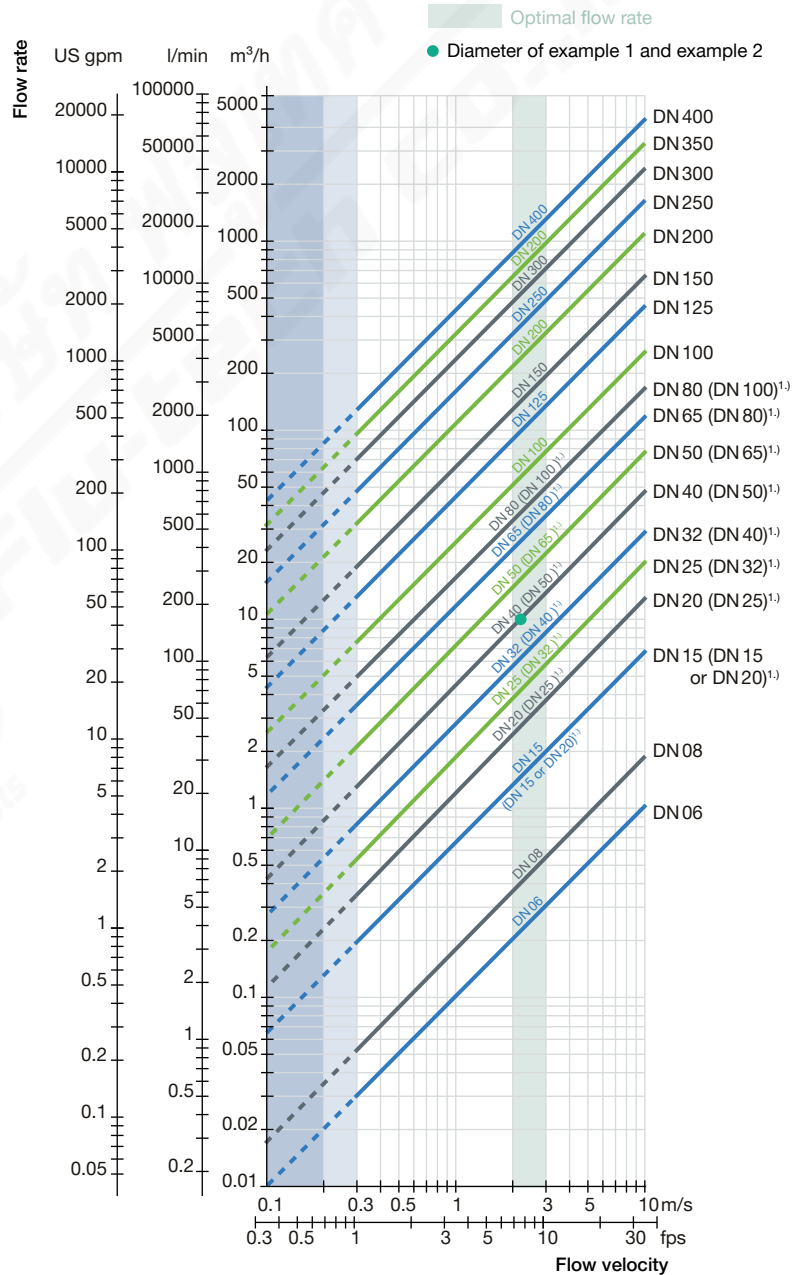

1.) See note at the beginning of this chapter.

DTS 1000011768 EN Version: AR Status: RL (released | freigegeben | validé) printed: 27.05.2024

## 7. Product accessories

**Note:**

Since March 2012, the Type S020 fittings in DN 15 and DN 20 have been available in 2 variants with different K factors. Further information can be found in the user manual in the K factor chapter, see **Type S020** ▶.

The 2nd variant is identified by the “v2” marking. This “v2” marking can be found:

- on the bottom of the DN 15 or DN 20 fitting in plastic

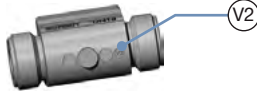

- on the side of the DN 15 or DN 20 fitting in metal

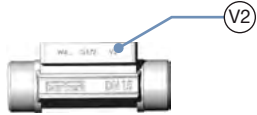

Accessory	No.	Description
	1	O-ring set for metal fitting
	2	O-ring set <sup>1.)</sup> for plastic fitting

1.) Depends on sensor armature variant: flat seal to use for armature with groove (previous variant, no longer available), O-ring seal to use for armature with chamfer (variant “v2”)

DTS 1000011768 EN Version: AR Status: RL (released | freigegeben | validé) printed: 27.05.2024

## 8. Networking and combination with other Bürkert products

### 8.1. Fitting for measuring device with G 2" process connection

Example:



Type S020

Flowmeter				
<b>Type 8020</b> ▶ Insertion flowmeter with paddle wheel	<b>Type 8025</b> ▶ Insertion flowmeter or batch controller with paddle wheel	<b>Type 8026</b> ▶ Insertion flowmeter with paddle wheel, ELEMENT design	<b>Type 8041</b> ▶ Magnetic inductive Insertion flowmeter	<b>Type 8045</b> ▶ Magnetic inductive Insertion flowmeter
Analytical measuring device				
<b>Type 8200</b> ▶ + <b>Type 8203</b> ▶ Armatures and pH- or ORP probes	<b>Type 8220</b> ▶ Conductivity sensor	<b>Type 8228</b> ▶ Conductivity sensor, ELEMENT design		
Transmitter				
<b>Type 8619</b> ▶ multiCELL - transmitter/controller	<b>Type 8025</b> ▶ Flow transmitter (only for flowmeter)	<b>Type 8611</b> ▶ eCONTROL - Universal controller panel, wall or rail-mounting variant		

DTS 1000011768 EN Version: AR Status: RL (released | freigegeben | valide) printed: 27.05.2024

8.2. Fitting for for flowmeter with clamp process connection

Example:

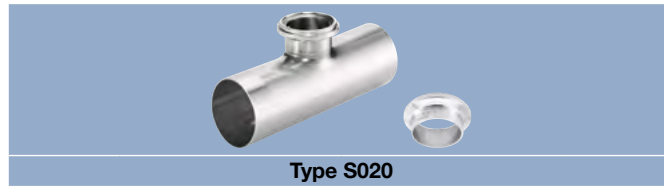

Type S020

Flowmeter



Type 8041 ▶

Magnetic inductive Insertion flowmeter



Type 8045 ▶

Magnetic inductive Insertion flowmeter

Transmitter



Type 8619 ▶

multiCELL - transmitter/controller



Type 8025 ▶

Flow transmitter



Type 8611 ▶

eCONTROL - Universal controller panel, wall or rail-mounting variant

DTS 1000011768 EN Version: AR Status: RL (released | freigegeben | validé) printed: 27.05.2024

### 8.3. Combination of the S020 with a measuring device for flow rate, pH or ORP, conductivity measurement

		DN 06	DN 32	DN 50	DN 65	DN 100	DN 200	DN 350	DN 400
Available Type S020 fittings DN	For device with G 2" connection								
	T-fitting	[Bar]							
	Welding socket			[Bar]					
	Fusion spigot			[Bar]					
	Screw-on spigot					[Bar] For flow measurement			
Saddle			[Bar] For flow measurement						
Device for	For device with clamp connection								
	T-fitting or welding socket			[Bar]					
	Flow rate measurement Type 8020, 8025, 8026, 8041 and 8045 with G 2" process connection								
Type 8041 and 8045 with clamp process connection			[Bar]						
Analytical measurement pH or ORP: Type 8200/8203 Conductivity: Type 8220, 8228			[Bar] 3.)						

- 1.) DN 20 fittings according to the following standards cannot be used with flowmeters Type 8020, Type 8025 and Type 8026. DN 32 fittings according to the following standards cannot be used with analytical measuring devices Type 8200/8203, Type 8220 and Type 8228. Standards: fittings with external threads according to SMS 1145, weld ends according to SMS 3008, BS 4825-1/ASME BPE/DIN 11866 series C or DIN 11850 series 2/DIN 11866 series A/DIN EN 10357 series A, Clamp according to SMS 3017, BS 4825-3/ASME BPE, DIN 32676 series A.
- 2.) See the note for the use of the fitting in chapter "4. Dimensions" on page 6
- 3.) Only use plastic fittings with true union process connection in analytical variant, with nut and solvent/fusion socket according to DIN 8063 (PVC), to DIN 16962 (PP) or to ISO 10931 (PVDF), other materials are available on request.

For further details about the various combination possibilities (measuring device and fitting), please **consult the measuring device related data sheet**.

## 9. Ordering information

### 9.1. Bürkert eShop



#### Bürkert eShop – Easy ordering and quick delivery

You want to find your desired Bürkert product or spare part quickly and order directly? Our online shop is available for you 24/7. Sign up and enjoy all the benefits.

[Order online now](#)

### 9.2. Bürkert product filter



#### Bürkert product filter – Get quickly to the right product

You want to select products comfortably based on your technical requirements? Use the Bürkert product filter and find suitable articles for your application quickly and easily.

[Try out our product filter](#)

9.3. Ordering chart

Metal T-fitting DN 06...DN 65 for measuring device with G 2" process connection

Standard	Article no.								
	DN 06 - 1/2"	DN 08 - 1/2"	DN 15	DN 20	DN 25	DN 32	DN 40	DN 50	DN 65
<b>Brass body &amp; stainless steel adapter - Fluid temperature max. 160 °C, PN 16</b>									
<b>FKM seal</b>									
<b>Internal thread connection</b>									
G	-	-	428712 ₺	428713 ₺	428714 ₺	428715 ₺	428716 ₺	428717 ₺	-
NPT	-	-	428718 ₺	428719 ₺	428720 ₺	428721 ₺	428722 ₺	428723 ₺	-
Rc	-	-	428724 ₺	428725 ₺	428726 ₺	428727 ₺	428728 ₺	428729 ₺	-
<b>External thread connection</b>									
G	-	-	428730 ₺	428731 ₺	428732 ₺	428733 ₺	428734 ₺	428735 ₺	-
<b>Stainless steel body &amp; stainless steel adapter - Fluid temperature max. 160 °C, PN 16</b>									
<b>FKM seal</b>									
<b>Internal thread connection</b>									
G	-	-	428736 ₺	428737 ₺	428738 ₺	428739 ₺	428740 ₺	428741 ₺	-
NPT	-	-	428742 ₺	428743 ₺	428744 ₺	428745 ₺	428746 ₺	428747 ₺	-
Rc	-	-	428748 ₺	428749 ₺	428750 ₺	428751 ₺	428752 ₺	428753 ₺	-
<b>External thread connection</b>									
G	552434 ₺	552432 ₺	428754 ₺	428755 ₺	428756 ₺	428757 ₺	428758 ₺	428759 ₺	-
<b>Weld spigot connection</b>									
EN ISO 1127/ISO 4200/ DIN 11866 series B	-	-	428760 ₺	428761 ₺	428762 ₺	428763 ₺	428764 ₺	428765 ₺	-
<b>Clamp connection</b>									
DIN 32676 series B	-	-	428766 ₺ 2.)	428767 ₺	428768 ₺	428769 ₺	428770 ₺	428771 ₺	-
<b>Flange connection</b>									
EN 1092-1/B1/PN 16	-	-	428772 ₺	428773 ₺	428774 ₺	428775 ₺	428776 ₺	428777 ₺	-
ANSI B16-5	-	-	428778 ₺	428779 ₺	428780 ₺	428781 ₺	428782 ₺	428783 ₺	-
<b>EPDM seal</b>									
<b>External thread connection</b>									
SMS 1145	-	-	-	-	443317 ₺	-	443318 ₺	443319 ₺	-
<b>Weld spigot connection</b>									
SMS 3008	-	-	-	-	443309 ₺	-	443310 ₺	443311 ₺	443944 ₺ 4.)
BS 4825-1/ASME BPE/ DIN 11866 series C	-	-	-	443734 ₺ 3.)	443735 ₺	443736 ₺	443942 ₺	443943 ₺	443944 ₺
<b>Clamp connection</b>									
SMS 3017	-	-	-	-	443313 ₺	-	443314 ₺	443315 ₺	443969 ₺ 4.)
SMS 3017 <sup>1.)</sup>	-	-	-	-	443957 ₺	-	443958 ₺	443959 ₺	443974 ₺ 4.)
BS 4825-3/ ASME BPE	-	-	-	443965 ₺ 3.)	443966 ₺	-	443967 ₺	443968 ₺	443969 ₺
BS 4825-3/ ASME BPE <sup>1.)</sup>	-	-	-	443970 ₺	443971 ₺	-	443972 ₺	443973 ₺	443974 ₺

1.) Internal surface finish Ra < 0.8 µm  
 2.) Refer to clamp with D dimensions of 34 mm (see chapter "Clamp connection" on page 9)  
 3.) DN 20 (¾") only available in ASME BPE  
 4.) Refer to ASME BPE

Further variants on request	
	<b>Process connection</b> <ul style="list-style-type: none"> <li>Weld spigot connection according to DIN 11850 series 2/DIN 11866 series A/ DIN EN 10357 series A</li> <li>Clamp according to DIN 32676 series A</li> </ul>

Plastic T-fitting DN 06...DN 65 for measuring device with G 2" process connection

Standard	Article no.								
	DN 06 -1/2"	DN 08 -1/2"	DN 15	DN 20	DN 25	DN 32	DN 40	DN 50	DN 65
<b>PVC body &amp; PVC adapter - Fluid temperature max. 50 °C, PN 10</b>									
<b>FKM seal</b>									
<b>True union connection with nut and solvent socket</b>									
DIN 8063	-	-	428670 ☒	428671 ☒	428672 ☒	428673 ☒	428674 ☒	428675 ☒	-
ASTM D 1785/76	-	-	428682 ☒	428683 ☒	428684 ☒	428685 ☒	428686 ☒	428687 ☒	-
JIS K	-	-	429078 ☒	429079 ☒	429080 ☒	429081 ☒	429082 ☒	429083 ☒	-
<b>External thread connection</b>									
G	552561 ☒	550062 ☒	-	-	-	-	-	-	-
<b>Solvent spigot connection</b>									
DIN 8063	-	-	428676 ☒	428677 ☒	428678 ☒	428679 ☒	428680 ☒	428681 ☒	-
<b>Analytical variant - True union connection with nut and solvent socket</b>									
DIN 8063	-	-	430837 ☒	430838 ☒	430839 ☒	428673 ☒	428674 ☒	428675 ☒	-
<b>PP body &amp; PP adapter - Fluid temperature max. 80 °C, PN 10</b>									
<b>FKM seal</b>									
<b>True union connection with nut and fusion socket</b>									
DIN 16962	-	-	428688 ☒	428689 ☒	428690 ☒	428691 ☒	428692 ☒	428693 ☒	-
<b>Fusion spigot connection</b>									
DIN 16962	-	-	428694 ☒	428695 ☒	428696 ☒	428697 ☒	428698 ☒	428699 ☒	-
<b>Analytical variant - True union connection with nut and fusion socket</b>									
DIN 16962	-	-	430840 ☒	430841 ☒	430842 ☒	428691 ☒	428692 ☒	428693 ☒	-
<b>PVDF body &amp; PVDF adapter - Fluid temperature max. 100 °C, PN 10</b>									
<b>FKM seal</b>									
<b>True union connection with nut and fusion socket</b>									
ISO 10931	-	-	428700 ☒	428701 ☒	428702 ☒	428703 ☒	428704 ☒	428705 ☒	-
<b>Fusion spigot connection</b>									
ISO 10931	-	-	428706 ☒	428707 ☒	428708 ☒	428709 ☒	428710 ☒	428711 ☒	-
<b>Analytical variant - True union connection with nut and fusion socket</b>									
ISO 10931	-	-	430843 ☒	430844 ☒	430845 ☒	428703 ☒	428704 ☒	428705 ☒	-

DTS 1000011768 EN Version: AR Status: RL (released | freigegeben | validé) printed: 27.05.2024

**Straight connection DN 50...DN 400 for measuring device with G 2" process connection**

Article no.										
DN 50	DN 65	DN 80	DN 100	DN 125	DN 150	DN 200	DN 250	DN 300	DN 350	DN 400
<b>Weld/fusion spigot connection</b>										
<b>Stainless steel - with radius - Fluid temperature max. 160 °C, PN 16</b>										
418111	418112	418113	418114	418115	418116	418117	418756	420070	416637	-
<b>PE - Fluid temperature max. 70 °C, PN 10</b>										
-	418642	418643	418644	418590	418645	418646	418647	418648	418649	418598
<b>Analytical variant - PE - Fluid temperature max. 70 °C, PN 10</b>										
-	418644	418644	418644	-	-	-	-	-	-	-
<b>PP - Fluid temperature max. 80 °C, PN 10</b>										
-	418650	418651	418652	-	418653	418654	418655	418656	418657	-
<b>Analytical variant - PP - Fluid temperature max. 80 °C, PN 10</b>										
-	418652	418652	418652	-	-	-	-	-	-	-
<b>PVDF - Fluid temperature max. 100 °C, PN 10</b>										
-	418658	418659	418660	-	-	-	-	-	-	-
<b>Analytical variant - PVDF - Fluid temperature max. 100 °C, PN 10</b>										
-	418660	418660	418660	-	-	-	-	-	-	-
<b>Screw-on spigot connection</b>										
<b>PVC - Fluid temperature max. 50 °C, PN 10</b>										
-	-	-	418170	418170	418170	418170	-	-	-	-
<b>PE - Fluid temperature max. 70 °C, PN 10</b>										
-	-	-	436489	436489	436489	436489	436489	436489	436489	436489
<b>PP - Fluid temperature max. 50 °C, PN 10</b>										
-	-	-	436488	436488	436488	436488	436488	436488	436488	436488

**Saddle for flowmeter with G 2" process connection**

Seal	Article no.									
	DN 50	DN 65	DN 80	DN 100	DN 110	DN 125	DN 150	DN 180	DN 200	
<b>PP body and PP adapter - Fluid temperature max. 60 °C, PN 10 (for PVC or PP pipe)</b>										
EPDM	425138	425139	425140	425141	425142	425143	425144	433873	425416	

**Measuring chamber for analytical measuring device with G 2" process connection**

Description	Article no.
Measuring chamber in stainless steel 316L - 1.4404 (other material on request)	553611

**T-fitting DN 32...DN 100 for flowmeter Type 8041/8045 with clamp process connection**

Standard	Article no.					
	DN 32 PN 16	DN 40 PN 16	DN 50 PN 16	DN 65 PN 16	DN 80 PN 16	DN 100 PN 10
<b>Stainless steel - Fluid temperature max. 160 °C</b>						
SMS 3008	-	564915	564916	564917	564918	1.)
BS 4825-1/ASME BPE/DIN 11866 series C	-	564920	564921	564922	564923	564924
DIN 11850 series 2/DIN 11866 series A/DIN EN 10357 series A	-	564925	564926	564927	564928	564929

DTS 1000011768 EN Version: AR Status: RL (released | freigegeben | valide) printed: 27.05.2024



**Straight connection DN 32...DN 100 for flowmeter Type 8041/8045 with clamp process connection**

Standard	Article no.					
	DN 32 PN 16	DN 40 PN 16	DN 50 PN 16	DN 65 PN 16	DN 80 PN 16	DN 100 PN 10
<b>Stainless steel - Fluid temperature max. 160 °C</b>						
SMS 3008	-	564696	564696	564697	564697	1.)
BS 4825-1/ASME BPE/DIN 11866 series C	-	564698	564698	564699	564699	564699
DIN 11850 series 2/DIN 11866 series A/DIN EN 10357 series A	-	565069	565069	565069	565069	565390

1.) Refer to BS 4825-1/ASME BPE/DIN 11866 series C or to DIN 11850 series 2/DIN 11866 series A/DIN EN 10357 series A.

**Further variants on request**

**Process connection**  
According to EN ISO 1127/ISO 4200/DIN 11866 series B (DN 32...DN 80)

**9.4. Ordering chart accessories**

**Accessories for all variants**

Description	Article no.
<b>Approvals/Certificates</b>	
3 points flow calibration certificate <sup>1.)</sup>	550676
Inspection certificate 3.1 (according to EN-ISO 10204)	803723
Test report 2.2 (according to EN-ISO 10204)	803722
Certification of Conformity for the surface Quality (according to DIN4762, DIN4768, ISO/4287/1)	804175
FDA declaration of conformity	803724

1.) S020 in combination with the inserted flow measuring device inserted, only for DN ≤ 200

**Accessories for fitting for measuring device with G 2" process connection**

**Note:**





Since March 2012, the Type S020 fittings in DN 15 and DN 20 have been available in 2 variants with different K factors. The 2nd variant is identified by the "v2" marking.

See chapter "7. Product accessories" on page 18.

Accessory	Description	Article no.
<b>Stopper with ring, union nut and O-ring</b>		
	Stainless steel	438755
	PVC	438754
	PP	627614
<b>Adapter with 4 screws (DN 06...DN 65)</b>		
	Stainless steel	555484
	PVC	561175
	PP	561176
	PVDF	561177
<b>O-Ring set (DN 06...DN 65)</b>		
Between T-fitting body & adapter: flat seal to use for holder with groove (old variant, no more available for order), O-Ring to use for holder with lug (variant "v2")		
	FKM - for metal fitting (5 units)	428971
	EPDM - for metal fitting (5 units)	428972
	FKM - for plastic fitting (1 flat seal + 1 O-ring)	561043
	EPDM - for plastic fitting (1 flat seal + 1 O-ring)	561044

DTS 1000011768 EN Version: AR Status: RL (released | freigegeben | valide) printed: 27.05.2024

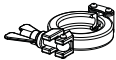
## Accessories for fitting for flowmeter Type 8041/8045 with clamp process connection

Accessory	Description	Article no.
	1 EPDM fitting/measuring device seal	730837 
	1 FEP fitting/measuring device seal	730839 
	Clamp collar	731164 
	Stopper for fitting	565200 