







Pneumatically operated 2/2-way globe valve CLASSIC

- Compact
- Long service life
- Robust actuators with modular accessory program
- Stainless steel housing with flange, thread and weld end connection

Product variants described in the data sheet may differ from the product presentation and description.

Can be combined with

	Type 8640 ▶ Modular valve island for pneumatics
	Type 8644 ▶ AirLINE SP electropneumatic automation system
	Type 8697 ▶ Pneumatic control unit for decentralised automation of process valves ELEMENT
	Type 6014 ▶ Plunger valve 3/2-way direct-acting
	Type 8840 ▶ Modular process valve cluster - distributor and collector

Type description

The externally piloted globe valve consists of a pneumatically operated piston actuator and a 2/2-way valve body. The actuator is made of PA or, for special operating conditions, PPS. The reliable self-adjusting packing gland provides high sealing integrity. These maintenance-free and robust valves can be retro-fitted with a comprehensive range of accessories for position indication, stroke limitation or manual override.

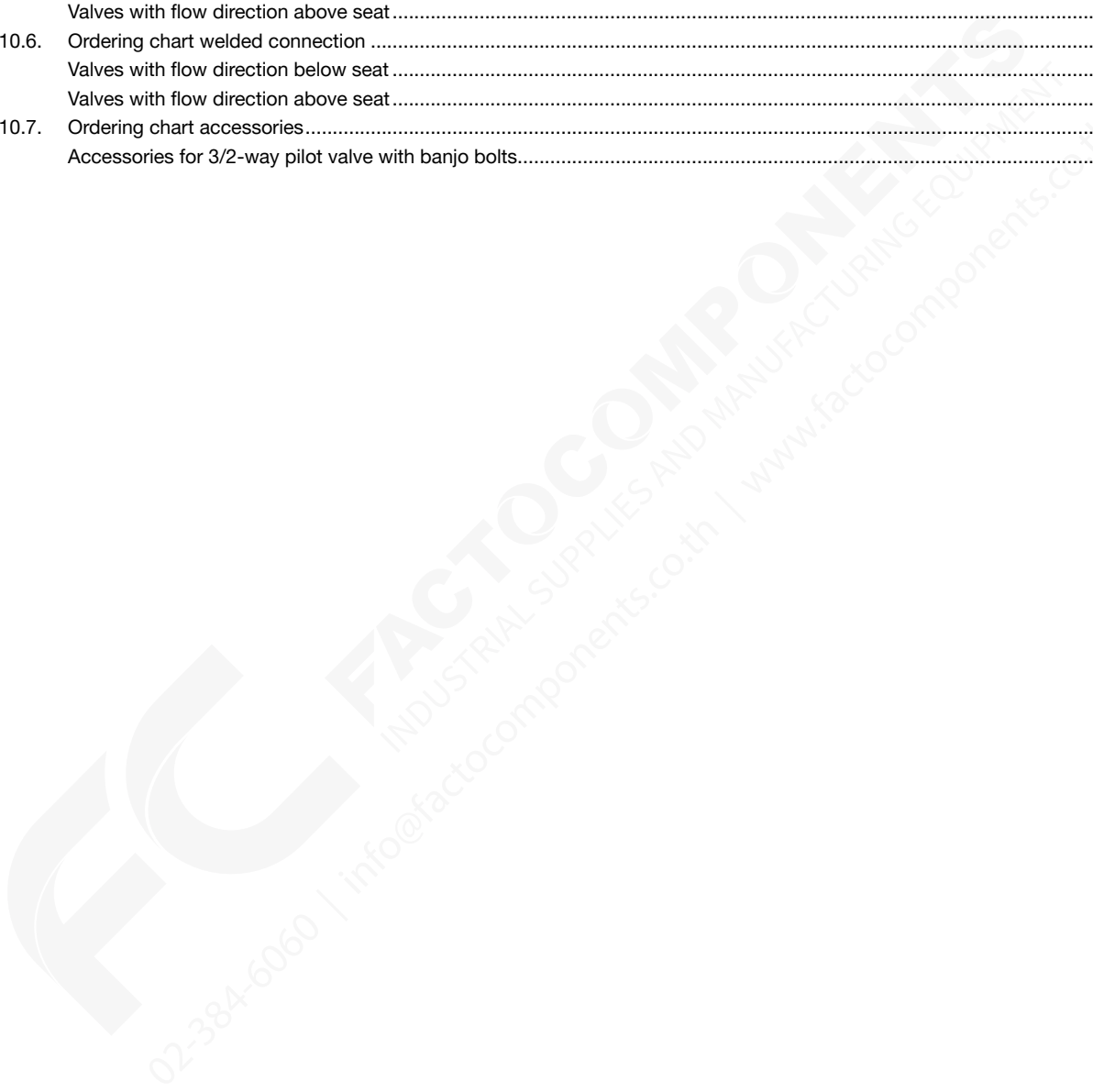

Table of contents

1. General technical data	4
2. Product versions	5
2.1. Stainless steel body with PA actuator.....	5
2.2. Stainless steel body with PPS actuator.....	5
3. Control functions	6
4. Approvals and conformities	7
4.1. General notes.....	7
4.2. Conformity.....	7
4.3. Standards.....	7
4.4. Explosion protection.....	7
4.5. Drinking water.....	7
4.6. Foods and beverages/Hygiene.....	8
4.7. Others.....	8
Oxygen.....	8
Fuel gases.....	8
5. Materials	8
5.1. Bürkert resistApp.....	8
5.2. Material specifications.....	9
6. Dimensions	10
6.1. Actuator.....	10
Globe valve Type 2012 and valve system On/Off CLASSIC Type 8801-GA.....	10
6.2. Body with flange connection.....	11
6.3. Body with threaded connection.....	12
6.4. Body with welded connection.....	13
7. Performance specifications	14
7.1. Fluidic data.....	14
Overview of fluidic data for flow below seat (for liquids, steam and gases).....	14
Pilot pressure diagram with flow direction below seat (control function B).....	15
Overview of fluidic data with flow above seat (for gases and steam).....	16
Pilot pressure diagram for flow direction above seat (control function A).....	17
7.2. Operating limits.....	18
Operating limits for medium temperature and operating pressure.....	18
Operating limits for ambient and medium temperature.....	19
Operating limits for optional versions.....	19
8. Product accessories	20
9. Networking and combination with other Bürkert products	21

10. Ordering information	22
10.1. Bürkert eShop	22
10.2. Bürkert product filter	22
10.3. Bürkert Product Enquiry Form	22
10.4. Ordering chart flange connection	23
Valves with flow direction below seat	23
Valves with flow direction above seat	24
10.5. Ordering chart thread connection	25
Valves with flow direction below seat	25
Valves with flow direction above seat	26
10.6. Ordering chart welded connection	27
Valves with flow direction below seat	27
Valves with flow direction above seat	29
10.7. Ordering chart accessories	30
Accessories for 3/2-way pilot valve with banjo bolts	30

DTS 1000010970 EN Version: AH Status: RL (released | freigegeben | validé) printed: 20.03.2024



1. General technical data

Product properties	
Dimensions	Further information can be found in chapter “6. Dimensions” on page 10.
Material	Further information can be found in chapter “5. Materials” on page 8.
Design	Globe valve
Nominal diameter (port connection)	DN 10...DN 100, NPS ½...NPS 4
Safety setting in case of power failure	Normally closed (control function A), normally open (control function B)
Flow direction	Flow to open (below seat), flow to close (above seat)
Performance data	
Operating pressure	0...25 bar(g), vacuum variant up to -0.9 bar(g) (option)
Nominal pressure	PN 25 (DIN EN 1333), Class 150 (DIN EN 1759)
Pilot pressure	2...10 bar(g) (see “7.1. Fluidic data” on page 14)
Seat leakage	Leakage rate A (according to DIN EN 12266 - 1), seat seal PTFE and PEEK, test medium air
K _v value	4.7...165 m ³ /h (see “7.1. Fluidic data” on page 14)
Medium data	
Medium	Steam, water, neutral gases, alcohols, oils, fuels, hydraulic fluids, salt solutions, alkalis, organic solvents, oxygen and fuel gases of families I, II and III in accordance with the Gas Appliances Regulation (EU) 2016/426
Medium temperature	-40...+230 °C (see “7.2. Operating limits” on page 18)
Viscosity	Max. 600 mm ² /s
Control medium	Air, neutral gases
Process/Port connection & communication	
Port connection	
Flange connection	DIN EN 1092 - 1 ANSI B 16.5 JIS 10K
Threaded connection	G (DIN ISO 228 - 1) NPT (ASME B1.20.1) RC (ISO 7 - 1)
Welded connection	DIN EN ISO 1127 / ISO 4200 / DIN 11866 series B DIN 11850 - 2 / DIN 11866 series A ASME BPE / DIN 11866 series C SMS 3008
Clamp connection	DIN 32676 series B (pipe: ISO 4200) DIN 32676 series A (pipe: DIN 11850 - 2) ASME BPE
Pilot air port	
Actuator size Ø 40 (C)	Thread G ⅛
Actuator size Ø 50 (D) ... 225 (L)	Thread G ¼
Approvals and conformities	
Further information can be found in chapter “4. Approvals and conformities” on page 7.	
Material certificate	2.2, 3.1
Environment and installation	
Ambient temperature	-10...+140 °C (see “2. Product versions” on page 5)
Degree of protection	IP67
Installation position	As required, preferably with actuator in upright position

2. Product versions

2.1. Stainless steel body with PA actuator



Performance data

Maximum pilot pressure

Actuator size 40 (C), 50 (D), 63 (E), 80 (F)	10 bar(g)
Actuator size 100 (G), 125 (H)	7 bar(g)
Actuator size 175 (K), 225 (L)	6 bar(g)

Medium data

Medium temperature	-10 °C...+185 °C (see "7.2. Operating limits" on page 18)
--------------------	---

Environment and installation

Ambient temperature

Actuator size 40 (C)...125 (H)	-10 °C...+60 °C
Actuator size 175 (K), 225 (L)	-10 °C...+50 °C

2.2. Stainless steel body with PPS actuator



Performance data

Maximum pilot pressure

Actuator size 40 (C), 50 (D), 63 (E), 80 (F)	10 bar(g)
Actuator size 100 (G), 125 (H)	7 bar(g)

Medium data

Medium temperature	-40 °C...+230 °C (see "7.2. Operating limits" on page 18)
--------------------	---

Environment and installation

Ambient temperature	+5 °C...+140 °C (continuous operation...+130 °C) (see "7.2. Operating limits" on page 18)
---------------------	--

3. Control functions

⚠ WARNING
Risk of damage due to bursting pipes and bursting equipment when the flow is above the seat.
In the case of liquid mediums, water hammer can occur causing pipes and the device to burst.
 Do not use valves with flow above the seat for liquid mediums.

Symbol	Description	
Flow direction below seat for liquids, steam and gases		
	Control function A (CF A) Pneumatically operated 2/2-way on/off valve Flow direction below seat Normally closed by spring force	
	Control function B (CF B) Pneumatically operated 2/2-way on/off valve Flow direction above seat Normally opened by spring force	
Flow direction above seat for steam and gases		
	Control function A (CF A) Pneumatically operated 2/2-way on/off valve Flow direction above seat Normally closed by spring force	

DTS 1000010970 EN Version: AH Status: RL (released | freigegeben | validé) printed: 20.03.2024

4. Approvals and conformities

4.1. General notes

- The approvals and conformities listed below must be stated when making enquiries. This is the only way to ensure that the product complies with all required specifications.
- Not all available versions can be supplied with the below mentioned approvals or conformities.

4.2. Conformity



In accordance with the Declaration of Conformity, the product is compliant with the EU Directives. This includes the following directives:

- Pressure Equipment Directive 2014/68/EU
- Machinery Directive 2006/42/EG

4.3. Standards

The applied standards which are used to demonstrate compliance with the EU Directives are listed in the EU-Type Examination Certificate and/or the EU Declaration of Conformity.

4.4. Explosion protection

Approval	Description																								
 	<p>Optional: Explosion protection As a category 2 device suitable for zone 1/21 and zone 2/22 (optional).</p> <p>ATEX: EPS 18 ATEX 2 008 X II 2G Ex h IIC T4...T2 Gb II 2D Ex h IIIC T135 °C...T300 °C Db</p> <p>IECEX: IECEX EPS 18.0007 X Ex h IIC T4...T2 Gb Ex h IIIC T135 °C...T300 °C Db</p> <table border="1"> <thead> <tr> <th>Temperature class</th> <th>T2</th> <th>T3</th> <th>T4</th> </tr> </thead> <tbody> <tr> <td>Permissible surface temperature</td> <td>+300 °C</td> <td>+200 °C</td> <td>+135 °C</td> </tr> <tr> <td>Ambient temperature</td> <td>-40...+80 °C</td> <td>-40...+80 °C</td> <td>-40...+80 °C</td> </tr> <tr> <td>Restrictions from the device</td> <td></td> <td></td> <td></td> </tr> <tr> <td>Maximum medium temperature</td> <td>+230 °C</td> <td>+185 °C</td> <td>+125 °C</td> </tr> <tr> <td>Restrictions from the device</td> <td></td> <td></td> <td></td> </tr> </tbody> </table>	Temperature class	T2	T3	T4	Permissible surface temperature	+300 °C	+200 °C	+135 °C	Ambient temperature	-40...+80 °C	-40...+80 °C	-40...+80 °C	Restrictions from the device				Maximum medium temperature	+230 °C	+185 °C	+125 °C	Restrictions from the device			
Temperature class	T2	T3	T4																						
Permissible surface temperature	+300 °C	+200 °C	+135 °C																						
Ambient temperature	-40...+80 °C	-40...+80 °C	-40...+80 °C																						
Restrictions from the device																									
Maximum medium temperature	+230 °C	+185 °C	+125 °C																						
Restrictions from the device																									

4.5. Drinking water

Conformity	Description
	<p>Suitable for use in drinking water applications The materials comply with the assessment principles (UBA) for materials in contact with drinking water (TrinkwasserV).</p> <p>Stainless steel body PF39: Suitable for products with medium temperature up to 85 °C (hot water)</p>

DTS 1000010970 EN Version: AH Status: RL (released | freigegeben | validé) printed: 20.03.2024

4.6. Foods and beverages/Hygiene

Conformity	Description
FDA	FDA – Code of Federal Regulations (valid for the variable code PL02) All wetted materials are compliant with the Code of Federal Regulations published by the FDA (Food and Drug Administration, USA) according to the manufacturer’s declaration.
	EC Regulation 1935/2004 of the European Parliament and of the Council (valid for the variable code PL01, PL02) All wetted materials are compliant with EC Regulation 1935/2004/EC according to the manufacturer’s declaration.

4.7. Others

Oxygen

Conformity	Description
O ₂	Optional: Suitability for oxygen (valid for the variable code NL02) The products are suitable for use with gaseous oxygen, according to the manufacturer’s declaration.

Fuel gases

Conformity	Description
	Fuel gases (valid for the variable code PO19, PO20) The products comply with: <ul style="list-style-type: none"> • Regulation (EU) 2016/426 – Appliances burning gaseous fuels and • DVGW DIN EN 161 (Automatic shut-off valves for gas burners and gas appliances) and • DIN EN 16678, Class A or Class D (Safety and control devices for gas burners and gas burning appliances – Automatic shut-off valves for operating pressure of above 500 kPa up to and including 6 300 kPa)

5. Materials

5.1. Bürkert resistApp

Bürkert resistApp – Chemical resistance chart

You want to ensure the reliability and durability of the materials in your individual application case? Verify your combination of media and materials on our website or in our resistApp.

[Start chemical resistance check](#)

DTS 1000010970 EN Version: AH Status: RL (released | freigegeben | validé) printed: 20.03.2024

5.2. Material specifications

Actuator size 40...125 mm

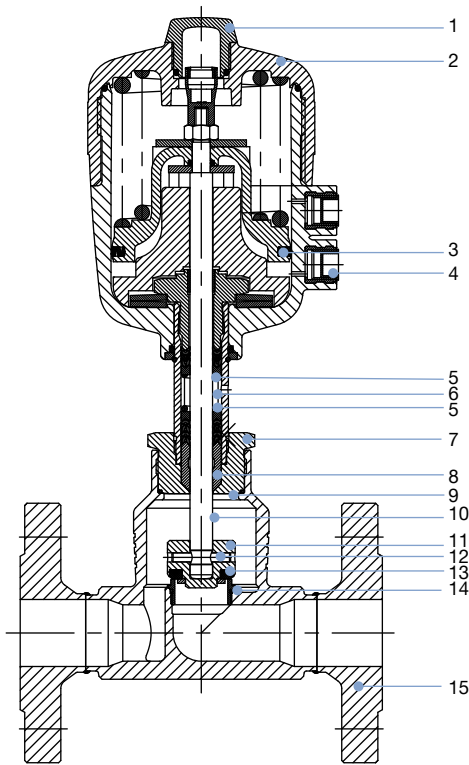

No.	Element	Material	
		Stainless steel body with PA actuator	Stainless steel body with PPS actuator
1	Transparent cover	PC	PSU
2	Actuator	PA	PPS
3	Piston seal	NBR	FKM
4	Pilot air ports	Stainless steel 1.4305	
5	Spindle seal	PTFE V-Rings (filled), with spring compensation	
6	Spring	Stainless steel 1.4310	
7	Pipe	Stainless steel 1.4401 or 316L	
8	Wiper	PTFE (filled), PEEK for actuator size 100 mm(G) and 125 mm(H)	
9	Body seal	Graphite, PTFE (option)	
10	Spindle	Stainless steel 1.4401 or 1.4404	
11	Swivel plate	Stainless steel 1.4401 or 1.4404	
12	Pin	Stainless steel 1.4401	
13	Seat seal	PTFE, PEEK (option), NBR (option), FKM (option)	
14	Valve seat with O-Ring	Stainless steel 1.4571, EPDM	
15	Valve body	Stainless steel CF3M	

Actuator size 175 and 225 mm

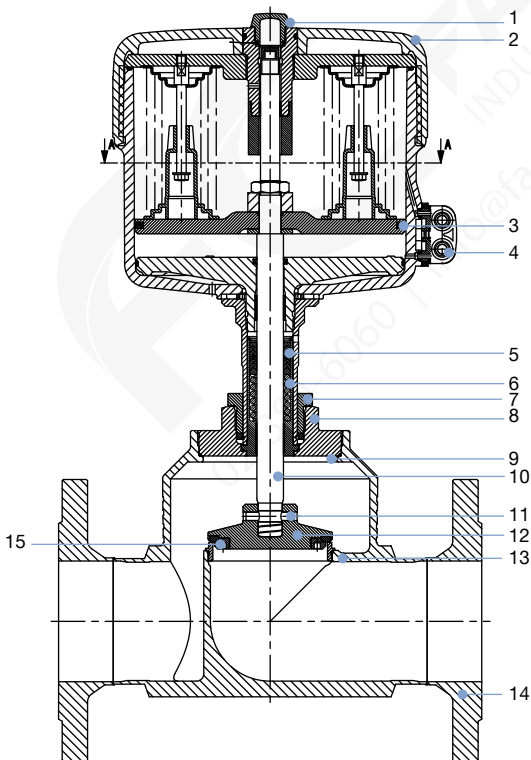

No.	Element	Material	
		Stainless steel body with PA actuator	Stainless steel body with PPS actuator
1	Transparent cover	PC	
2	Actuator	PA	
3	Piston seal	NBR	
4	Pilot air ports	Stainless steel 1.4305	
5	Spindle seal	PTFE V-Rings (filled), with spring compensation	
6	Spring	Stainless steel 1.4568	
7	Screw	Stainless steel 1.4305	
8	Nipple	Stainless steel 1.4404	
9	Body seal	Graphite, PTFE (option)	
10	Spindle	Stainless steel 1.4401	
11	Pin	Stainless steel 1.4401	
12	Swivel plate	Stainless steel 1.4401	
13	Seat seal	PTFE, PEEK (option), NBR (option), FKM (option)	
14	Valve seat with O-ring	Stainless steel 1.4571, EPDM	
15	Valve body	Stainless steel CF3M	

DTS 1000010970 EN Version: AH Status: RL (released | freigegeben | valide) printed: 20.03.2024

6. Dimensions

6.1. Actuator

Globe valve Type 2012 and valve system On/Off CLASSIC Type 8801-GA

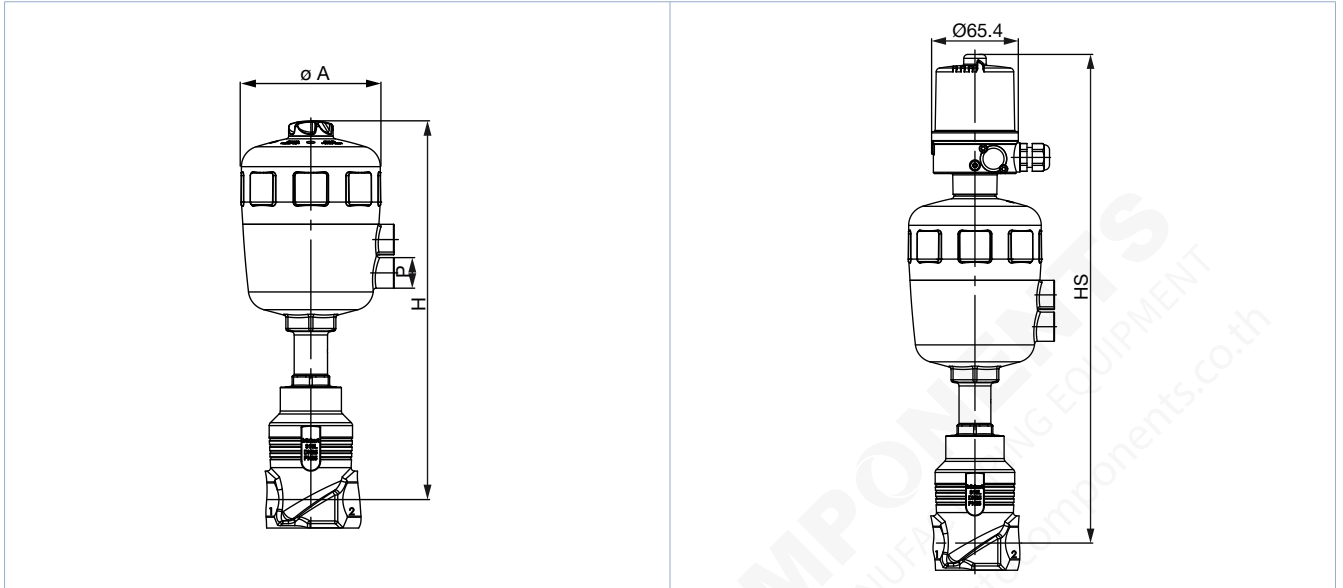

Nominal diameter (port connection)		Actuator size Ø	Ø A	H	P	HS
DN	NPS	[mm]	[mm]	[mm]	[inch]	[mm]
10	3/8	40 (C)	53	185	G 1/8	281
		50 (D)	64	211	G 1/4	307
		63 (E)	80	253	G 1/4	349
15	1/2	40 (C)	53	185	G 1/8	281
		50 (D)	64	211	G 1/4	307
		63 (E)	80	253	G 1/4	349
20	3/4	40 (C)	53	187	G 1/8	283
		50 (D)	64	214	G 1/4	310
		63 (E)	80	248	G 1/4	344
		80 (F)	101	270	G 1/4	366
25	1	50 (D)	64	220	G 1/4	316
		63 (E)	80	251	G 1/4	347
		80 (F)	101	273	G 1/4	369
32	1 1/4	63 (E)	80	272	G 1/4	368
		80 (F)	101	294	G 1/4	390
		125 (H)	157	390	G 1/4	483
40	1 1/2	80 (F)	101	299	G 1/4	395
		125 (H)	157	395	G 1/4	488
50	2	80 (F)	101	309	G 1/4	405
		100 (G)	127	371	G 1/4	464
		125 (H)	157	400	G 1/4	493
65	2 1/2	125 (H)	157	429	G 1/4	522
		175 (K)	211	491	G 1/4	590
		225 (L)	261	486	G 1/4	585
80	3	125 (H)	157	438	G 1/4	531
		175 (K)	211	498	G 1/4	597
		225 (L)	261	494	G 1/4	593
100	4	125 (H)	157	449	G 1/4	542
		175 (K)	211	508	G 1/4	607
		225 (L)	261	504	G 1/4	603

DTS 1000010970 EN Version: AH Status: RL (released | freigegeben | validé) printed: 20.03.2024

6.2. Body with flange connection

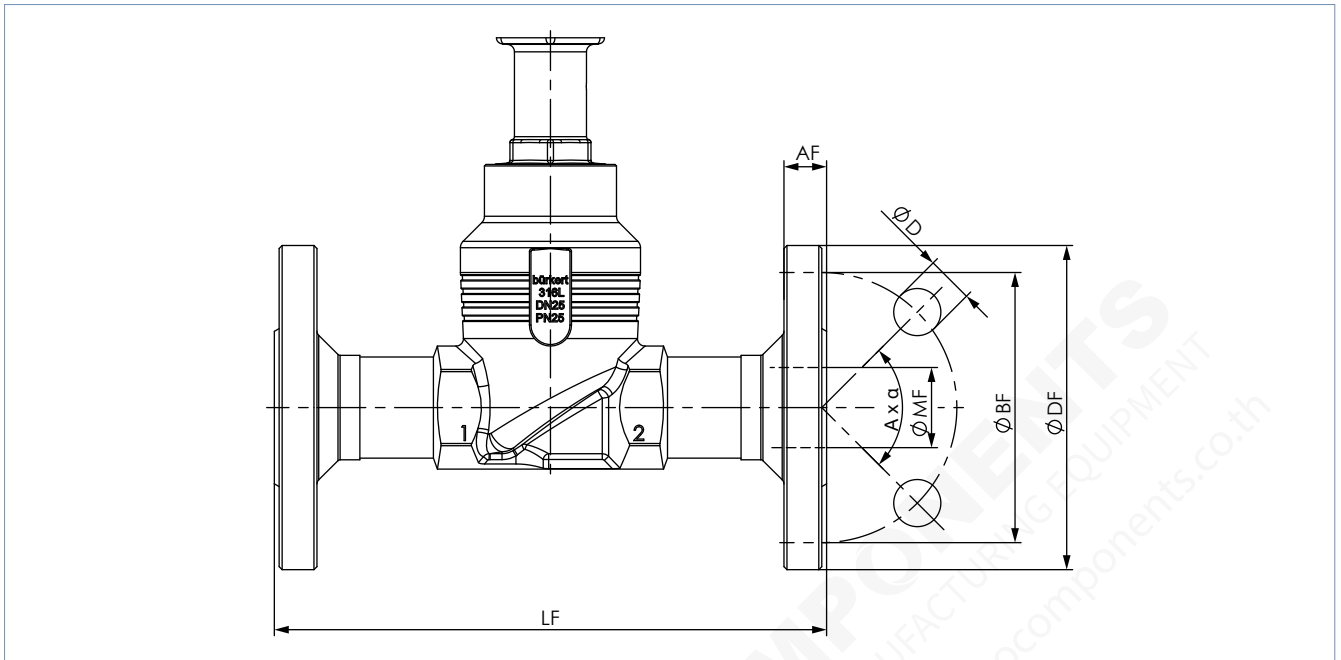

Nominal diameter (port connection)	DIN EN 1092 PN 25 FTF 1 according to DIN EN 558 - 1							JIS 10K FTF 10 according to DIN EN 558 - 2						
	Ø DF	LF	Ø BF	AF	Ø D	A x α	Ø MF	Ø DF	LF	Ø BF	AF	Ø D	A x α	Ø MF
10	90	130	60	16	14	4 x 90°	13.6	-	-	-	-	-	-	-
15	95	130	65	16	14	4 x 90°	18.1	95	108	70	12	15	4 x 90°	18.1
20	105	150	75	18	14	4 x 90°	23.7	100	117	75	14	15	4 x 90°	23.7
25	115	160	85	18	14	4 x 90°	29.7	125	127	90	14	19	4 x 90°	29.7
32	140	180	100	18	18	4 x 90°	38.4	135	140	100	16	19	4 x 90°	38.4
40	150	200	110	18	18	4 x 90°	44.3	140	165	105	16	19	4 x 90°	44.3
50	165	230	125	20	18	4 x 90°	56.3	155	203	120	16	19	4 x 90°	56.3
65	185	290	145	22	18	8 x 45°	66.0	175	216	140	18	19	4 x 90°	71.5
80	200	310	160	24	18	8 x 45°	81.0	185	241	150	18	19	8 x 45°	84.3
100	235	350	190	24	22	8 x 45°	100.0	292	292	175	18	19	8 x 45°	109.1

Nominal diameter (port connection)	ANSI B 16.5 Class 150 FTF 37 according to DIN EN 558 - 2						
	Ø DF	LF	Ø BF	AF	Ø D	A x α	Ø MF
½	89	184	60.5	11.2	15.7	4 x 90°	15.7
¾	99	184	69.9	12.7	15.7	4 x 90°	20.8
1	108	184	79.2	14.2	15.7	4 x 90°	26.7
1½	127	222	98.6	17.5	15.7	4 x 90°	40.9
2	152	254	120.7	19.1	19.1	4 x 90°	52.6
2½	178	276	139.7	22.3	19.1	4 x 90°	62.7
3	190	298	152.5	23.9	19.1	4 x 90°	78.0
4	229	352	190.5	23.9	19.1	8 x 45°	102.4

DTS 1000010970 EN Version: AH Status: RL (released | freigegeben | validé) printed: 20.03.2024

6.3. Body with threaded connection

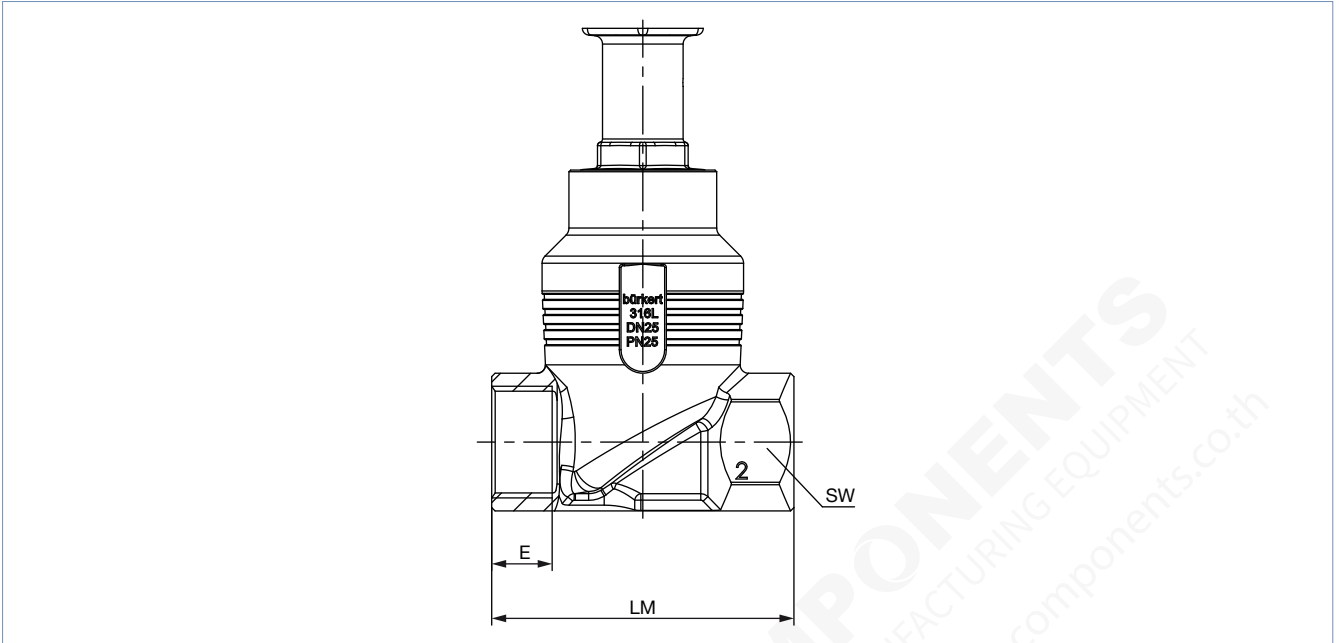

Nominal diameter (port connection)		G (DIN ISO 228 - 1) NPT (ASME B1.20.1) RC (ISO 7 - 1)			LM	SW
DN	NPS	G	NPT	RC		
10	3/8	12	10.3	10.1	65	27
15	1/2	14	13.7	13.2	65	27
20	3/4	16	14	14.5	75	34
25	1	18	16.8	16.8	90	41
32	1 1/4	20	17.3	19.1	110	50
40	1 1/2	22	17.3	19.1	120	55
50	2	24	17.6	23.4	150	70
65	2 1/2	26	23.7	26.7	185	85
80	3	28	30.5	29.8	205	100
100	4	32	33	35.8	240	125

DTS 1000010970 EN Version: AH Status: RL (released | freigegeben | validé) printed: 20.03.2024

6.4. Body with welded connection

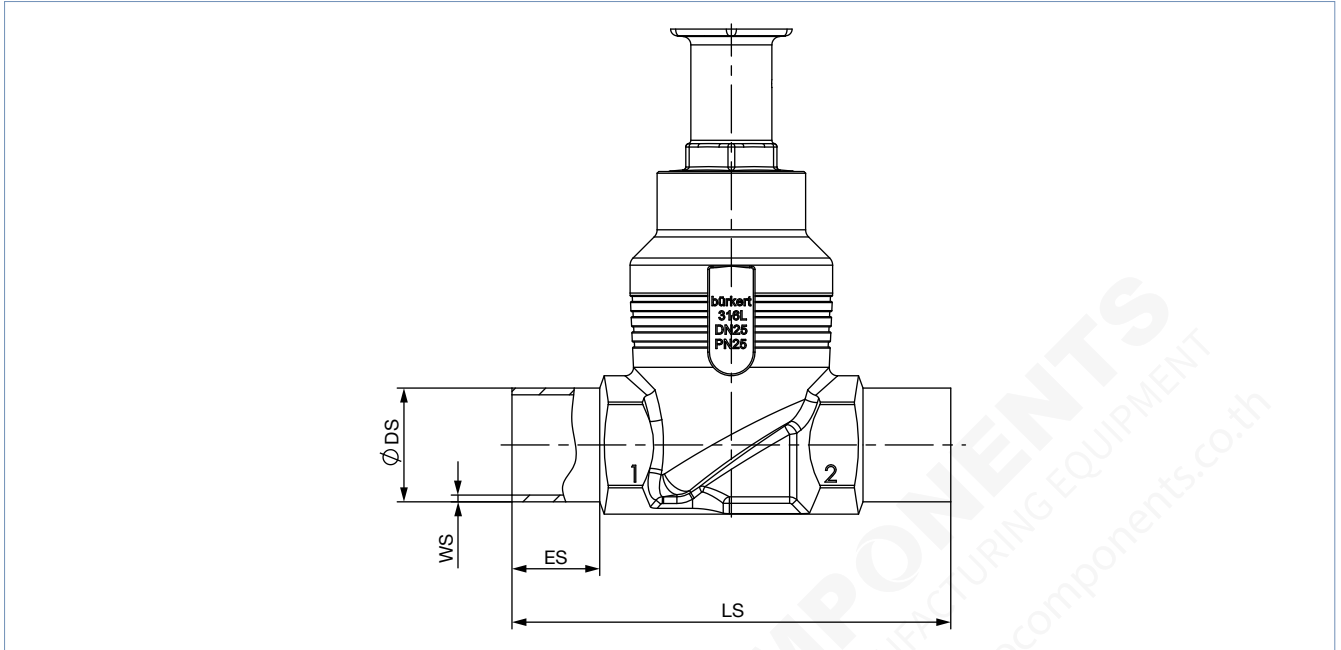

Nominal diameter (port connection) DN	ES	LS	DIN EN ISO 1127 / ISO 4200 / DIN 11866 series B		DIN 11850-2 / DIN 11866 series A / DIN EN 10357 series A	
			Ø DS	WS	Ø DS	WS
10	20	90	17.2	1.6	13	1.5
15	20	90	21.3	1.6	19	1.5
20	20	100	26.9	1.6	23	1.5
25	26	130	33.7	2.0	29	1.5
32	26	140	42.4	2.0	35	1.5
40	26	150	48.3	2.0	41	1.5
50	26	175	60.3	2.0	53	1.5
65	26	210	76.1	2.3	70	2.0
80	26	230	88.9	2.3	85	2.0
100	26	260	114.3	2.6	104	2.0

Nominal diameter (port connection) NPS	ES	LS	ASME BPE/DIN 11866 series C	
			Ø DS	WS
½	20	90	12.7	1.65
¾	20	90	19.05	1.65
1	20	100	25.4	1.65
1½	26	140	38.1	1.65
2	26	150	50.8	1.65
2½	26	175	63.5	1.65
3	26	210	76.2	1.65
4	26	260	101.6	2.11

DTS 1000010970 EN Version: AH Status: RL (released | freigegeben | validé) printed: 20.03.2024

7. Performance specifications

7.1. Fluidic data

Overview of fluidic data for flow below seat (for liquids, steam and gases)

Note:

- K_v value [m^3/h]: Measured with water at +20 °C, 1 bar(g) pressure at valve inlet and free outlet
- Pressure data [bar(g)]: Overpressure to atmospheric pressure

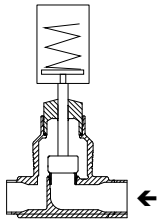

Nominal diameter (port connection)		Actuator size Ø	K_v value water	Pilot pressure min. CF A	Operating pressure max.		
DN	NPS				PTFE	PEEK	CF B
		[mm]	[m^3/h]	[bar(g)]	[bar(g)]	[bar(g)]	[bar(g)]
10	3/8	40 (C)	4.7	4	15	–	16
		50 (D)	4.7	4.1	16	16	16
		63 (E)	4.7	4.5	25	25	25
15	1/2	40 (C)	4.7	4	15	–	16
		50 (D)	4.7	4.1	16	16	16
		63 (E)	4.7	4.5	25	25	25
20	3/4	40 (C)	8.1	4	6.5	–	16
		50 (D)	8.1	4.1	11	9	16
		63 (E)	8.1	4.5	20	17.5	25
		80 (F)	8.1	5	25	25	–
25	1	63 (E)	13	4.5	11	10	25
		80 (F)	13	5	25	23	25
32	1 1/4	63 (E)	20	4.5	6	–	25
		80 (F)	20	5	14	12.5	25
		125 (H)	20	3.2	25	22.5	–
40	1 1/2	80 (F)	31	5	9	–	25
		125 (H)	31	4.2	25	–	–
50	2	100 (G)	45	4.4	7.2	–	25 (20 ^{1.)})
		125 (H)	45	5.7	24 (20 ^{1.)})	20	–
65	2 1/2	125 (H)	73	5.7	12	10	23 (15 ^{1.)})
		175 (K)	73	4.5	16 (15 ^{1.)})	–	16 (15 ^{1.)})
		225 (L)	73	4.8	25 (15 ^{1.)})	–	–
80	3	125 (H)	110	5.7	7.5	6.5	14 (12.5 ^{1.)})
		175 (K)	110	4.5	10	–	16 (12.5 ^{1.)})
		225 (L)	110	4.8	25 (12.5 ^{1.)})	–	–
100	4	125 (H)	165	5.7	5	4	9
		175 (K)	155	4.5	7	–	14 (10 ^{1.)})
		225 (L)	155	4.8	16 (10 ^{1.)})	–	–

1.) According to pressure equipment directive 2014/68/EU for compressible fluids of group 1 (dangerous gases and vapours according to article 4, paragraph (1), c), i), first indent)

Pilot pressure diagram with flow direction below seat (control function B)

Actuator size Ø 40 mm (C)

Maximum control pressure 10 bar(g)

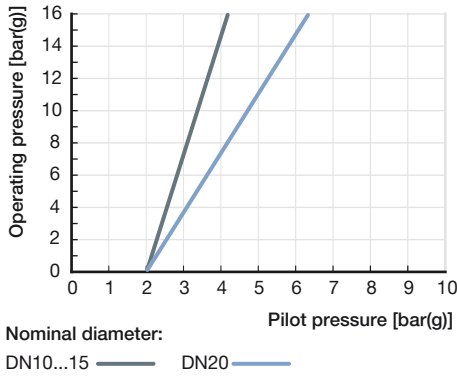

Actuator size Ø 50 mm (D)

Maximum control pressure 10 bar(g)

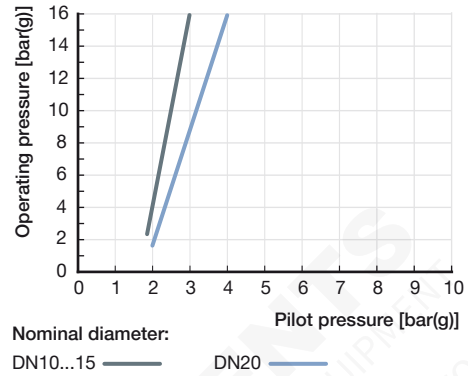

Actuator size Ø 63 mm (E)

Maximum control pressure 10 bar(g)

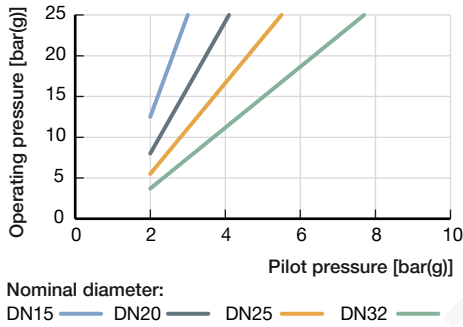

Actuator size Ø 80 mm (F)

Maximum control pressure 10 bar(g)

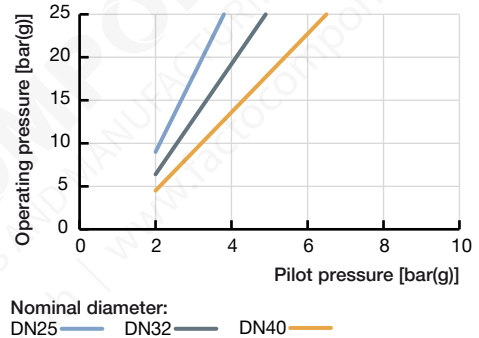

Actuator size Ø 100 mm (G)

Maximum control pressure 7 bar(g)

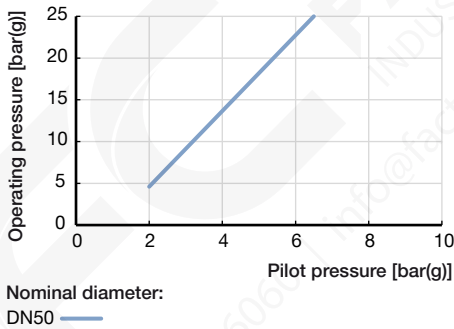

Actuator size Ø 125 mm (H)

Maximum control pressure 7 bar(g)

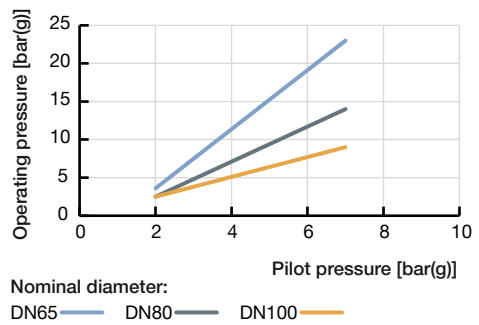

Actuator size Ø 175 mm (K)

Maximum control pressure 6 bar(g)

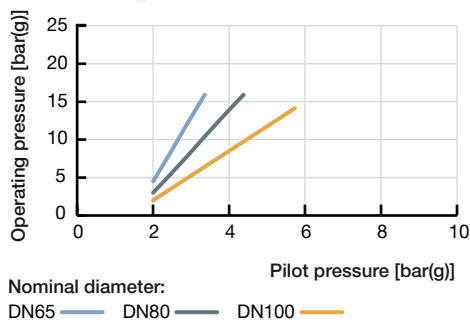

DTS 1000010970 EN Version: AH Status: RL (released | freigegeben | validé) printed: 20.03.2024

Overview of fluidic data with flow above seat (for gases and steam)

Note:

- K_v value [m³/h]: Measured with water at +20 °C, 1 bar(g) pressure at valve inlet and free outlet
- Pressure data [bar(g)]: Overpressure to atmospheric pressure
- Valves with flow direction above the seat are only partially suitable for liquid mediums. There is a risk of a pressure surge.

⚠ WARNING
Risk of damage due to bursting pipes and bursting equipment when the flow is above the seat.
In the case of liquid mediums, water hammer can occur, causing pipes and the device to burst.
 Do not use valves with flow above the seat for liquid mediums.

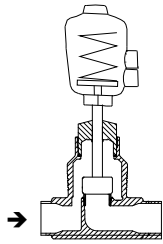

Nominal diameter (port connection)		Actuator size Ø	K_v value water	Operating pressure max.
DN	NPS	[mm]	[m ³ /h]	CF A PTFE [bar(g)]
10	3/8	40 (C)	3	16
		50 (D)	3	16
15	1/2	40 (C)	4.7	16
		50 (D)	4.7	16
20	3/4	40 (C)	8.1	16
		50 (D)	8.1	16
25	1	50 (D)	13	16
32	1 1/4	63 (E)	20	16
40	1 1/2	80 (F)	31	16
50	2	80 (F)	45	16
65	2 1/2	125 (H)	73	10
80	3	125 (H)	110	10
100	4	125 (H)	165	6

DTS 1000010970 EN Version: AH Status: RL (released | freigegeben | validé) printed: 20.03.2024

Pilot pressure diagram for flow direction above seat (control function A)

Actuator size Ø 40 mm (C)

Maximum control pressure 10 bar(g)

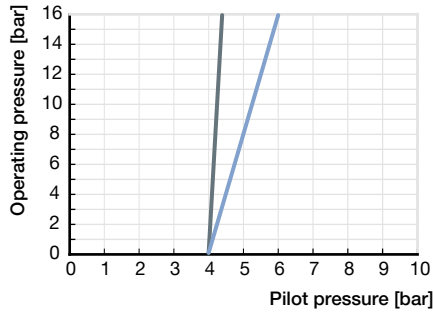

Nominal diameter:
 DN10...15 —
 DN20 —

Actuator size Ø 50 mm (D)

Maximum control pressure 10 bar(g)

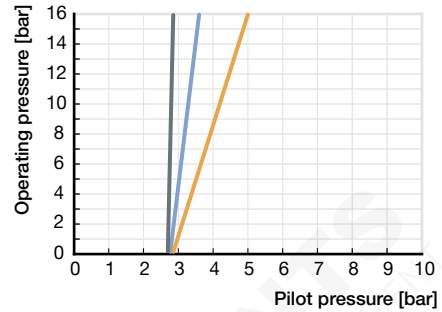

Nominal diameter:
 DN10...15 —
 DN20 —
 DN25 —

Actuator size Ø 63 mm (E)

Maximum control pressure 10 bar(g)

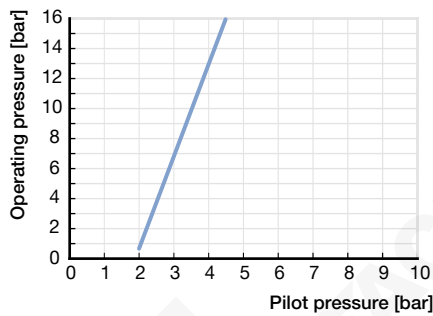

Nominal diameter:
 DN32 —

Actuator size Ø 80 mm (F)

Maximum control pressure 10 bar(g)

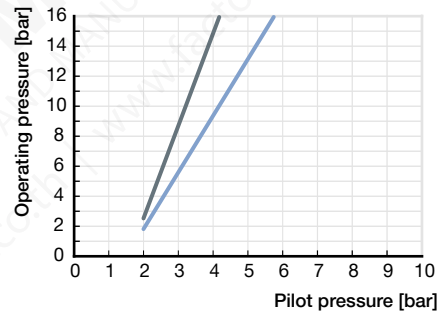

Nominal diameter:
 DN40 —
 DN50 —

Actuator size Ø 125 mm (H)

Maximum control pressure 7 bar(g)

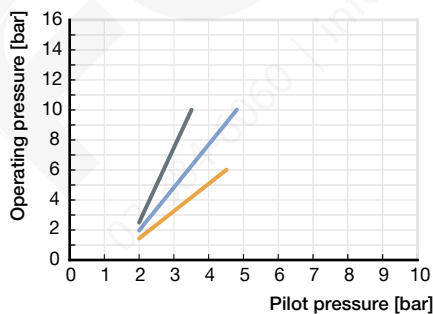

Nominal diameter:
 DN65 —
 DN80 —
 DN100 —

DTS 1000010970 EN Version: AH Status: RL (released | freigegeben | validé) printed: 20.03.2024

7.2. Operating limits

Operating limits for medium temperature and operating pressure

The operating range of Bürkert process valves is in addition to the maximum operating pressures limited by the nominal pressure according to the relevant standard.

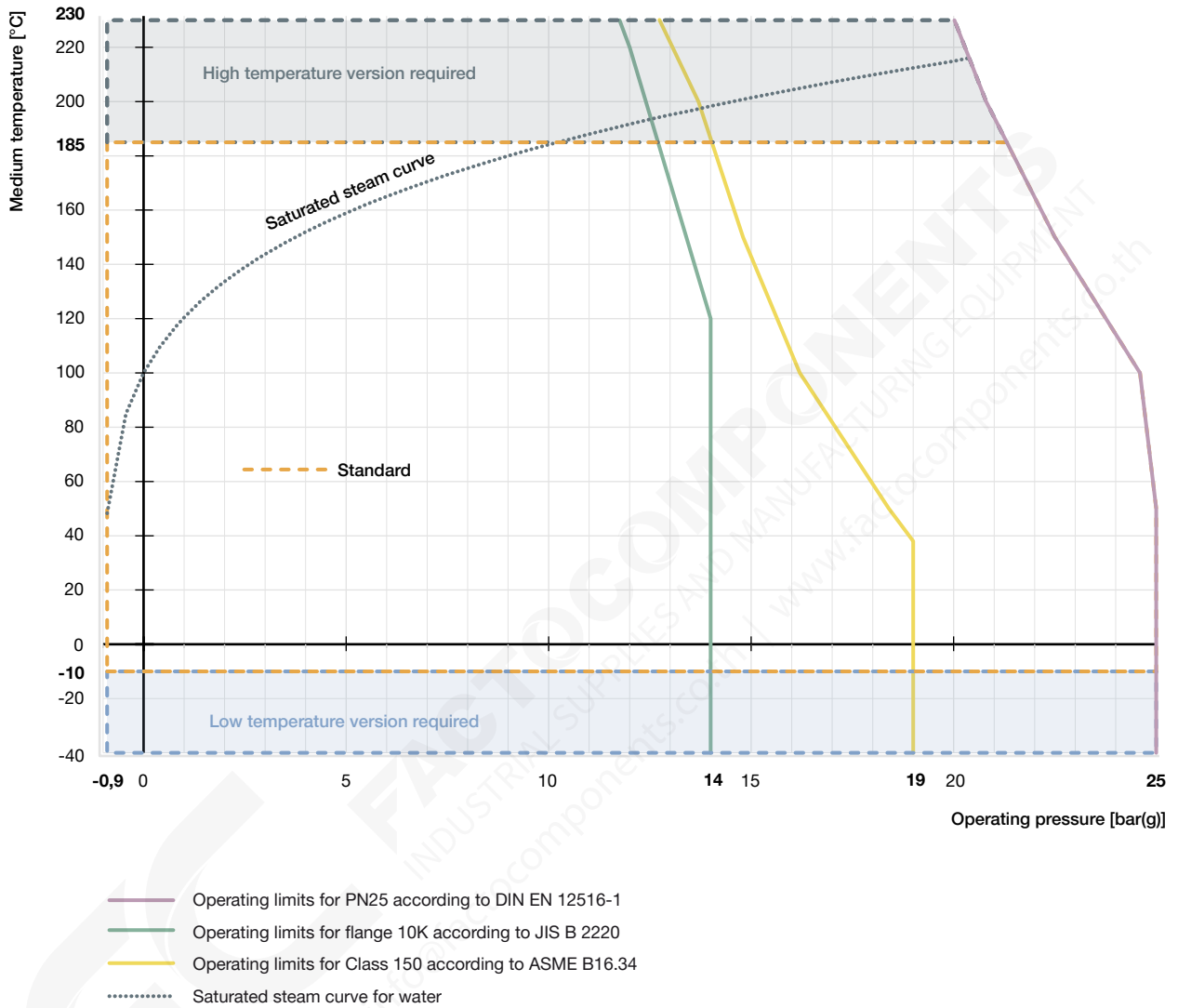

DTS 1000010970 EN Version: AH Status: RL (released | freigegeben | validé) printed: 20.03.2024

Operating limits for ambient and medium temperature

Note:

For size 40, 50 and 63 PA actuators, the combination of maximum medium temperature and maximum ambient temperature is shown in the following diagram:

Classic PA actuator

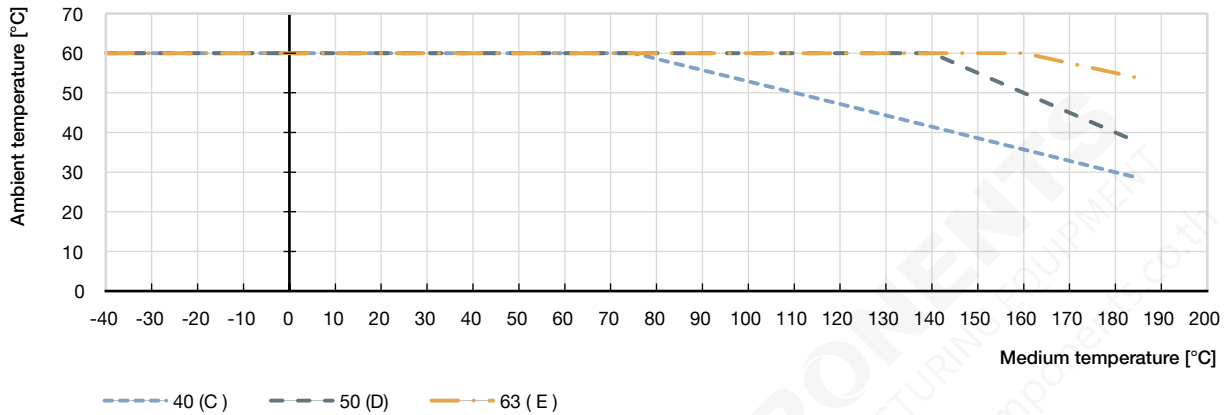

Classic PPS actuator

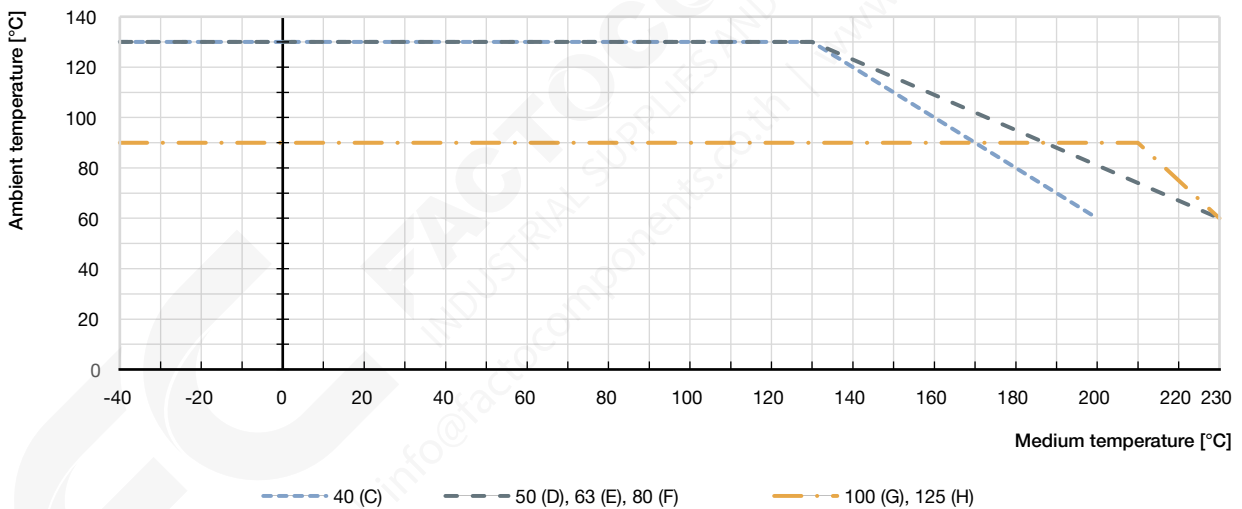

Operating limits for optional versions

High-temperature version

Thanks to an adaption of the spindle sealing and seat seal in PEEK, this version is suitable for applications with steam, neutral gases and other heat transfer mediums up to +230 °C.

Water version

For applications with water up to +200 °C, a special configuration of the spindle seal increases service life significantly. It is recommended for water temperatures starting at +85 °C.

Vacuum version

Without leakage bore, this design is suitable for pressures down to -0.9 bar(g).

Low-temperature version

Suitable for minimum medium temperatures down to -40 °C

DTS 1000010970 EN Version: AH Status: RL (released | freigegeben | validé) printed: 20.03.2024

8. Product accessories

Electric position feedback indicator	
Type 8697 ▶ Actuator size Ø 40 (C)...125 (H)	
	<p>The position feedback Type 8697 is designed for integrated mounting on CLASSIC series 20XX process valves, suiting the requirements of hygienic process environments. Mechanical or inductive limit switches register the position of the valve.</p> <p>Features</p> <ul style="list-style-type: none"> • Compact design • LED position indicator • Mechanical or inductive limit switches for end position registering • Easy-to-clean clean chemically resistant housing featuring IP65/IP67, 4X Rating • Optionally intrinsically safe variant according to IECEx <p>Customer benefits</p> <ul style="list-style-type: none"> • Easy and quick installation • High level of signal reliability thanks to self-adjusting limit switches • Minimised space requirement in the plant piping for more flexibility in plant design
Adaptation for proximity switch	
Type 2XXX ▶	
	<p>Various options for the use of inductive proximity switches are available for the CLASSIC series actuators:</p> <ul style="list-style-type: none"> • Nipple • Support bracket, 1-fold • Support bracket, 2-fold
Plunger valve 3/2-way direct acting	
Type 6012 ▶ for Actuator size Ø 40 (C)...63 (E), Type 6014 ▶ for Actuator size Ø 50 (D)...125 (H)	
	<p>For easy direct mounting to a pneumatic actuator, a banjo connection with banjo bolt is the ideal solution. An optional manual override allows fast commissioning and optimum maintenance.</p> <p>In conjunction with a cable plug according to DIN EN 175301 - 803 Form A or B, the valves meet protection class IP65.</p> <p>Features</p> <ul style="list-style-type: none"> • High reliability • Resistant according to IP65 <p>Customer benefits Easy and quick installation</p>
Stroke limiter	
Type 2XXX ▶	
	<p>Stroke limitations can be used to limit the minimum and maximum flow rate of the valves.</p> <p>Different variants are available:</p> <ul style="list-style-type: none"> • Maximum stroke limitation • Maximum and minimum stroke limitation with optical position indicator

DTS 1000010970 EN Version: AH Status: RL (released | freigegeben | validé) printed: 20.03.2024

9. Networking and combination with other Bürkert products

The globe valve Type 2012 can be combined with the feedback positioner Type 8697 to form the valve system On/Off CLASSIC Type 8801-GA.

Note:

- For the configuration of further valve systems use the **Product Enquiry Form** (see “10.3. Bürkert Product Enquiry Form” on page 22).
- You order two components and receive a completely assembled and tested valve.

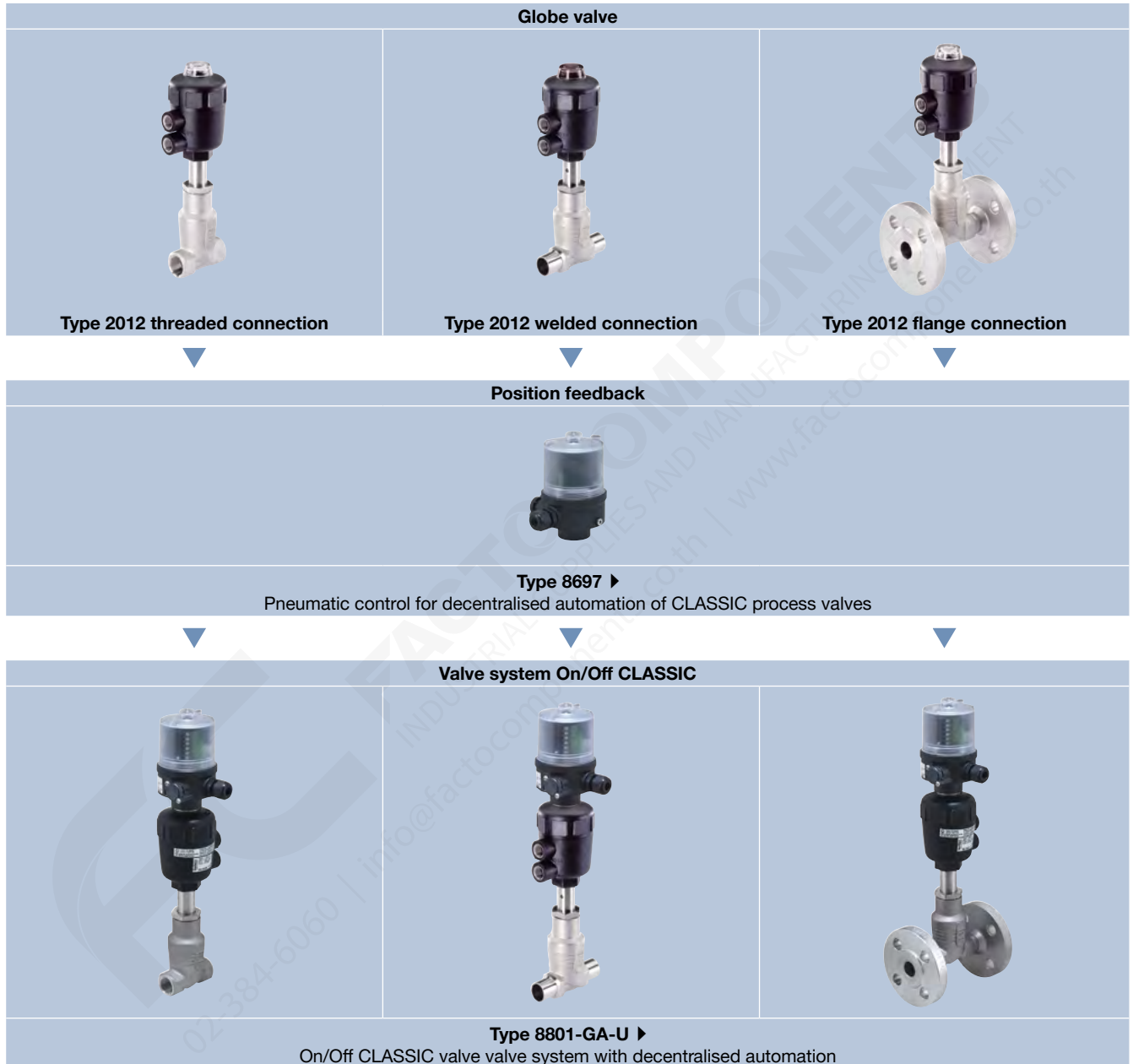

DTS 1000010970 EN Version: AH Status: RL (released | freigegeben | validé) printed: 20.03.2024

10. Ordering information

10.1. Bürkert eShop



Bürkert eShop – Easy ordering and quick delivery

You want to find your desired Bürkert product or spare part quickly and order directly? Our online shop is available for you 24/7. Sign up and enjoy all the benefits.

[Order online now](#)

10.2. Bürkert product filter



Bürkert product filter – Get quickly to the right product

You want to select products comfortably based on your technical requirements? Use the Bürkert product filter and find suitable articles for your application quickly and easily.

[Try out our product filter](#)

10.3. Bürkert Product Enquiry Form

Note:

Please see our Product Enquiry Form for a full explanation of our specification key.

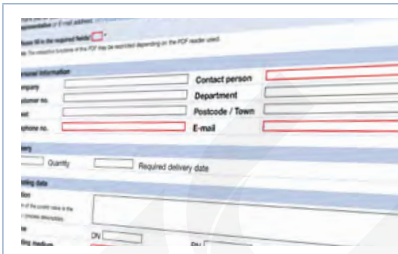

Bürkert Product Enquiry Form – Your enquiry quickly and compactly

Would you like to make a specific product enquiry based on your technical requirements? Use our Product Enquiry Form for this purpose. There you will find all the relevant information for your Bürkert contact. This will enable us to provide you with the best possible advice.

[Fill out the form now](#)

DTS 1000010970 EN Version: AH Status: RL (released | freigegeben | valide) printed: 20.03.2024

10.4. Ordering chart flange connection

Valves with flow direction below seat

Control function	Nominal diameter (port connection)	Actuator size Ø [mm]	K _v value water [m³/h]	Pilot pressure min. [bar(g)]	Operating pressure max. [bar(g)]	Article no.	
	DN					PA actuator	PPS actuator
DIN EN 1092 - 1						Stainless steel body	
A (CF A) see control functions ¹⁾	10	40 (C)	4.7	4.0	15	343814 ☒	344096 ☒
		50 (D)	4.7	4.1	16	343818 ☒	344095 ☒
	15	40 (C)	4.7	4.0	15	343823 ☒	o. r.
		50 (D)	4.7	4.1	16	343829 ☒	343912 ☒
	20	40 (C)	8.1	4.0	6.5	344116 ☒	o. r.
		50 (D)	8.1	4.1	11	343835 ☒	o. r.
		63 (E)	8.1	4.5	20	344117 ☒	344119 ☒
	25	63 (E)	13.0	4.5	11	342307 ☒	343965 ☒
		80 (F)	13.0	5.0	25	343851 ☒	344132 ☒
	32	63 (E)	20.0	4.5	6	343855 ☒	o. r.
		80 (F)	20.0	5.0	14	343859 ☒	344137 ☒
	40	80 (F)	31.0	5.0	9	343864 ☒	o. r.
		125 (H)	31.0	3.2	25	343869 ☒	344163 ☒
	50	100 (G)	45.0	4.4	7.2	346199 ☒	359741 ☒
		125 (H)	45.0	3.2	10	344071 ☒	344178 ☒
	65	125 (H)	73.0	5.7	12	344183 ☒	344185 ☒
		175 (K)	73.0	4.5	16 (15 ^{3.)})	344184 ☒	o. r.
	80	125 (H)	110.0	5.7	7.5	343951 ☒	344190 ☒
		175 (K)	110.0	4.5	10	344188 ☒	o. r.
		225 (L)	110.0	3.3	16 (12.5 ^{3.)})	344189 ☒	o. r.
100	125 (H)	165.0	5.7	5	344195 ☒	344197 ☒	
	175 (K)	155.0	4.5	7.0	344193 ☒	o. r.	
	225 (L)	155.0	4.8	16 (10 ^{3.)})	344194 ☒	o. r.	

o. r. = on request

1.) Further information can be found in chapter "3. Control functions" on page 6.

2.) Further information can be found in chapter "Pilot pressure diagram with flow direction below seat (control function B)" on page 15.

3.) According to pressure equipment directive 2014/68/EU for compressible fluids of group 1 (dangerous gases and vapours according to article 4, paragraph (1), c), i), first indent)

Further versions on request	
Approval Food processing, drinking water, oxygen, fuel gases, explosion protection	Pressure Other variants for operating pressures up to 25 bar(g) Vacuum version down to -0.9 bar(g)
Material Seal: NBR, FKM, EPDM	Temperature High temperature version up to +230 °C Hot water version up to +200 °C Low temperature version down to -40 °C
Process connection Clamp connection, threaded connection, welded connection	

DTS 1000010970 EN Version: AH Status: RL (released | freigegeben | valide) printed: 20.03.2024

Valves with flow direction above seat

Note:

There is a risk of water hammer!

Control function	Nominal diameter (port connection) DN	Actuator size Ø [mm]	K _v value water [m³/h]	Pilot pressure min. [bar(g)]	Operating pressure max. [bar(g)]	Article no.	
						PA actuator	PPS actuator
DIN EN 1092 - 1						Stainless steel body	
A (CF A) see control functions ^{1.)}	10	40 (C)	4.7	See footnote ^{2.)}	16	344092	o. r.
		50 (D)	4.7		16	343899	343911
	15	40 (C)	4.7		16	344112	o. r.
		50 (D)	4.7		16	343900	342699
	20	40 (C)	8.1		16	343902	o. r.
		50 (D)	8.1		16	343903	343913
	25	50 (D)	12.0		16	343905	343914
	32	63 (E)	20.0,		16	344138	343916
	40	80 (F)	31.0		16	342648	344165
	50	80 (F)	45.0		16	341405	343917
	65	125 (H)	73.0		10	343941	o. r.
	80	125 (H)	110.0		10	343943	o. r.
	100	125 (H)	165.0		6	342703	o. r.

o. r. = on request

1.) Further information can be found in chapter "3. Control functions" on page 6.

2.) Further information can be found in chapter "Pilot pressure diagram for flow direction above seat (control function A)" on page 17.

Further versions on request	
<p>Approval Food processing, drinking water, oxygen, fuel gases, explosion protection</p>	<p>Pressure Other versions for operating pressures up to 25 bar(g) Vacuum variant down to -0.9 bar(g)</p>
<p>Material Seal: NBR, FKM, EPDM</p>	<p>Temperature High temperature variant up to +230 °C Hot water variant up to +200 °C Low temperature variant down to -40 °C</p>
<p>Process connection Clamp connection, threaded connection, welded connection</p>	

DTS 1000010970 EN Version: AH Status: RL (released | freigegeben | validé) printed: 20.03.2024

10.5. Ordering chart thread connection

Valves with flow direction below seat

Note:

Other variants are available on request.

Control function	Nominal diameter (port connection)	Threaded connection	Actuator size Ø	K _v value water	Pilot pressure min.	Operating pressure max.	Article no.	
							PA actuator	PPS actuator
	DN	[mm]	[m³/h]	[bar(g)]	[bar(g)]	Stainless steel body		
A (CF A) see control functions ^{1.)}	10	G 3/8	40 (C)	4.7	4.0	15	343815	343833
			50 (D)	4.7	4.1	16	343819	344098
	15	G 1/2	40 (C)	4.7	4.0	15	344100	o. r.
			50 (D)	4.7	4.1	16	343901	344102
	20	G 3/4	40 (C)	8.1	4.0	6.5	343833	o. r.
			50 (D)	8.1	4.1	11	343836	o. r.
			63 (E)	8.1	4.5	20	344121	344122
	25	G 1	63 (E)	13.0	4.5	11	343846	o. r.
			80 (F)	13.0	5.0	25	343852	344133
	32	G 1 1/4	63 (E)	20.0	4.5	6	343856	o. r.
			80 (F)	20.0	5.0	14	343860	o. r.
	40	G 1 1/2	80 (F)	31.0	5.0	9	344172	o. r.
			125 (H)	31.0	3.2	16	343870	343894
	50	G 2	100 (G)	45.0	4.4	7.2	342873	o. r.
			125 (H)	45.0	3.2	10	343880	343896
	65	G 2 1/2	125 (H)	65.0	5.7	12	343921	344187
175 (K)			65.0	4.5	16 (15 ^{2.)})	344186	o. r.	

o. r. = on request

1.) Further information can be found in chapter "3. Control functions" on page 6.

2.) According to pressure equipment directive 2014/68/EU for compressible fluids of group 1 (dangerous gases and vapours according to article 4, paragraph (1), c), i), first indent)

Further versions on request	
Approval Food processing, drinking water, oxygen, fuel gases, explosion protection	Pressure Other variants for operating pressures up to 25 bar(g) Vacuum variant down to -0.9 bar(g)
Material Seal: NBR, FKM, EPDM	Temperature High temperature variant up to +230 °C Hot water variant up to +200 °C Low temperature variant down to -40 °C
Process connection Clamp connection, threaded connection, flange connection	

DTS 1000010970 EN Version: AH Status: RL (released | freigegeben | valide) printed: 20.03.2024

Valves with flow direction above seat

Note:

There is a risk of a pressure surge.

Control function	Nominal diameter (port connection)	Threaded connection	Actuator size Ø [mm]	K _v value water [m³/h]	Pilot pressure min. [bar(g)]	Operating pressure max. [bar(g)]	Article no.	
	DN						PA actuator	PPS actuator
A (CF A) see control functions ¹⁾	10	G 3/8	40 (C)	4.7	See footnote ²⁾	16	20020021	o. r.
			50 (D)	4.7		16	20020075	o. r.
	15	G 1/2	40 (C)	4.7		16	20020080	o. r.
			50 (D)	4.7		16	341406	o. r.
	20	G 3/4	40 (C)	8.1		16	20020091	o. r.
			50 (D)	8.1		16	374604	o. r.
	25	G 1	50 (D)	12.0		16	343906	343915
	32	G 1/4	63 (E)	20.0		16	346131	o. r.
	40	G 1 1/2	80 (F)	31.0		16	20020097	o. r.
	50	G 2	80 (F)	45.0		16	343910	o. r.
	65	G 2 1/2	125 (H)	65.0		10	20020103	o. r.

o. r. = on request

1.) Further information can be found in chapter "3. Control functions" on page 6.

2.) Further information can be found in chapter "Pilot pressure diagram for flow direction above seat (control function A)" on page 17.

Further versions on request	
Approval Food processing, drinking water, oxygen, fuel gases, explosion protection	Pressure Other variants for operating pressures up to 25 bar(g) Vacuum variant down to -0.9 bar(g)
Material Seal: NBR, FKM, EPDM	Temperature High temperature variant up to +230 °C Hot water variant up to +200 °C Low temperature variant down to -40 °C
Process connection Clamp connection, threaded connection, flange connection	

DTS 1000010970 EN Version: AH Status: RL (released | freigegeben | validé) printed: 20.03.2024

10.6. Ordering chart welded connection

Valves with flow direction below seat

Control function	Nominal diameter (port connection)	Welded connection external Ø x WS	Actuator size Ø	K _v value water	Pilot pressure min.	Operating pressure max.	Article no.	
	DN						[mm]	[mm]
DIN EN ISO 1127 / ISO 4200							Stainless steel body	
A (CF A) see control functions ¹⁾	10	17.2 × 1.6	40 (C)	4.7	4.0	15	343816	o. r.
			50 (D)	4.7	4.1	16	343820	343884
	15	21.3 × 1.6	40 (C)	4.7	4.0	15	343824	o. r.
			50 (D)	4.7	4.1	16	343830	343886
	20	26.9 × 1.6	40 (C)	8.1	4.0	6.5	343834	o. r.
			50 (D)	8.1	4.1	11	343837	o. r.
			63 (E)	8.1	4.5	20	343843	343888
	25	33.7 × 2.0	63 (E)	13.0	4.5	11	343847	o. r.
			80 (F)	13.0	5.0	25	343853	343890
	32	42.4 × 2.0	63 (E)	20.0	4.5	6	343857	o. r.
			80 (F)	20.0	5.0	14	343861	343893
	40	48.3 × 2.0	80 (F)	31.0	5.0	9	343865	o. r.
			125 (H)	31.0	3.2	16	343871	343895
	50	60.3 × 2.0	100 (G)	45.0	4.4	7.2	343875	o. r.
			125 (H)	45.0	3.2	10	343881	343897
	65	76.1 × 2.3	125 (H)	73.0	5.7	12	343922	343956
			175 (K)	73.0	4.5	16 (15 ²⁾)	343827	o. r.
	80	88.9 × 2.3	125 (H)	110.0	5.7	7.5	343952	343959
			175 (K)	110.0	4.5	10	343932	o. r.
			225 (L)	110.0	4.8	25 (12.5 ²⁾)	343934	o. r.
100	114.3 × 2.6	125 (H)	165.0	5.7	5	343954	343961	
		175 (K)	155.0	4.5	7.0	343937	o. r.	
		225 (L)	155.0	4.8	16 (10 ²⁾)	343939	o. r.	

DTS 1000010970 EN Version: AH Status: RL (released | freigegeben | valide) printed: 20.03.2024



Control function	Nominal diameter (port connection)	Welded connection external Ø x WS	Actuator size Ø	K _v value water	Pilot pressure min.	Operating pressure max.	Article no.	
	DN	[mm]	[mm]	[m ³ /h]	[bar(g)]	[bar(g)]	PA actuator	PPS actuator
DIN 11850 series 2							Stainless steel body	
A (CF A) see control functions ¹⁾	10	13 × 1.5	40 (C)	4.7	4.0	15	343817	o. r.
			50 (D)	4.7	4.1	16	343821	343885
	15	19 × 1.5	40 (C)	4.7	4.0	15	343825	o. r.
			50 (D)	4.7	4.1	16	343831	343887
	20	23 × 1.5	40 (C)	8.1	4.0	6.5	o. r.	o. r.
			50 (D)	8.1	4.1	11	343838	o. r.
			63 (E)	8.1	4.5	20	343844	343889
	25	29 × 1.5	63 (E)	13.0	4.5	11	o. r.	o. r.
			80 (F)	13.0	5.0	25	343854	343891
	32	35 × 1.5	63 (E)	20.0	4.5	6	343858	o. r.
			80 (F)	20.0	5.0	14	343862	o. r.
	40	41 × 1.5	80 (F)	31.0	5.0	9	343866	o. r.
			125 (H)	31.0	3.2	16	343872	344087
	50	53 × 1.5	100 (G)	45.0	4.4	7.2	343876	o. r.
			125 (H)	45.0	3.2	10	343882	343898
	65	70.0 × 2.0	125 (H)	73.0	5.7	12	343923	343958
			175 (K)	73.0	4.5	16 (15 ²⁾)	343928	o. r.
	80	85.0 × 2.0	125 (H)	110.0	5.7	7.5	343953	343960
175 (K)			110.0	4.5	10	343933	o. r.	
225 (L)			110.0	4.8	25 (12.5 ²⁾)	343936	o. r.	
100	104.0 × 2.0	125 (H)	165.0	5.7	5	343955	343962	
		175 (K)	155.0	4.5	7.0	343938	o. r.	
		225 (L)	155.0	4.8	16 (10 ²⁾)	343940	o. r.	

o. r. = on request

1.) Further information can be found in chapter "3. Control functions" on page 6.

2.) According to pressure equipment directive 2014/68/EU for compressible fluids of group 1 (dangerous gases and vapours according to article 4, paragraph (1), c), i), first indent)

Further versions on request	
<p>Approval Food processing, drinking water, oxygen, fuel gases, explosion protection</p>	<p>Pressure Other variants for operating pressures up to 25 bar(g) Vacuum variant down to -0.9 bar(g)</p>
<p>Material Seal: NBR, FKM, EPDM</p>	<p>Temperature High temperature variant up to +230 °C Hot water variant up to +200 °C Low temperature variant down to -40 °C</p>
<p>Process connection Clamp connection, threaded connection, flange connection</p>	

DTS 1000010970 EN Version: AH Status: RL (released | freigegeben | valide) printed: 20.03.2024

Valves with flow direction above seat

Note:

Valves with flow direction above the seat are only conditionally suitable for liquid mediums. There is a risk of a pressure surge.

Control function	Nominal diameter (port connection)	Welded connection external Ø x WS	Actuator size Ø	K _v value water	Pilot pressure min.	Operating pressure max.	Article no.	
	DN	[mm]	[mm]	[m³/h]	[bar(g)]	[bar(g)]	PA actuator	PPS actuator
DIN EN ISO 1127 / ISO 4200							Stainless steel body	
A (CF A) see control functions ¹⁾	10	17.2 x 1.6	40 (C)	4.7	See footnote ²⁾	16	342653	o. r.
			50 (D)	4.7		16	20020146	o. r.
	15	21.3 x 1.6	40 (C)	4.7		16	20020156	o. r.
			50 (D)	4.7		16	20020161	o. r.
	20	26.9 x 1.6	40 (C)	8.1		16	20020168	o. r.
			50 (D)	8.1		16	343904	o. r.
	25	33.7 x 2.0	50 (D)	12.0		16	343907	o. r.
			63 (E)	20.0		16	20020175	o. r.
	40	48.3 x 2.0	80 (F)	31.0		16	346297	o. r.
			80 (F)	45.0		16	20020179	o. r.
	65	76.1 x 2.3	125 (H)	73.0		10	20020186	o. r.
			125 (H)	110.0		10	343945	o. r.
100	114.3 x 2.6	125 (H)	165.0	6	343948	o. r.		
DIN 11850 series 2								
A (CF A) see control functions ¹⁾	10	13 x 1.5	40 (C)	4.7	See footnote ²⁾	16	20020191	o. r.
			50 (D)	4.7		16	20020198	o. r.
	15	19 x 1.5	40 (C)	4.7		16	20020202	o. r.
			50 (D)	4.7		16	346118	o. r.
	20	23 x 1.5	40 (C)	8.1		16	20020211	o. r.
			50 (D)	8.1		16	20020216	o. r.
	25	29 x 1.5	50 (D)	12.0		16	20011741	o. r.
			63 (E)	20.0		16	20020217	o. r.
	40	41 x 1.5	80 (F)	31.0		16	20020218	o. r.
			80 (F)	45.0		16	379466	o. r.
	65	70.0 x 2.0	125 (H)	73.0		10	343942	o. r.
			125 (H)	110.0		10	343946	o. r.
100	104.0 x 2.0	125 (H)	165.0	6	343949	o. r.		

o. r. = on request

1.) Further information can be found in chapter "3. Control functions" on page 6.

2.) Further information can be found in chapter "Pilot pressure diagram for flow direction above seat (control function A)" on page 17.

Further versions on request	
Approval Food processing, drinking water, oxygen, fuel gases, explosion protection	Pressure Other variants for operating pressures up to 25 bar(g) Vacuum variant down to -0.9 bar(g)
Material Seal: NBR, FKM, EPDM	Temperature High temperature variant up to +230 °C Hot water variant up to +200 °C Low temperature variant down to -40 °C
Process connection Clamp connection, threaded connection, flange connection	

DTS 1000010970 EN Version: AH Status: RL (released | freigegeben | valide) printed: 20.03.2024

10.7. Ordering chart accessories

Accessories for 3/2-way pilot valve with banjo bolts

Note:

- Seal material FKM / NBR
- For complete program see **data sheet Type 6012 ▶, Type 6014 ▶, Type 2507 ▶, Type 2518 ▶**

Valve for Actuator size Ø	Type	Pilot air ports	Working port (banjo bolt)	Q _{Nn} value air	Pressure range	Electrical coil connection Industry standard	Power consumption	Article no.			
								Voltage/Frequency		Cable plug	
								024 V DC	230 V/50	12...24 AC/DC with LED	0...250 AC/DC
[mm]				[l/min]	[bar(g)]		[W]	[V]	[V]	[V]	[V]
40 (C)	6012P	Thread G ¼	Thread G ⅛	48	0...10	Type 2507 Form B	4	552295	552298	423849	423845
		Push-in connector Ø 6 mm						552287	552286		
		Thread G ¼	Thread G ¼					552291	552294		
		Push-in connector Ø 6 mm						552283	552286		
50 (D)... 63 (E)											
50 (D)... 125 (H)	6014P	Thread G ¼	Thread G ¼	120	0...10	Type 2518 Form A	8	424103	424107	314812	314802
175 (K)... 225 (L)	6014P	G ¼	G ⅛	174	0...6	Type 2518 Form A	8	786014	786015	314812	314802

DTS 1000010970 EN Version: AH Status: RL (released | freigegeben | validé) printed: 20.03.2024

