

Datasheet
Battery powered electromagnetic flow meter
LDG series



Datasheet

Electromagnetic flow meter for flow measurement LDG-DNXX flow meter

Supmea's electromagnetic flow meter does not contain any moving parts, rotating gears or turbines, or bearings. Instead, it relies on two electrodes to measure the density of the induced magnetic field that results from an electrically conductive fluid, such as water, flowing through a pipe. So there is no susceptibility to bearing wear or other mechanical wear-and-tear issues.

As for the electrodes and the liner used in electromagnetic flow meter, these components can be fabricated from a variety of materials to make the mag meter compatible with virtually various electrically conductive fluid, including aggressive acids.

The only limitation of the electromagnetic flow meter is that the measured fluid media must be electrically conductive ($> 5\mu\text{S}/\text{cm}$). Non-conductive fluids, such as oil and other petroleum-based fluids, cannot be measured with mag meter technology.

Application

- Sewage treatment
- printing and dyeing
- Chemical industry
- Environmental protection
- metallurgy
- medicine
- papermaking
- Tap water supply

Features

PROS

- Battery life more than 6 years
- Path type structure design;
- No moving parts inside the sensor
- Dual ground electrode design
- The upper flow velocity can reach 12m/s
- Pressure loss $< 2\text{kPa}$



Electromagnetic flow meter

Principle

The measurement principle of magnetic flowmeters can be described as follows: when the liquid goes through the pipe at the flow rate of v with a diameter D , within which a magnetic flux density of B is created by an exciting coil, the following electromotive E is generated in proportion to flow speed v :

$$E = K \times B \times V \times D$$

Where:

- E —Induced electromotive force
- K —Meter constant
- B —Magnetic induction density
- V —Average flow speed in cross-section of measuring tube
- D —Inner diameter of measuring tube

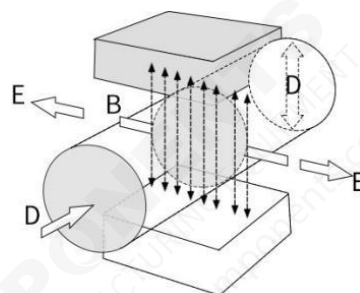

The signal voltage U is obtained by electrodes on both sides of the sensor and is proportional to the fluid flow rate and therefore the fluid flow rate. The signal is amplified, filtered and then accumulated, recorded and output.

Parameters

Features	
Features	Circular conical measuring tube; Lining: Neoprene; Maximum flow rate up to 12m/s, Pressure consumption: <2kPa
Diameter	DN50 -DN1200
Display and User Interface	
Display	Segment LCD
Button	1 magnetic control button; Menu operation via magnetic buttons without opening the converter housing
Display information	Forward and reverse accumulation, Instantaneous flow, Weak signal alarm, Off excitation alarm, Empty pipe alarm, Time, Date, Battery level indicator
Shipping packing	Lead seal
Communication	RS485, GPRS, NB-IoK 4G
Measurement	
Units of measurement	Instantaneous flow: m ³ /h Accumulation: m ³
Measurement interval	default setting: 15s optional: 1s, 5s, 15s, 25s
Empty pipe detection	Optional: Display "empty pipe" alarm in empty pipe state
Low flow excision	When the flow rate is lower than the low flow cutoff value, the accumulative amount does not accumulate
Measurement accuracy	
Reference conditions	0.1°C-50°C Conductivity: >20μS/cm
Measurement error	V>0.6m/s, ±0.5%; V<0.6m/s, ±0.5%±2mm/s
Repeatability	0.16% (flow rate V>0.6m/s)
Calibration	Each meter is calibrated at the factory
Installation conditions	
Installation	Make sure the sensor is always full
Flow direction	The positive direction is when the flow direction is consistent with the flow direction on the sensor
Inlet straight pipe	>5DN
Outlet straight pipe	>3DN
Dimensions and Weight	For more details, please refer to the following chapter "Dimensions and Weights"

Operating conditions

Temperature	Process temperature: +0.1°C~+50°C Ambient temperature: -40°C~+65°C (Ambient temperature below -25°C may affect the LCD display) Storage temperature: -50°C~+70°C
Upper flow rate	12m/s
Initial flow rate	10mm/s
Flange pressure (GB/T 9119-2010)	DN50~DN150: PN16 DN200~DN600: PN10 DN700~DN1200: PN6
Pressure consumption	<2kPa
Measuring medium	Drinking water, raw water, irrigation water
Conductivity	>20 μS/cm

Material

Sensor shell	Carbon steel, 304 stainless steel
Diameter	DN50 ~DN1200
Measuring tube material	316 stainless steel
Flange	Carbon steel, 304 stainless steel
Lining	Neoprene
Measuring electrodes	316L stainless steel(Standard) Optional HC
Ground electrode	316L stainless steel(Standard) Optional HC
Ground ring	Optional, material: 304 stainless steel
Converter shell	304 stainless steel

Electrical interface

Cable connection	
Cable access	Aviation connector, transfer box 3m cable (with aviation connector/male), If need to lengthen, please note;
Power supply	
Battery	4 4 lithium batteries (3.6V, 76A-h): flow; 2 lithium batteries (3.6V, 38A - h): data collector; Reserve external battery power supply, 24VDC power supply interface
Battery alarm	Low battery alarm: battery symbol flashes
Battery replacement	Parameters are not lost

Measuring range			
DN(mm)	Flow range(rrf/h)	DN(mm)	Flow range(m3/h)
50	0.28 ~70.65	400	18.09 ~4521.60
80	0.72 ~180.86	500	28.26~7065.00
100	1.13 ~282.60	600	40.69~10173.60
150	2.54 ~635.85	700	55.39~13847.40
200	4.52 ~1130.40	800	72.35~18086.40
250	7.07 ~1766.25	900	91.56 ~22890.60
300	10.17~2543.40	1000	113.04 ~28260.00
350	13.85~3461.85	1200	162.78~40694.40

Measurement accuracy		
Standard calibration		
DN(mm)	Flow velocity V(m/s)	Relative error
50 ~1200	V<0.6	±0.5%±0.002/V
	0.6<V<12	±0.5%

The converter adopts IP68, modular design, and the components are shown in the following table:



No	Part Name	Note
①	Dust cover	
②	Protective cover	Lead seal design, Demolition is a sabotage job
③	Metal cover	Stainless steel
④	PCB module	With battery module
⑤	Adapter Board Module	IP68
⑥	Metal lower shell	Stainless steel
⑦	Electromagnetic sensor	

Dimension

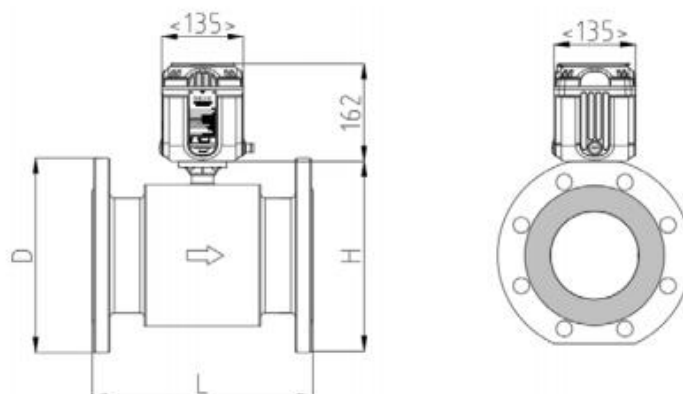

DN(mm)	Rated pressure(MPa)	L (mm)	Reference Size H (mm)	D (mm)	Weight
50	1.6	200	150	165	15
80	1.6	200	180	200	21
100	1.6	250	200	220	25
150	1.6	300	271	285	34
200	1.0	350	316	340	48
250	1.0	450	375	395	71
300	1.0	500	422	445	73
350	1.0	500	512	505	91
400	1.0	600	578	565	121
450	1.0	600	615	615	145
500	1.0	600	655	670	169
600	1.0	600	735	780	271
700	0.6	700	830	860	288
800	0.6	800	988	975	363
900	0.6	900	1062	1075	483
1000	0.6	1000	1196	1175	528
1200	0.6	1200	1395	1405	633

Wiring

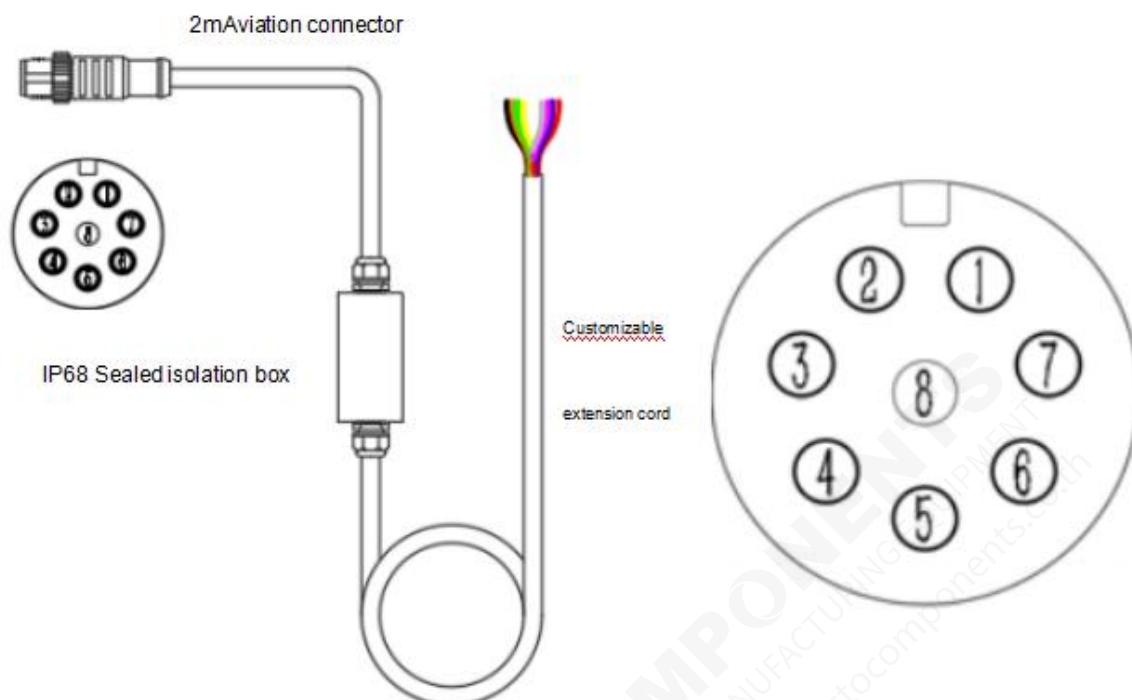

No	Colour	Connection code
1	White	RS485-A
2	Brown	RS485-B
3	Green	AGND
4	Yellow	YYG+
5	Grey	YYDS+
6	Pink	24V+
7	Blue	Fr+
8	Red	Fr-

Ordering code

LDG-DNXX-D1-PA1-AI1-V1					Description
LDG	-	-	-	-	
Nominal Diameter	DNXX				40-1200
Communication		D1			Non
		D2			GPS
		D3			NB-IoT
		D4			4G
		D5			Others optional
Pressure Acquisition			PA1		Non
			PA2		With pressure ball valve, without pressure sensor
			PA3		With pressure ball valve, with pressure sensor
Antenna Installation				A11	Integrated antenna
				A12	Split antenna(standard)
Power supply				V1	Dual power supply (3.6V lithium battery +24V.DC)

FACTOCOMPONENTS
 INDUSTRIAL SUPPLIES AND MANUFACTURING
 02-384-6060 | info@factocomponents.co.th | www.factocomponents.co.th