



FC
FACTOCOMPONENTS
 INDUSTRIAL SUPPLIES AND MANUFACTURING EQUIPMENT

By-Pass Level Transmitter



Innovation · Quality · Sharing

INTRODUCTION

The By-Pass Level Indicator is installed outside of a vessel or tank. The liquid level in the tank can easily be observed from the change of the flag color. Optional devices of magnetic switch and level transducer can be added for electrical signal output and level transmitting.

PRINCIPLE

Fine-Tek's By-Pass indicator utilizes hydrostatic principle to show the liquid level in the tank. A float with a magnet inside rises and drops according to the liquid level change. Magnetic flags will flip as float passes through to indicate liquid level based on magnetic attraction method.

APPLICATIONS AND FEATURES

- Applicable in environment with high temp., high pressure, strong acid, strong alkaline and hazardous locations. The structure is simple but durable and reliable. It is also available with various options for upgrade.
- A level transducer or magnetic switch can be installed and adjusted during operation.
- It is not operated by electricity thus it will not be affected by power failure.
- Add different color of flag per 10cm that can be recognized easily.
- Multiple applications for textile dyeing, sewage water processing, power generating, boiler and petrochemical industries.

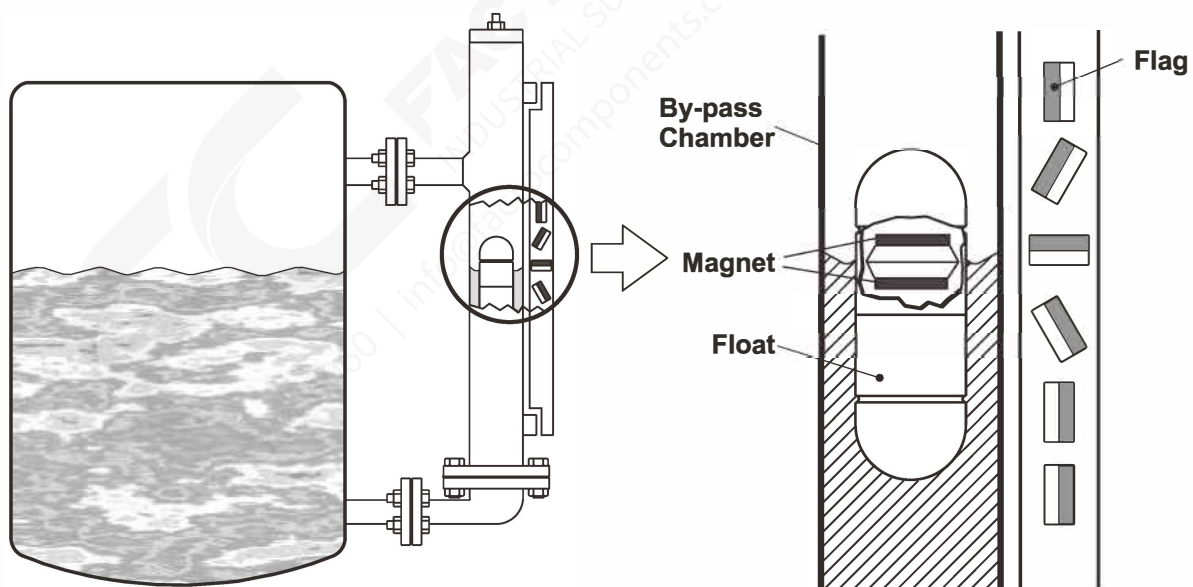

1.) Magnetic Switch (Fig.1)

- * The plastic miniature magnetic switch is anti-corrosive and with IP67 rating. It is the smallest magnetic switch in the current market.
- * The magnetic switch is easy to set up and has real time adjustment.

2.) Innovative Design For Bottom End Flange and the Connecting Flange (Fig.2)

- * The lower center duct is at the bottom end of the chamber.
- When the liquid drains in the tank, there will be no residue in the chamber unit.
- * This is suitable for production that requires frequent liquid change and mixture is not allowed during the process.

3.) Removable Duct and Connecting Flange (Fig.3)

- * The flange setting is close to the two ends of the chamber, therefore the "C-C" distance is maximized.
- * It is strengthened in the structure by a large phase weld.
- * During the installation, adjust the flange to the fitting mounting holes.

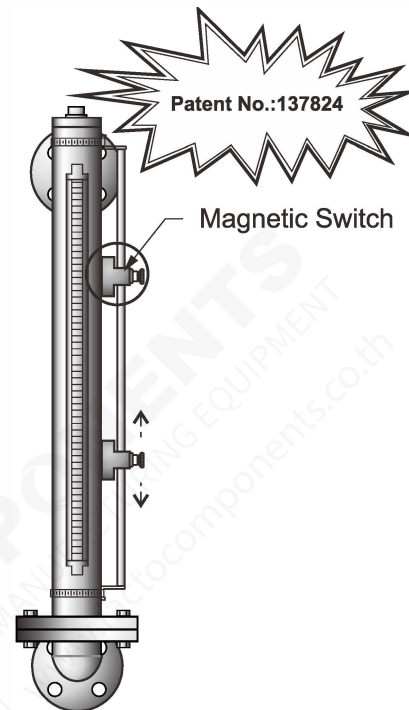

Fig.1

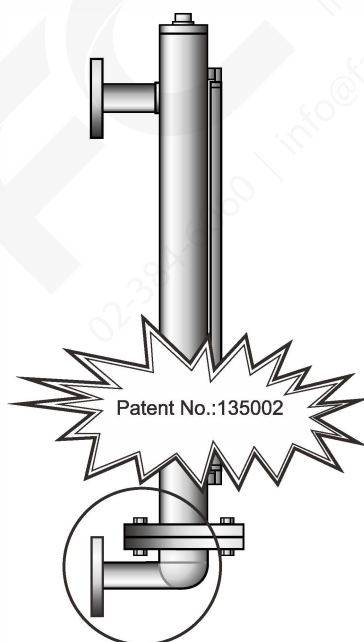

Fig.2

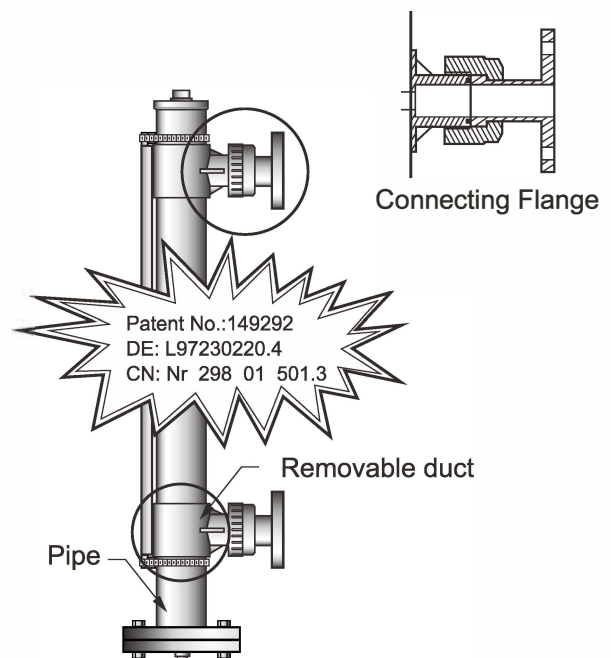
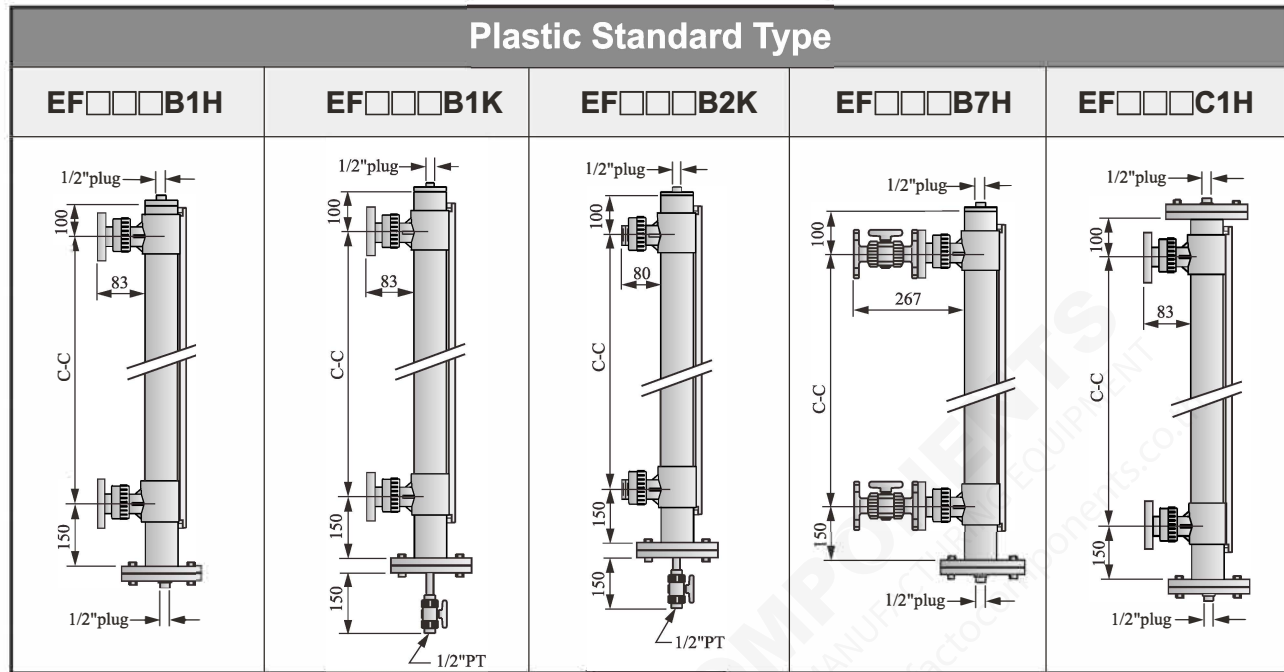

Fig.3

SPECIFICATIONS



SPECIFICATIONS:

Model No.	EF□□□B1H	EF□□□B1K	EF□□□B2K	EF□□□B7H	EF□□□C1H
Description					
Top end	Flat top with 1/2"PT plug				Dual flange with 1/2"PT plug
Bottom end	Dual flange with 1/2"PT plug	Dual flange with 1/2"PT drain valve		Dual flange with 1/2"PT plug	
Connecting	3/4" x10kg/cm ² (Flange)		3/4" or 1"PT (Screw)	3/4" x10kg/cm ² (Ball Valve)	3/4" x10kg/cm ² (Flange)
C-C Distance	Min. 150mm; Max. 3800mm				
Operation pressure	5kg/cm ²				
Operation temp.	PP: 80°C, PVDF: 120°C				
Chamber	PP: φ60.5 x 3.8t, PVDF: φ63 x 3.2t				
Float type	EFB-2500 (PVDF) / 2510 (PP) (Refer float specifications)				
Material	PP / PVDF				
Flag indicator	EFB-0750 (140°C) (Refer flag display data)				
Ruler	Option(Refer ruler data)				

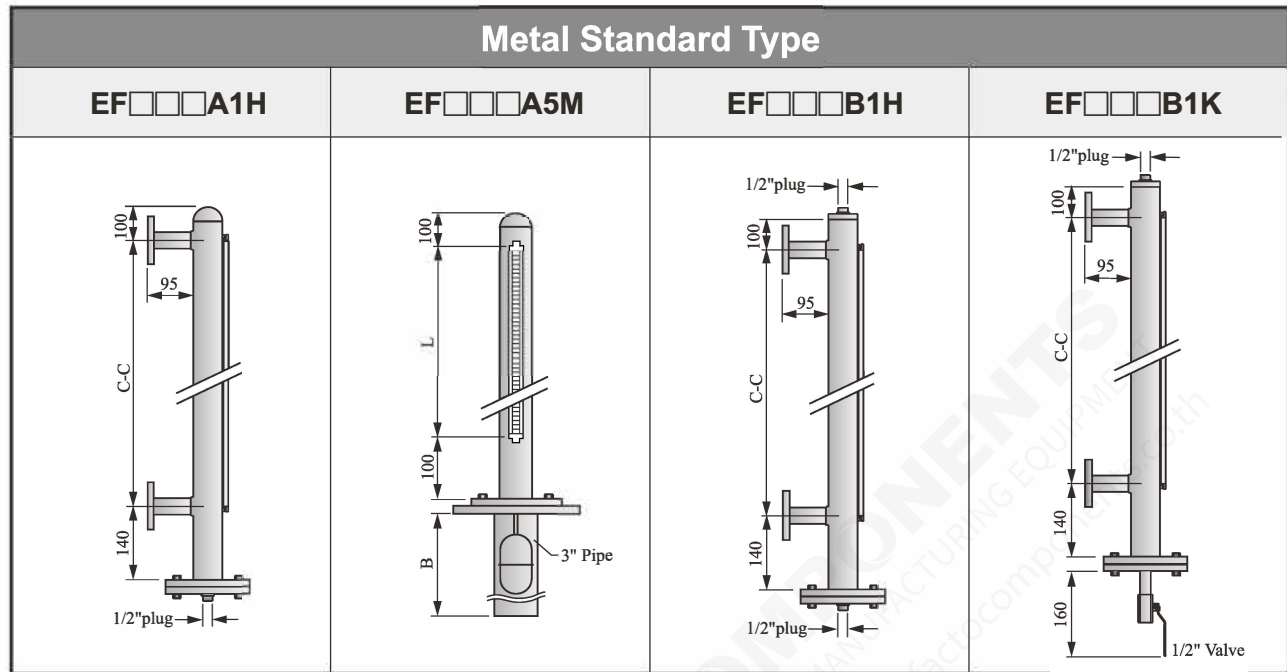

SPECIFICATIONS

Model No. Description	EF□□□A1H	EF□□□A5M	EF□□□B1H	EF□□□B1K
Top end	Cap		Flat top with 1/2"PT plug	
Bottom end	Dual flange with 1/2"PT plug	Dual flange with 3" shield pipe	Dual flange with 1/2"PT plug	Dual flange with 1/2" drain valve
Bottom flange	1-1/2" x 5kg/cm ²		1-1/2" x 5kg/cm ²	
Connecting	3/4" x 10kg/cm ² (Flange)		3/4" x 10kg/cm ² (Flange)	
C-C Distance Flag isplay length(L)	Min. 150mm; Max. 5,800mm	Min. 150mm; Max. 2,000mm	Min. 150mm; Max. 5.800mm	
Operation pressure	25kg/cm ² (Max. 50kg/cm ²)			20kg/cm ²
Operation temp.	SUS304: 140°C, 200°C, 400°C SUS316: 140°C, 200°C, 400°C			SUS304: 140°C, 200°C, 350°C SUS316: 140°C, 200°C, 350°C
Chamber	φ60.5 x 2.8t			
Float type	EFB-2580 (Refer float specifications)			
Material	SUS304 / SUS316			
Flag indicator	EFB-0700 (200°C), EFB-0740 (400°C), EFB-0750 (140°C)(Refer flag display data)			
Ruler	Option (Refer ruler data)			

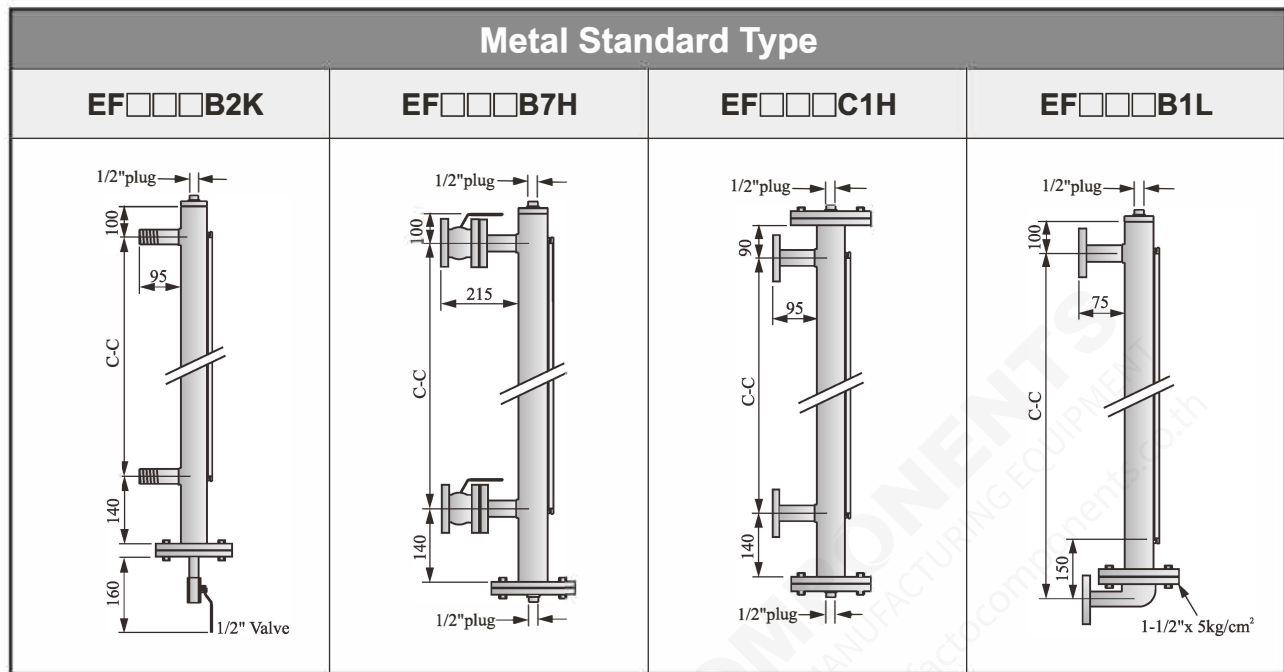

* The pipe is so long that support rack is needed to prevent pipe from bending.

SPECIFICATIONS

Model No.	EF□□□B2K	EF□□□B7H	EF□□□C1H	EF□□□B1L
Description	EF□□□B2K	EF□□□B7H	EF□□□C1H	EF□□□B1L
Top end	Flat top with 1/2"PT plug		Dual flange with 1/2"PT plug	Flat top with 1/2"PT plug
Bottom end	Dual flange with 1/2" drain valve	Dual flange with 1/2"PT plug		Dual flange+angle pipe
Bottom flange	1-1/2" x 5kg/cm ²			—
Connecting	3/4"PT or 1"PT (Screw)	3/4" x10kg/cm ² (Ball Valve)	3/4" x10kg/cm ² (Flange)	
C-C Distance	Min. 150mm; Max. 5,800mm			
Operation pressure	20kg/cm ²	10kg/cm ²	25kg/cm ² (Max. 50kg/cm ²)	
Operation temp.	SUS304:140°C, 200°C, 350°C SUS316:140°C, 200°C, 350°C		SUS304:140°C, 200°C,400°C SUS316:140°C, 200°C,400°C	
Chamber	φ60.5 x 2.8t			
Float type	EFB-2580 (Refer float specifications)			
Material	SUS304 / SUS316			
Flag indicator	EFB-0700 (200°C), EFB-0740 (400°C), EFB-0750 (140°C) (Refer flag display data)			
Ruler	Option (Refer ruler data)			

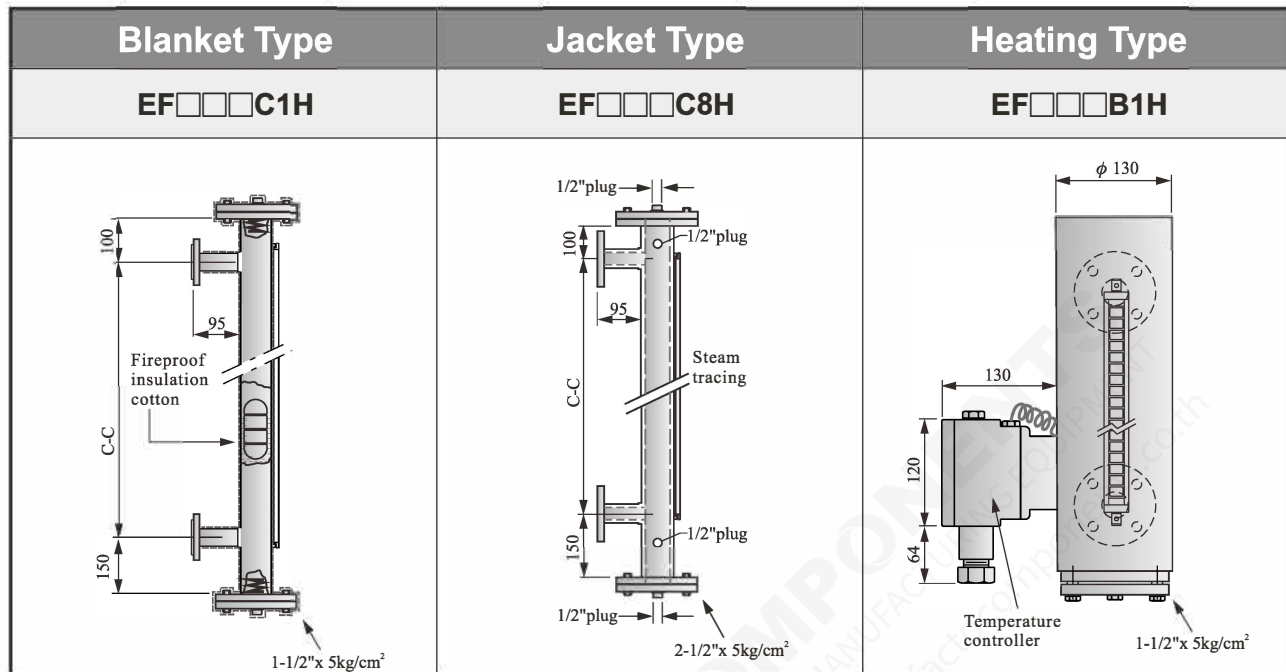

SPECIFICATIONS

Model No.	EF□□□C1H	EF□A/B□C1H	EF□□□B1H
Description			
Top end	Dual flange with 1/2"PT plug		Dual flange with 1/2"PT plug
Bottom end	Dual flange with 1/2"PT plug		Dual flange with 1/2"PT plug
Connecting	3/4" x10kg/cm ² (Flange)	1-1/4" x 10kg/cm ²	3/4" x10kg/cm ² (Flange)
C-C Distance	Min. 150mm; Max. 5800mm		
Operation pressure	25kg/cm ² (Max. 50kg/cm ²)		20kg/cm ²
Operation temp.	SUS304: 140°C, 200°C, 400°C SUS316: 140°C, 200°C, 400°C		SUS304: 100°C SUS316: 100°C
Chamber	φ60.5 x 2.8t	Jacket φ76 x 3.0t 1/2"PT plug	φ 65 x 3.5t φ130 Heating type
Float type	EFB-2580 (Refer float specifications)		
Material	SUS304 / SUS316		
Flag indicator	EFB-0700 (200°C), EFB-0740 (400°C), EFB-0750 (140°C) (Refer flag display data)		
Ruler	Option (Refer ruler data)		

Antiseptic Type	High Pressure Type
EF□□□C1H	EF□□□C1H

SPECIFICATIONS

Model No. Description	EF□A/B□C1H	EF□□□C1H
Top end	Dual flange	Dual flange with 1/2"PT plug
Bottom end	Dual flange	Dual flange with 1/2"PT plug
Connecting	3/4" x10kg/cm ² (Flange)	600Lb or 300Lb
C-C Distance	Min. 150mm; Max. 3800mm	
Operation pressure	25kg/cm ² (Max. 50kg/cm ²)	100kg/cm ² (300°C down)600Lb 60kg/cm ² (300°C up)300Lb
Operation temp.	PP: 80°C PTFE:120°C	SUS304: 140°C SUS316: 140°C
Chamber	φ65 x 2t Coating PP or PTFE	φ 76.3 x 5.5t
Float type	EFB-2580 (Refer float specifications) +Coating	EFB-2654 (Refer float specifications)
Material	SUS304 / SUS316	
Flag indicator	EFB-0700 (200°C), EFB-0740 (400°C), EFB-0750 (140°C) (Refer flag display data)	
Ruler	Option (Refer ruler data)	

MODEL NUMBER / ORDER CODE COMPARISON TABLE

Plastic Standard Type

Model Number	Order Code
EF□□□B1H	EFX1□□□□-B1C
EF□□□B1K	EFX1□□□□-B1G
EF□□□B2K	EFX1□□□□-B2G
EF□□□B7H	EFX1□□□□-B7C
EF□□□C1H	EFX1□□□□-C1C

Metal Standard Type

Model Number	Order Code
EF□□□A1H	EFX1□□□□-A1C
EF□□□A1L	EFX1□□□□-A1N
EF□□□A5M	EFX1□□□□-A5R
EF□□□B1H	EFX1□□□□-B1C
EF□□□B1K	EFX1□□□□-B1G
EF□□□B2K	EFX1□□□□-B2G
EF□□□B7H	EFX1□□□□-B7C
EF□□□B1H	EFX1□□□□-B1C
EF□□□B1L	EFX1□□□□-B1N

Blanket Type

Model Number	Order Code
EF□□□C1H	EFX1A2□□-C1C

Jacket Type

Model Number	Order Code
EF□□□C8H	EFX1A3□□-C1C

Heating Type

Model Number	Order Code
EF□□□B1H	EFX1A4□□-B1C

Antiseptic Type

Model Number	Order Code
EF□□□C1H	EFX1A1□□-C1C

High Pressure Type

Model Number	Order Code
EF□□□C1H	EFX1□□□□-C1C

Plastic Float

Model Number	Order Code
EFB-2500	FLTBM1F-1245116801
EFB-2510	FLTBM1F-1184915001
EFB-1500-F	FLTBM1F-1245116807
EFB-1510-P	FLTBM1F-1184915004

Metal Float

Model Number	Order Code
EFB-2540	FLTBM1F-1MB5020001
EFB-2560	FLTBM1F-1MB5017503
EFB-2580	FLTBM1F-1MB5015002
EFB-2600	FLTBM1F-1MB5029503
EFB-2592	FLTBM1F-1MB5023001
EFB-2540-9	FLTBM1F-1MC5020001
EFB-2560-9	FLTBM1F-1MC5017501
EFB-2580-9	FLTBM1F-1MC5015001
EFB-2600-9	FLTBM1F-1MC5029501
EFB-1540	FLTBM1F-1MB5020006
EFB-1560	FLTBM1F-1MB5017507
EFB-1580	FLTBM1F-1MB5015016
EFB-1581	FLTBM1F-2MB5009602
EFB-1592	FLTBM1F-1MB5023004
EFB-1600	FLTBM1F-1MB5029504

Titanium Alloy Float

Model Number	Order Code
EFB-2630	FLTBM1F-1MF4821002
EFB-2654	FLTBM1F-1MF6139401
EFB-1630-T	FLTBM1F-1MF4821001

Level Transducer

Model Number	Order Code
EG371BQ00-00AB	EGX1001B-A1AAA5012CMA0000ABAA
EG371BQ00-00A0	EGX1001B-A1AAA5012CMA0000A0AA
EG371BQ00-00B0	EGX1001B-A1AAA5012CMA0000B0AA
TAB-2110	TAX□A1X-0004
EGB-0500	EFXBMIP-MAF0000002

Magnetic Switch

Model Number	Order Code
EFB-1220	EFXBM1P-MHS11
EFB-1230	EFXBM1P-MHS12
EFB-1250	EFXBM1P-MHS21
EFB-1260	EFXBM1P-MHS22
EFB-1300	EFXBM1P-MHS31
EFB-1310	EFXBM1P-MHS32
EFB-1400	EFXBM1P-18S44□□□01
EFB-1410	EFXBM1P-18S45
EFB-1420	EFXBM1P-18S41
EFB-1430	EFXBM1P-18S42
EFB-1440	EFXBM1P-18S44□□□05
EFB-1450	EFXBM1P-18S44□□□07
EFB-1800	EFXBM1P-MHS53

Flag Display

Model Number	Order Code
EFB-0700	EGX□M1D-MA22□□□01
EFB-0740	EGX□M1D-MA22□□□02
EFB-0750	EGX□M1D-MA42□□□01
EFB-0770	EGX□M1D-MA63□□□01

Ruler

Model Number	Order Code
EFA-2111	EFX□M1P-MAR
EFA-2120	
EFA-2130	EFX□M1P-15R
EFA-2140	

INSTALLATION EXAMPLE

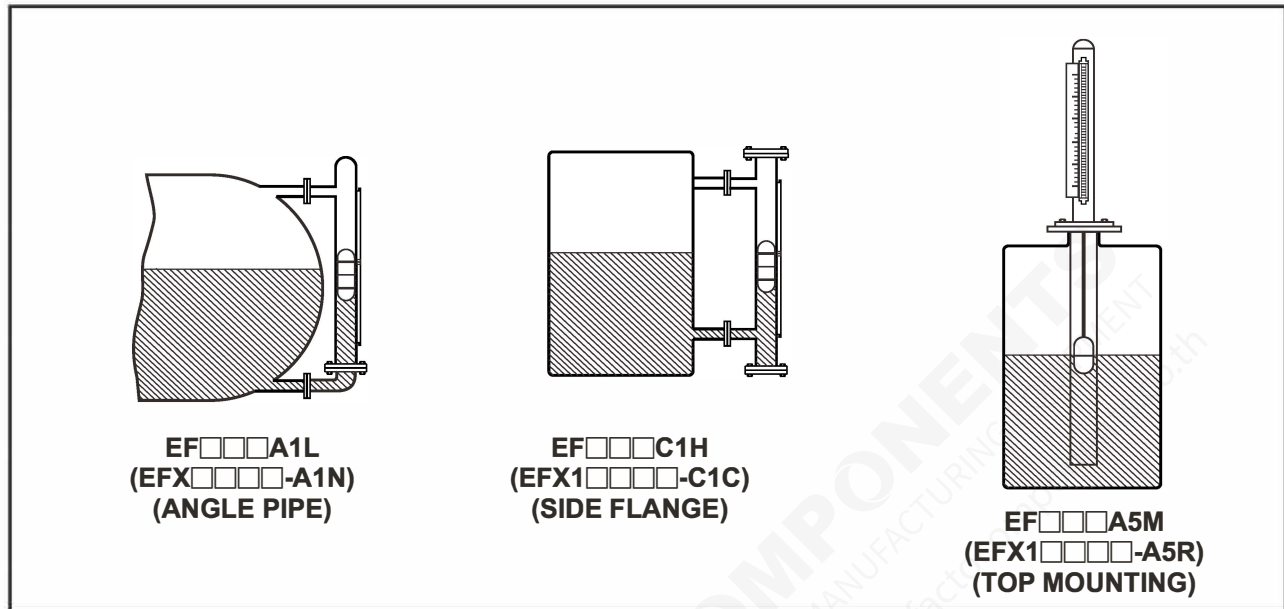

Plastic Float

Code	Order Code	Operation Temp.	Max. Pressure	Dimension	S.G.	Water Immersion Line	Material	Weight
F1	FLT□M1F-1245116801	120°C	5kg/cm ²	OD51*168	0.75	126mm	PVDF	256
F2	FLT□M1F-1245116807	100°C	5kg/cm ²	OD51*168	0.83	126mm	PVDF	256
P1	FLT□M1F-1184915001	80°C	5kg/cm ²	OD49*150	0.7	80mm	PP	188
P2	FLT□M1F-1184915004	80°C	5kg/cm ²	OD49*150	0.63	105mm	PP	188

*Specified S.G. is available made to order.

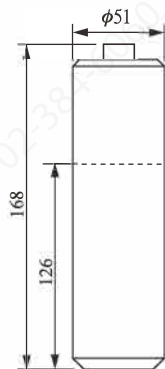

Code: F1 \ F2

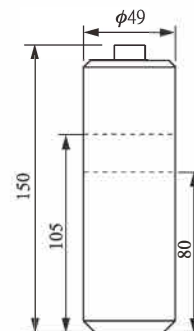

Code: P1 \ P2

FLOAT SPECIFICATIONS

METAL FLOAT

Code	Order Code	Operation Temp.(°C)	Max.Pressure (kg/cm ²)	Dimension (mm)	S.G.	Water Immersion Line	Material	Weight(g)	
M1	FLT□M1F-1MB5020001	400	30	OD50*200	0.7	140	SUS316	234	
M2	FLT□M1F-1MB5017503	400	30	OD50*175	0.75	131		220	
M3	FLT□M1F-1MB5015002	400	40	OD50*150	0.87	130		207	
M4	FLT□M1F-1MB5029503	400	40	OD50*295	0.68	204		330	
M6	FLT□M1F-1MB5023001	200	60	OD50*230	0.72	166	SUS316L	284	
		201~400	45						
L1	FLT□M1F-1MC5020001	400	30	OD50*200	0.7	140		SUS316L	234
L2	FLT□M1F-1MC5017501	400	30	OD50*175	0.75	131			220
L3	FLT□M1F-1MC5015001	400	40	OD50*150	0.87	130	207		
L4	FLT□M1F-1MC5029501	400	40	OD50*295	0.68	204	330		
L6	FLT□M1F-1MC5023001	200	60	OD50*230	0.72	166	Titanium alloy	284	
		201~400	45						
T2	FLT□M1F-1MF4821002	400	20	OD48*210	0.6	107		Titanium alloy	183
U1	FLT□M1F-1MF6139401	300	110	OD61.3*394	0.8	315			Titanium alloy
		301~400	90						
M9	FLT□M1F-1MB5020006	100	30	OD50*200	0.67	134	SUS316	224	
M8	FLT□M1F-1MB5017507	100	30	OD50*175	0.75	120		220	
M7	FLT□M1F-1MB5015016	100	40	OD50*150	0.85	130		207	
MC	FLTBM1F-2MB5009602	100	10	OD50*96	1.1 (Top mounting)	106		169	
MA	FLT□M1F-1MB5023004	100	60	OD50*230	0.72	166		280	
MB	FLT□M1F-1MB5029504	100	40	OD50*295	0.65	192		326	
T4	FLT□M1F-1MF4821001	100	20	OD48*210	0.58	107	Titanium alloy	189	

* Length of float: FLT□M1F-1□□50295 is extendable at unit of 50 mm (S.G drops 0.05 when length increases 50 mm).

* Float can be coated with PTFE.

* Measuring range may vary from float size changed for the top mounting type of by pass level indicator.

* The resolution of FG is 12.7mm, is restricted to use float temperature 100°C

FLOAT SPECIFICATIONS

~ Water Immersion location.

■ The Magnet location.

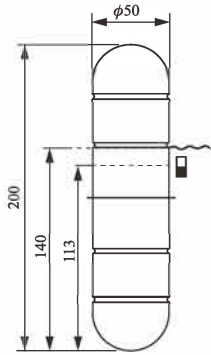

Code: M1/L1

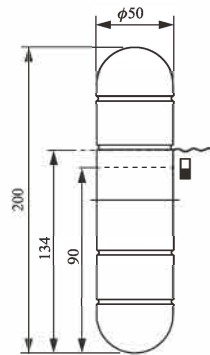

Code: M9

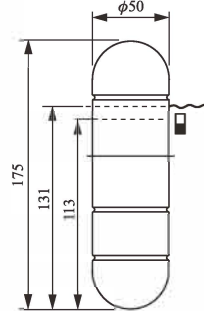

Code: M2/L2

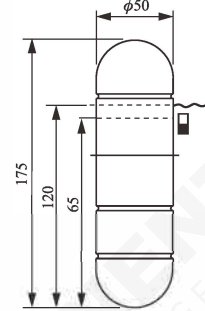

Code: M8

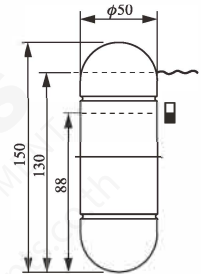

Code: M3/L3

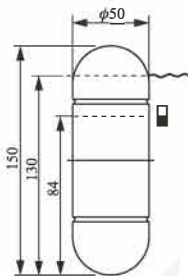

Code: M7

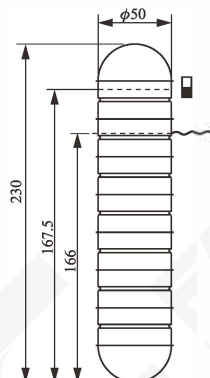

Code: M6/L6

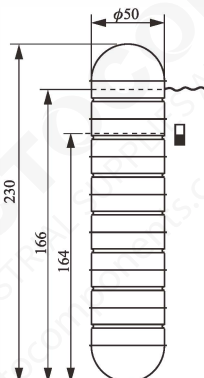

Code: MA

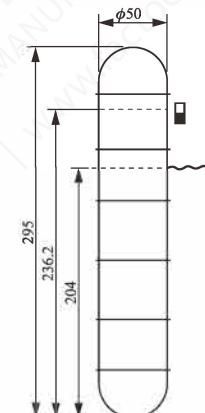

Code: M4/L4

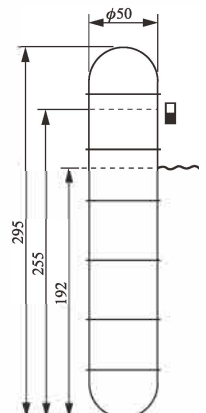

Code: MB

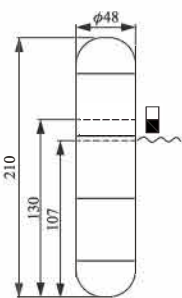

Code: T2

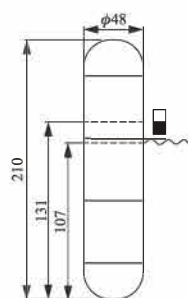

Code: 4

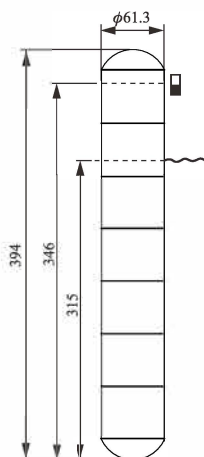

Code: U1

FLAG DISPLAY

Model No. EFB-0750

1. Housing material : SUS 304
2. Flag Material : Engineering plastic
3. Flag Color : Red / White; Green / White
4. Cover Material : Engineering plastics
5. Operation Temp. : -20~140°C
6. Standard Unit : 50mm

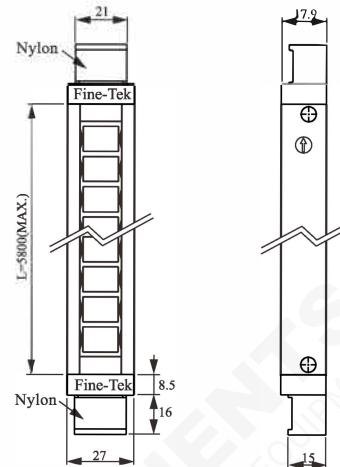

EFB-0750

Model No. EFB-0700

1. Housing material : SUS 304
2. Flag Material : Engineering plastic
3. Flag Color : Red / White; Green / White
4. Cover Material : Engineering plastics
5. Operation Temp. : -20~200°C
6. Standard Unit : 50mm

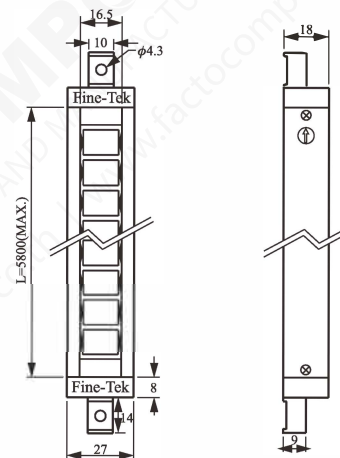

EFB-0700
EFB-0740

Model No. EFB-0740

1. Housing material : SUS 304
2. Flag Material : Ceramic
3. Flag Color : Red / White; Green / White
4. Cover Material : Glass
5. Operation Temp. : -20~400°C
6. Standard Unit : 50mm

Model No. EFB-0770

1. Housing material : SUS 304
2. Flag Material : SUS 304
3. Flag Color : Red / White; Green / White
4. Cover Material : Glass
5. Operation Temp. : -20~400°C
6. Standard Unit : 50mm

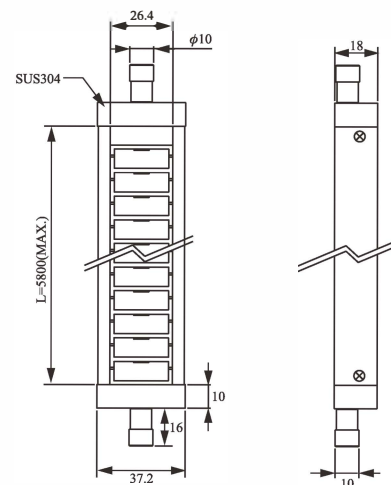

EFB-0770

RULER

Model No. EFA-2111 (unit: cm L Type)

Model No. EFA-2120 (unit: inch)

1. Dimension : 35(W)x1.5(T)xL
2. Material : SUS 304
3. Color : Black word
4. Operation Temp. : -20~400°C
5. Length : 5.8M (228")

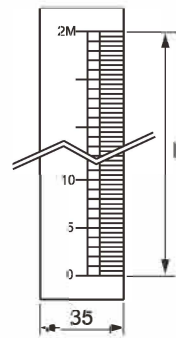

EFA-2111

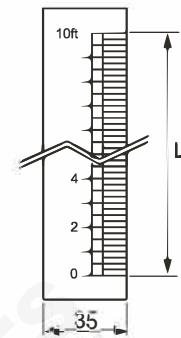

EFA-2120

Model No. EFA-2130-cm(unit: cm)

Model No. EFA-2130-in(unit: inch)

1. Dimension : 26(W)x3(T)xL
2. Material : Plastic
3. Color : Red word
4. Operation Temp. : -20~80°C
5. Length : 5.8M (228")

* Custom-made scale is available.

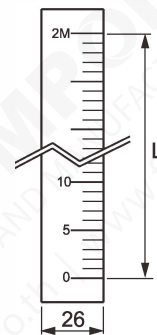

EFA-2130-cm

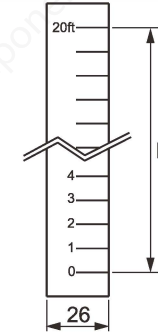

EFA-2140-in

MAGNETIC SWITCH

[ECONOMY TYPE]

Model No. EFB-1220/1230

1. Contact Element : Reed Switch
2. Switch Form : EFB-1220, SPDT Hold type
EFB-1230, SPDT Normal type
3. Contact Capacity : 1A /30W / 200Vdc /240Vac
4. Housing Material : Aluminum
5. Operation Temp. : -20~200°C
6. Protection : IP67
7. Cable Length : 1M (Silicon Cable)
8. Color code of wires: Black- COM; brown-NC; blue-NO
Yellow /green-GND

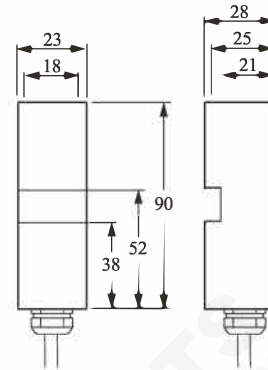

[STANDARD TYPE]

Model No. EFB-1250/1260

1. Contact Element : Reed switch
2. Switch Form : EFB-1250, SPDT Hold type
EFB-1260, SPDT Normal type
3. Contact Capacity : 1A /30W / 200Vdc /240Vac
4. Housing Material : Aluminum
5. Operation Temp. : -20~150°C(max. 250°C)
6. Protection : IP65

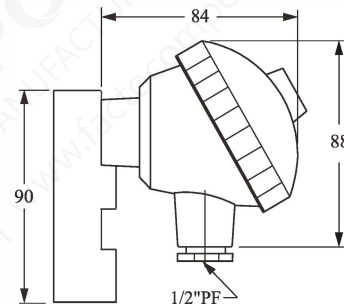

[ENCLOSURE EXPLOSION-PROOF TYPE]

Model No. EFB-1300/1310

1. Contact Element : Reed switch
2. Switch Form : EFB-1300, SPDT Hold type
EFB-1310, SPDT Normal type
3. Contact Rating : 1A /30W / 200Vdc /240Vac
4. Housing Material : Aluminum
5. Operation Temp. : -20~85°C (max. 250°C)
6. Protection : Ex d IIC T3~T6 Gb
7. Explosion-proof cable conduit is optional.

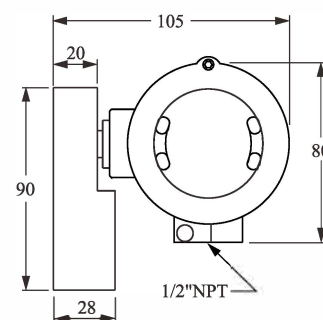

MAGNETIC SWITCH

[ADJUSTABLE TYPE]

Model No. EFB-14□□

- Contact Element : Reed Switch
- Switch Form : EFB-1400, SPST NO Hold type
EFB-1410, SPST NO Normal type
EFB-1420, SPDT Hold type
EFB-1430, SPDT Normal type
EFB-1440, SPST NO Hold type (side lead wire)
EFB-1450, SPST NO Hold type (LED display)
- Contact Rating : 1A /30W / 200Vdc /240Vac
- LED Power : 24 Vdc ± 20%(for EFB-1450)
- Housing Material : PP
- Operation Temp. : -20~140°C
- Protection : IP67
- Cable Length : 2M (PVC Cable)
- Contact wiring :
Red: COM, White: NO (EFB-1400/ 1410/ 1440 / 1450)
Black: COM, Red: NC, White: NO (EFB-1420 / 1430)

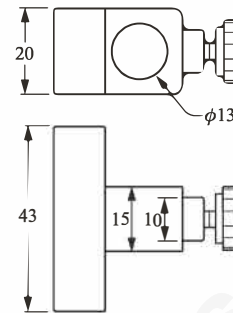

EFB-1450 Wiring

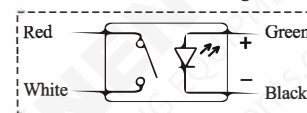

[HIGH CONTACT RATING TYPE]

Model No. EFB-1800

- Contact Element : Micro switch
- Switch Form : DPDT Hold type
- Contact Rating : 5A 250VAC ; 5A 30VDC
- Housing Material : Aluminum
- Process temp. : -20~400°C
- Protection : IP67
- Conduit : Rc 3/4
- Explosion-proof cable conduit (optional).

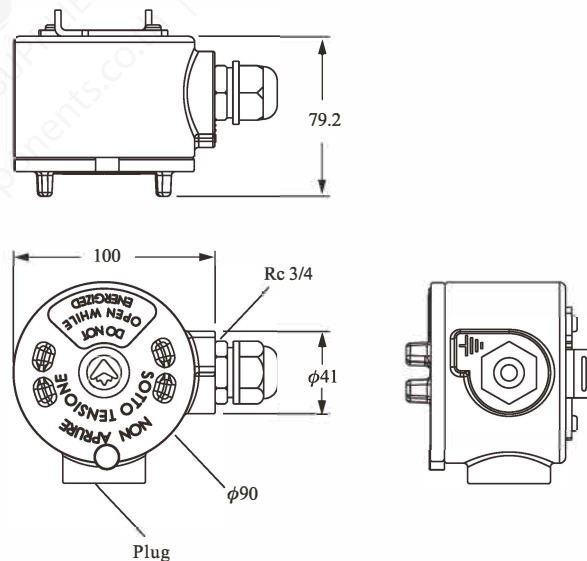

LEVEL TRANSDUCER

TYPE: FGX100□□-A6G000000□□□□□0000□00□□□□□

- Housing material : PC(IP65) 85(W)x80(H)x55(D)
- Tube : $\phi 14\text{mm}$ / $\phi 17.2$ (length over 3M)
SUS 304 or SUS 316
- Resolution : 6.35mm 、 12.7mm
- Output : 4~20mA two-wire
- Power : 12~36Vdc
- Measuring Range : 0.15~3M / 3~5.8M ($\phi 17.2$)
- Ambient Temp. : -10~80°C
- Accuracy : $\pm 0.1\%$

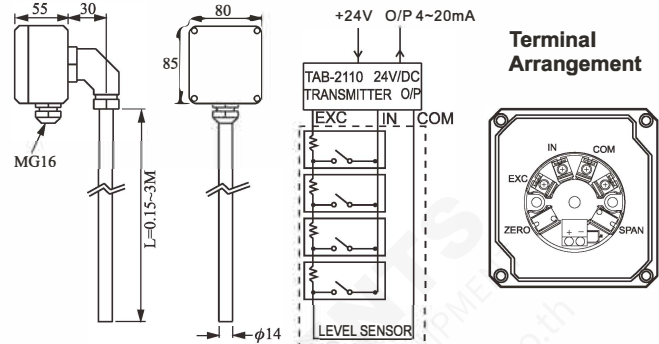

※The resolution of FG is 12.7mm, is restricted to use float temperature 100°C.

TYPE: FGX100□□-A6L000000□□□□□0000□00□□□□□

- Housing material : Aluminum EEx d IIC T6
- Tube : $\phi 14\text{mm}$ / $\phi 17.2$ (length over 3M)
SUS 304 or SUS 316
- Resolution : 6.35mm 、 12.7mm
- Output : 4~20mA two-wire
- Power : 12~36Vdc
- Measuring Range : 0.15~3M / 3~5.8M ($\phi 17.2$)
- Ambient Temp. : -10~80°C
- Accuracy : $\pm 0.1\%$
- Explosion-proof cable conduit is optional.

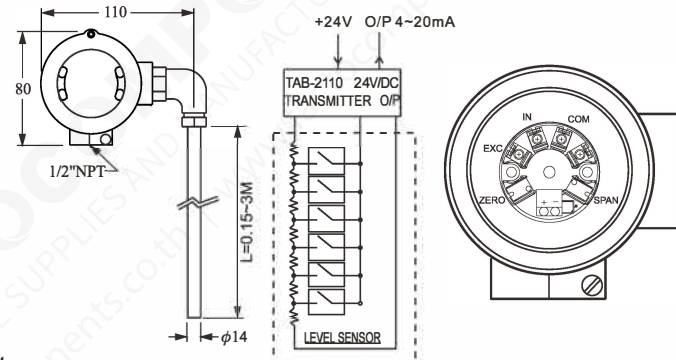

※The resolution of FG is 12.7mm, is restricted to use float temperature 100°C.

ORDER INFORMATION

FGX100 - 000000 0000 00

07 08 Certification

- 00: None
- 1C: ATEX-Ex d
- 2C: IECEX-db
- 5C: TS-Ex d
- 7C: NEPSI-Ex d
- 1D: ATEX-Ex tb
- B0: DNV.GL
- C0: ABS
- E0: BV
- F0: LR
- G0: CR

09 10 Sensor Type

- A1: Probe type
- A6: L Probe type

11 Terminal Housing

- G: PC (IP65)
- K: Aluminum (EEx d IIC T6)
- L: Aluminum (EEx d IIC T6)
- N: SUS304 or 316
- X: Aluminum (IP65)

18 Resolution

- C: 6.35mm
- E: 12.7mm

19 20 Probe material

- MA: SUS 304
- MB: SUS 316

21 22 Probe diameter

- 2B: $\phi 14.0\text{mm}$
- 2D: $\phi 17.2\text{mm}$ (More than 3 meters long)

27 Analog output

- B: 4~20 mA
- C: 20~4 mA

30 31 32 33 Length(C-C)

Code	Probe Length
0150~5800	150mm~5800mm

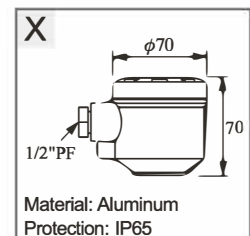
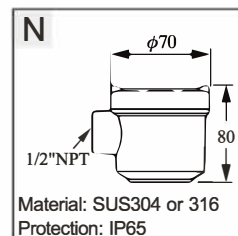
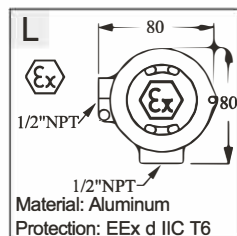
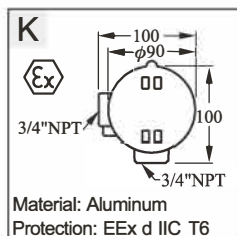
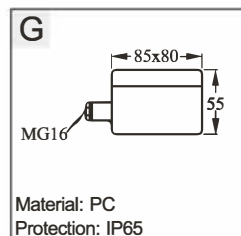

TRANSDUCER & TRANSDUCER WIRING DIAGRAMS

Model No.: TAB-2110 Transducer

Power Supply : 12~36Vdc
Output Current : Loop power 4~20mA
Load Resistance : $RL(\text{Max})=50(Vs-8)$
Operation Temperature : -40~80 °C
Ambient Humidity : 0~80 RH
Accuracy : $\pm 0.1\%(25^\circ\text{C})$
Temperature Effect : 0.01%F.S./°C
Adjustment Range : Span Adjustment 20% FS
 Zero Adjustment 5% FS

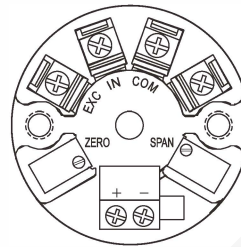

TRANSDUCER WIRING DIAGRAMS

► 2-wire level transducer (resistance output) connected with analog meter for level monitoring.

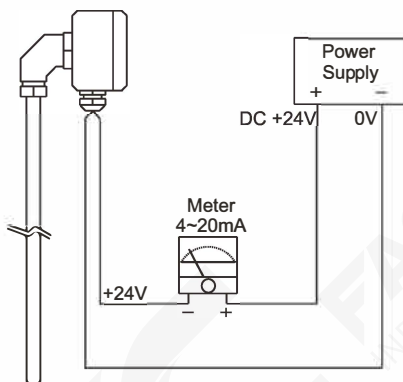

► 3-wire level transducer (4~20mA output) connected with 4~20mA analog meter for level monitoring.

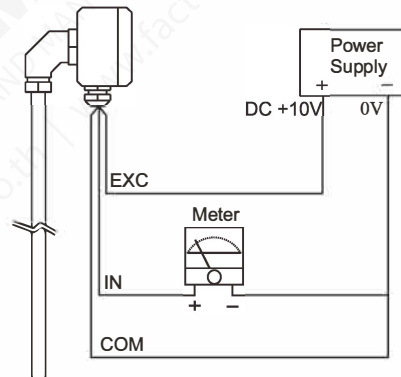

► 2-wire level transducer (4~20mA output) connected with digital meter (PB-Series) for level control.

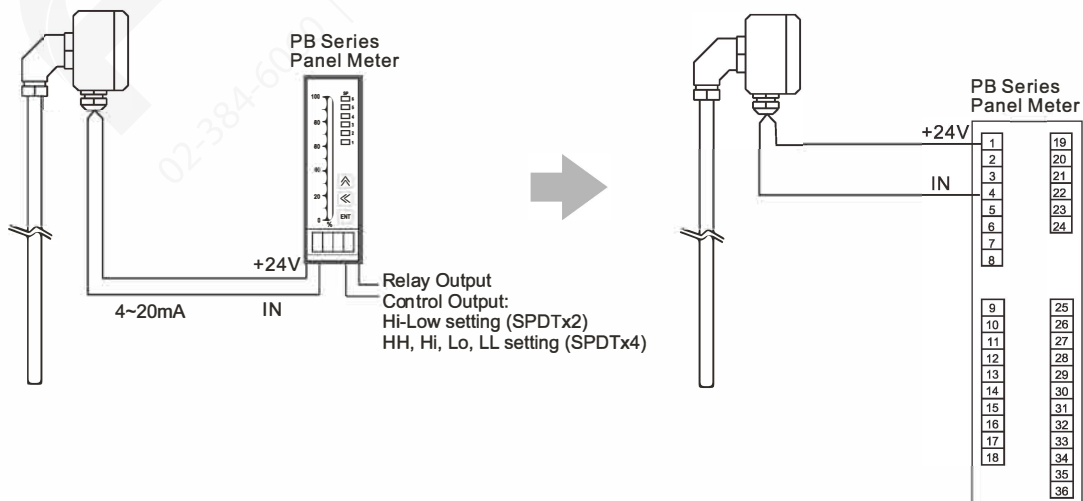

MAGNETOSTRICTIVE LEVEL TRANSMITTER / MODEL NUMBER / ORDER CODE COMPARISON TABLE

TYPE: EFX+EGX

1. Material : SUA304
2. Non-Linearity : $\pm 0.05\%$ F.S or $\pm 1.0\text{mm}$ (whichever is greater)
3. Repeatability : $\pm 0.01\%$ F.S或 $\pm 0.5\text{mm}$ (whichever is greater)
4. Operation Temp. : $-30^{\circ}\text{C}\sim 200^{\circ}\text{C}$
5. Output : $4\sim 20\text{mA}$
6. Communication : RS-485
7. Loop power : $+24\text{Vdc}\pm 10\%$
8. Protection : IP67

※Double flange type cannot be installed.

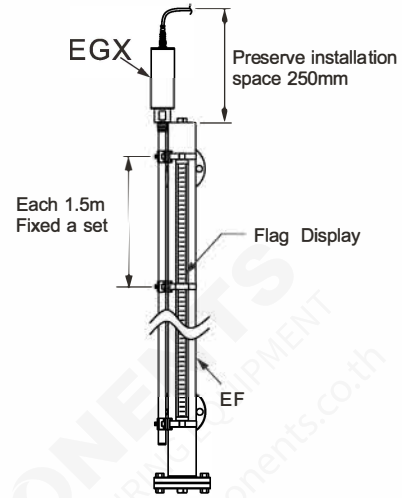

Model Number	Order Code
EG371 Ex-proof Standard Model	EGX1001B-A1
EG37A Ex-proof High Temp. Model	EGX1021B-A1
EG36 Display Model	EGX3001B-A1
EG36 Display High Temperature Model	EGX3021B-A1
EG36	EGX6□□□□-□□

※If the model number wasn't showed on above list, kindly refer to the catalogue of EG Magnetostriuctive Level Transmitter.

ORDER INFORMATION (EG36 ∙ EG37)

EGX ⁰⁴□ ⁰⁵□ ⁰⁶□ ⁰⁷□ ⁰⁸□ - A 1 0 0 0 0 0 0 ¹⁷□ ¹⁸□ ¹⁹□ ²⁰□ 0 0 0 0 ²⁵□ ²⁶□ ²⁷□ A 0 ³⁰□ ³¹□ ³²□ ³³□

04 Version

- 1: 132mm (EG37)
- 3: Display type (EG36)

05 06 Model

- 00: Standard
- 02: Hi-temperature

07 08 Certification

- 00: None
- 1B: ATEX-Ex ia
- 7B: NEPSI-Ex ia

17 18 Probe diameter

- 2A: φ12.7mm
- 2C: φ16.0mm

19 20 Probe material

- MA: SUS 304
- MB: SUS 316

25 Analog output

- 0: None
- A: 4~20mA
- B: 20~4mA

26 Digital output

- 0: None
- B: RS-485
- E: HART

※When RS-485 is applied, loop power only as power supply function, coding 25 has to be "0".

27 Housing

- A: Top conduit
- B: Side conduit

30 31 32 33 Length

Code	Probe Length
0150~2500	150mm~2500mm

※EFX By-pass level transmitter, Dual-flange, Blanket and Jacket type are not available for EG Magnetostrictive Level Transmitter.

※EG transmitter fastener code number: EGB-0500(EFXBMIP-MAF0000002)

ORDER INFORMATION (EG60)

EGX6 00 - A 1 0 0 0 0 0 0 0 0 0 0 0

⑤⑥ **Model**
00: Standard
02: Hi-temperature

⑰⑱ **Probe diameter**
2A: ϕ 12.7mm
2D: ϕ 17.2mm

⑲⑳ **Probe material**
MA: SUS 304
MB: SUS 316

㉕ **Input**
A: 2 wire
B: 4 wire

㉖ **Analog output**
0: None
A: 4~20mA
B: 20~4mA

㉗ **Digital output**
0: None
B: RS-485
E: HART

㉘ **Housing**
A: Top conduit
B: Side conduit

㉙ **Response time**
A: 16Hz
C: 250Hz

㉚ **Linearity**
3: 0.02% F.S V : 0.1mm ※ Only "7", "Y" can be selected for 2 wire type.
7: 0.05% F.S W : 0.2mm ※ All can be selected except "Y" for 4 wire type.
8: 0.1% F.S X : 0.5mm ※ Refer specification descriptions for more details of options.
 Y : 1mm

㉛㉜㉝㉞ **Length**

Code	Probe Length
0150~2500	150mm~2500mm

※EFX By-pass level transmitter, Dual-flange, Blanket and Jacket type are not available for EG Magnetostrictive Level Transmitter.

※EG transmitter fastener code number: EGB-0500(EFXBMIP-MAF0000002)

BALL VALVE

Metal Thread Type

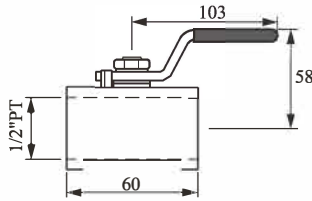

Plastic Thread Type

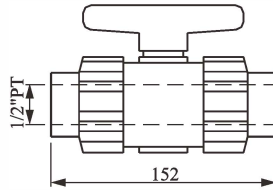

1	Body Material	SUS316	PP	PVDF
2	Working Temp.	150°C	80°C	120°C
3	Connection	1/2"PT	1/2"PT	
4	Working Pres.	20kg/cm ²	5kg/cm ²	

Metal Flange Type

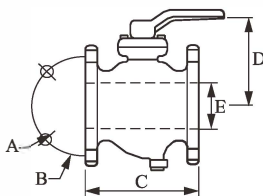

DIMENSIONS

SIZE	3/4"	1"
CODE	ACCORDING TO JIS 10K	
A, B	ACCORDING TO JIS 10K	
C	120	130
D	90	90
E	21.8	25

1	Body Material	SUS304
2	Working Temp.	150°C
3	Connection	3/4" JIS 10K 1" JIS 10K
4	Working Pres.	10kg/cm ²

Plastic Flange Type

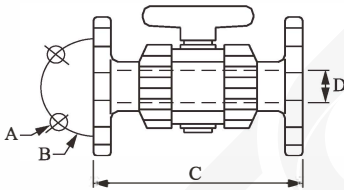

DIMENSIONS

SIZE	3/4"	1"
CODE	ACCORDING TO JIS 10K	
A, B	ACCORDING TO JIS 10K	
C	172	187
D	18	23

1	Body Material	PP	PVDF
2	Working Temp.	80°C	120°C
3	Connection	3/4" JIS 10K 1" JIS 10K	
4	Working Pres.	5kg/cm ²	

Bellows Sealed Valve

Thread Type

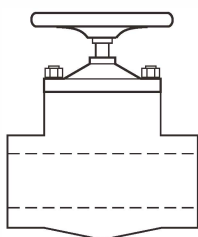

Flange Type

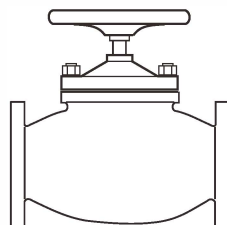

Project	Thread	Flang
1	Body Material	SUS316
2	Working Temp.	350°C
3	Connection	3/4"PT 1"PT
4	Working Pres.	25kg/cm ²
		DN15 PN16 DN20 PN16

ORDER INFORMATION

MT1 1 1-

06 Model

- B: Ball Valve
- 4: Bellows Sealed Valve

07 Connection type

- 1: Thread Type
- 4: Flange Type

Connection

08 09

- A5: 1/2"
- A7: 3/4"
- A8: 1"
- A9: 1-1/4"
- B1: 1-1/2"
- D6: DN15
- D7: DN20
- D8: DN25
- D9: DN32
- E1: DN40

10 11

- Flange
- 40: 5kg/cm²
- 42: 10kg/cm²
- 48: 150Lbs
- 49: 300Lbs
- 57: PN 10
- 58: PN 16

- Thread
- 01: PT male
- 02: PT Female
- 03: PF male
- 04: PF Female
- 05: BSP Female
- 06: BSP male
- 07: NPT male
- 08: NPT Female

12 13 Connection material

- 18: PP
- 24: PVDF
- MA: SUS304
- MB: SUS316
- MC: SUS316L
- ME: Carbon steel

OPTIONS

As shown below the optional accessories can be installed on to a By-Pass Level Indicator to monitor and control the level of the liquid.

A. Flag Indicator

- 1) Economy Type : EFB-0750 series
- 2) Standard Type : EFB-0700 series
- 3) High Temp. Type : EFB-0740 series

C. Magnetic Switch (see page 15)

- 1) Economy Type : EFB-1220 series
- 2) Standard Type : EFB-1250 series
- 3) Explosion-proof Type : EFB-1300 series
- 4) Adjustable Type : EFB-1400 series

B. Ruler

- 1) Stainless ruler (metric) : EFA-2110/2111(L Type)
- 2) Stainless ruler (imperial): EFA-2120
- 3) Plastic ruler (metric) : EFA-2130
- 4) Plastic ruler (imperial) : EFA-2140

D. Level Transducer

- 1) 3-wire standard
- 2) 2-wire standard
- 3) 3-wire explosion proof
- 4) 2-wire explosion proof
- 5) 2-wire reversible

E. Magnetostrictive Level Sensor

- 1) 2-Wire

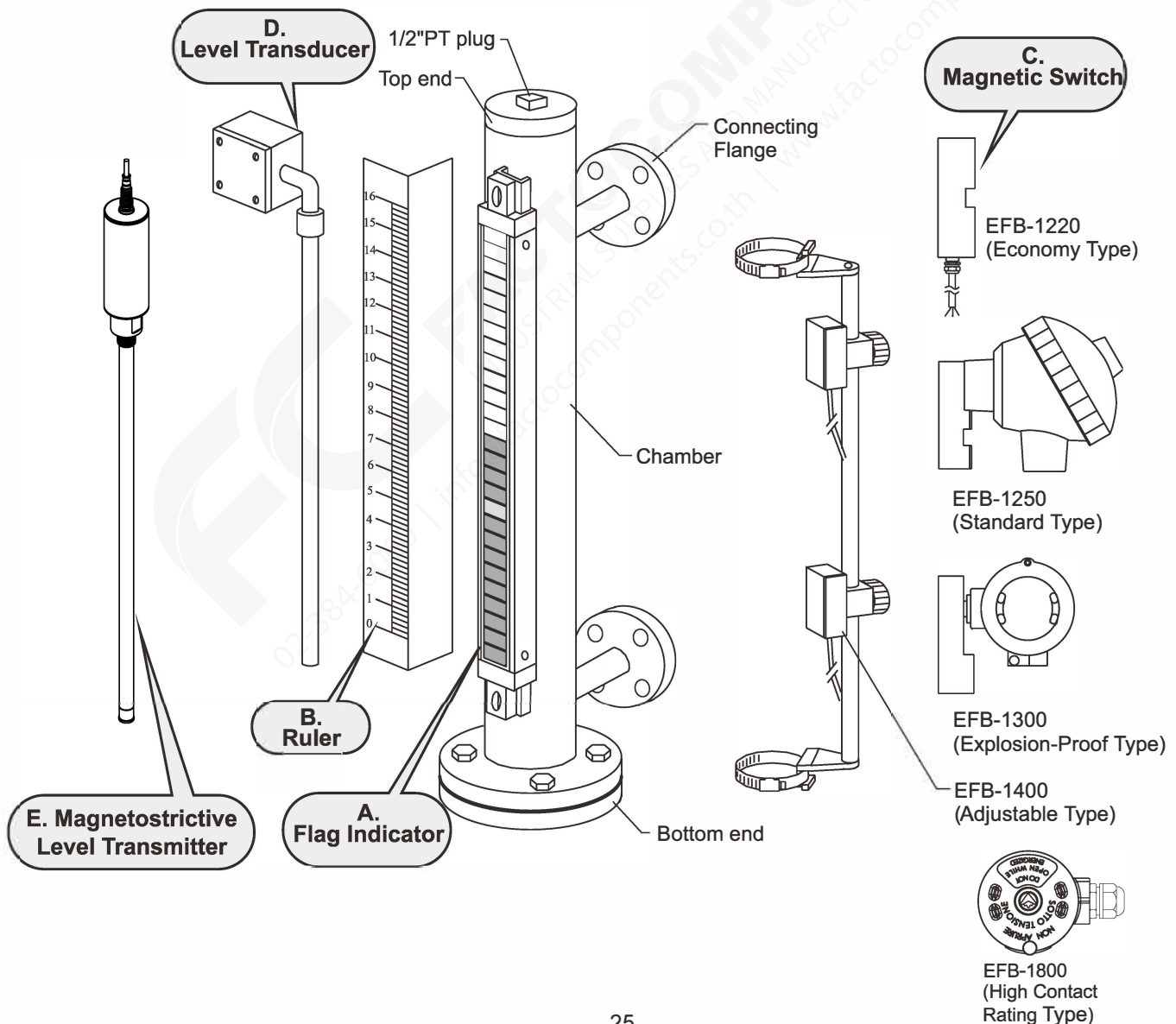

TYPICAL ASSEMBLY

1. (Fig.1) By-pass Level indicator with the standard magnetic switches (Aluminum Alloy) and liquid level transmitter. With the housing protection IP65, it is suitable for outdoor or moist environment.
2. (Fig.2) By-pass Level Indicator with explosion-proof magnetic switches. With its housing protection Ex d IIC T3~T6 Gb, it is applicable for hazardous environments .
3. (Fig.3) By-pass Level Indicator with adjustable magnetic switches and SUS304 ruler. It can be assembled with upward /downward movable multiple magnetic switches on a riding rod.
4. (Fig.4) By-pass Level Indicator with high contact rating (5A 250Vac ; 5A 30Vdc) magnetic switch.

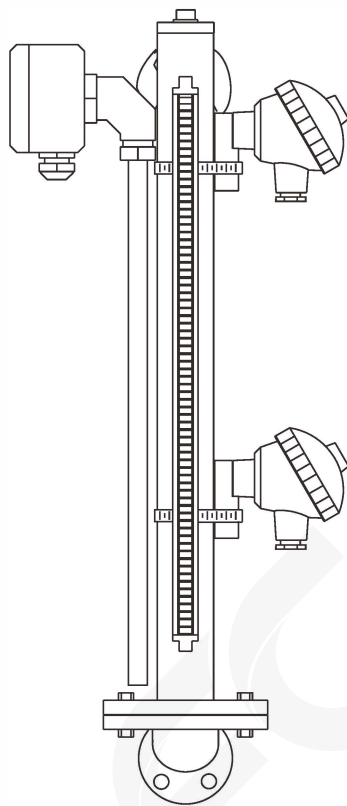

fig. 1

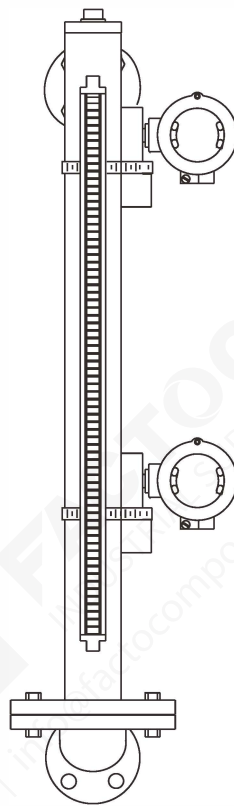

fig. 2

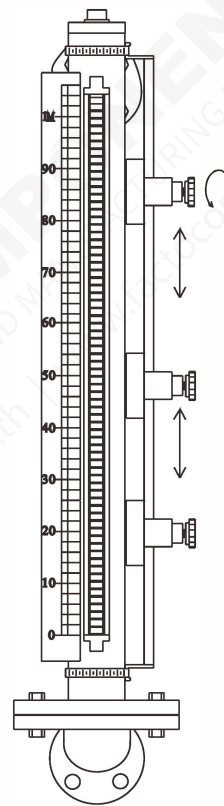

fig. 3

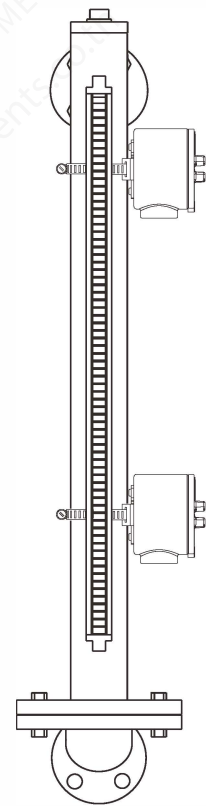

fig. 4

CAUTIONS FOR INSTALLATION

1. The adjustable magnetic switch (EFB-14□□ series) is placed on a riding rod, then fasten the riding rod to the chamber with two hose clamps. (see page 24 - fig.3)
2. The magnetic switch (EFB-12□□ ,EFB-13□□ & EFB-1800) is to be fastened on the chamber with a hose clamp. (see fig.5 and page 24 - fig.1, fig.2, fig.3, fig.4) Positioning orientation of magnetic switches.
3. Because the magnetic switch is a sensitive component, thus any extreme shock to the switch will cause malfunction.
4. Make sure there is no external magnetic field or source within 10 centimeters of the switch to avoid magnetic interference.
5. Make sure the wire of the magnetic switch is pointing downward.
6. Do not contact any high temperature material with unit's cables while wiring.
7. When using magnetic switch to control inductive or capacitive load, a RC protective circuit should be used to ensure long life of the switch contact.
8. The magnetic switch must be located near the flag display and the surface of it is as close to the outer chamber wall as possible.(fig. 6)
9. Before actuating, be sure all wirings are done correctly.
10. See fig.5 for the installation direction of mounting holes
11. C-C length (plastic type >1.5m; metal type >3.5m), fix support is recommended. The distance between fix support/ flange shall be within 1 m (plastic type); 2.5 m (metal type). It depends on the application to have different fix support, FineTek provide customized service as fig. 8 showed.
12. Dust-proof plug on the flange should be removed before installation, as fig. 8 showed.

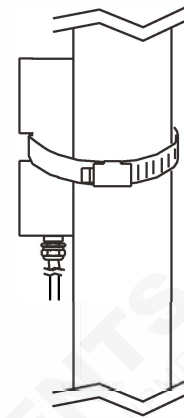

fig. 5

Position Orientation Of Magnetic Switches

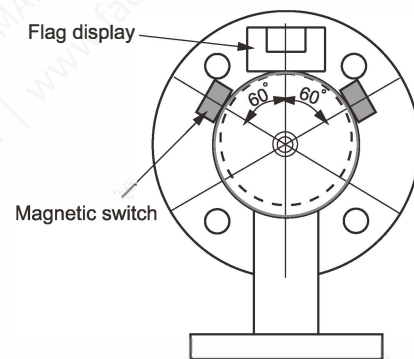

fig. 6

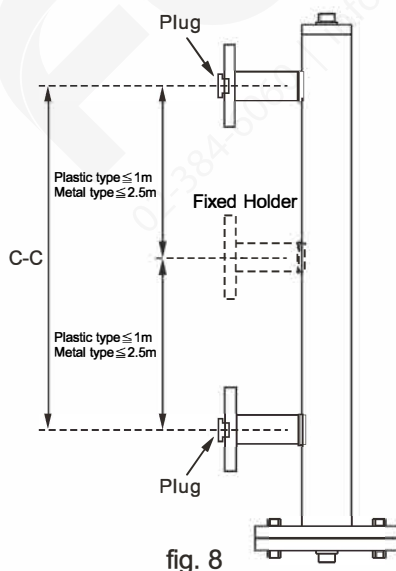

fig. 8

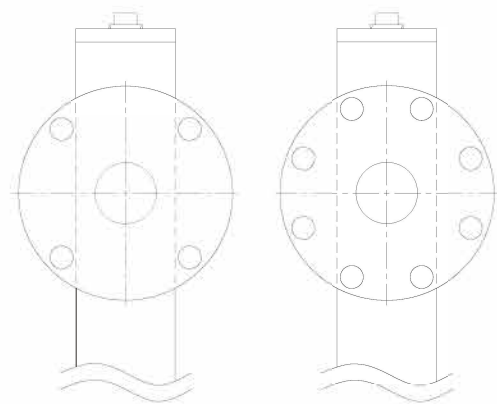

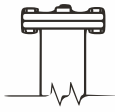



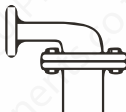

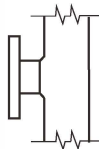

fig. 7

ORDER INFORMATION



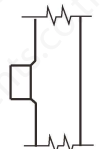
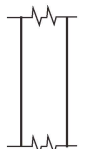
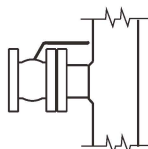

Top End Type

A Cap	B Flat top +Plug	C Dual flange +Plug	D Flat top +Top mounting flange
			
E Dual flange +Top mounting flange	F Flat top +Control valve	G Dual flange +Control valve	N Dual flange +Angle pipe
			

Connection

1 Flange	2 Screw (bolt type)	3 Screw (nut type)	4 Slip pipe	5 N/A	7 Control valve
					

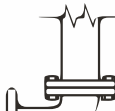
Bottom End Type

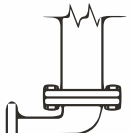
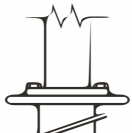
C Dual flange+Plug	E Dual flange +Bottom mounting flange	M Dual flange +Angle pipe+Plug	G Dual flange +Control valve
			
N Dual flange +Angle pipe	R Dual flange +Bottom mounting pipe		
			

ORDER INFORMATION

EFX1 ⁰⁵ ⁰⁶ ⁰⁷ ⁰⁸ - ⁰⁹ ¹⁰ ¹¹ ¹² ¹³ ³² ³³ ³⁴

05 06 Model

- 00: Standard type (< 140°C)
- 01: Plastic standard type
- 02: High temperature type (200°C)
- 05: High Pressure Type (31~60kg/cm²)
- 06: High Pressure Type-1 (61~100kg/cm²)
- 08: High temperature type-1 (350°C)
- A1: Antiseptic Type
- A2: Blanket Type
- A3: Jacket Type
- A4: Heating Type
- 25: High temperature & Pressure(350°C, 31~60kg/cm²)

07 08 Certificate

- | | |
|------------|--------|
| 00: None | E0: BV |
| B0: DNV.GL | F0: LR |
| C0: ABS | G0: CR |

09 Top end model

- | | |
|---------------------------------|------------------------------------|
| A: Cap | E: Dual flange+Top mounting flange |
| B: Flat top+plug | F: Flat top+Control valve |
| C: Dual flange+plug | G: Dual flange+Control valve |
| D: Flat top+Top mounting flange | N: Dual flange+Angle pipe |

10 Connection(C-C)

- 1: Flange
- 2: Screw (bolt type)
- 3: Screw (nut type)
- 4: Slip pipe
- 5: N/A
- 6: Flange flexible
- 7: Control valve

11 Bottom end model

- C: Dual flange+plug
- E: Dual flange+Bottom mounting flange
- G: Dual flange+Control valve
- M: Dual flange+Angle pipe+Plug
- N: Dual flange+Angle pipe
- R: Dual flange+Bottom mounting pipe

(Next page)

