



ALCM-DT & ALCM-ST

Coriolis Mass Flowmeter

Model ALCM Series



GENERAL

SMARTMEASUREMENT's ALCM-DT and ALCM-ST flowmeters employ unique tube arrangements for applications requiring very low mass flow measurement. The delta-shaped measuring tubes are used for 1/8"~ 1" (3-25mm) line sizes while a straight tube arrangement is employed for 2"~3" (50~80mm) lines. The delta, or triangular tube geometry of the ALCM-DT allows it to measure mass flows as little as 5 kg/hr. In applications where lower pressure drops are a critical criteria, the ALCM-ST, is nearly a straight tube with a slight bend to minimize the fluid shear stress in the flow tube. This allows the ALCM-ST to obtain significantly lower pressure drops versus similarly sized Coriolis meters.

All Coriolis flow meters in the ALCM family employ an easy-to-read color OLED display that can be configured to display either mass or volumetric flow rates in a variety of user-selectable engineering units as well as density, temperature, and totalized flows. Our ALCM family of Coriolis mass flowmeters provide a highly accurate, compact instrument that can measure flow, density, and temperature in a single package that has lower cost, lower pressure differential and a more compact design versus competitive Coriolis-technologies.



ALCM-DT



ALCM-ST

FEATURES

- Suitable for aggressive and contaminated media
- Measurement of mass flow, density, temperature and volume flow
- Very low pressure drop with ALCMST in 50 and 80mm sizes
- Excellent low flows performance using the ALCMDT
- Operation up to+ 662 °F (350 °C)
- Individual 8-point-calibration including report
- EX protection (optional) -UL/CUL/CSA

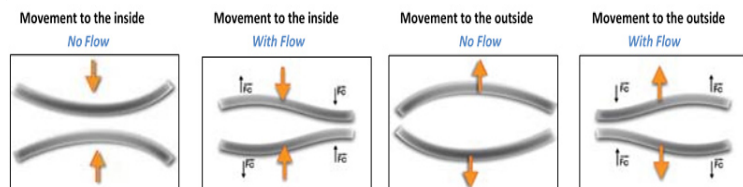

SPECIFICATIONS

- | | | | |
|--------------------------|--|-------------------------|---|
| • Flow Range: | 12 ~ 900,000 kg/hr.
(26 ~ 2,000,000Lb/hr.) | • Process Temperature: | -58~392 °F (-50~200 °C) -std |
| • Line Sizes: | 3~200 mm (1/8 ~ 8") | • Ambient Temperature: | -5~312 °F (-20~55 °C) |
| • Process Connections: | Flanged (ANSI, DIN, Tri-Clamp®) | • Max Working Pressure: | 360 psig (2.5MPA) std,
930 psig optional |
| • Tube geometry: | Delta-Tube or Straight Tube | • Measuring Tube Mat'l: | SS per DIN1.4571 (AISI 316Ti)
standard |
| • Accuracy: | ±0.5% of reading (std),
0.2% or 0.1% (opt) | • Housing Material: | SS #304 |
| • Repeatability: | ±0.075% of reading | • Power Supply: | 24 VDC, ± 20%; 86~260VAC |
| • Frequency: | 10-2000 Hz | • Power Consumption | Less than 6W |
| • Display: | LCD | • Outputs: | 4-20 mA, 0-10 kHz pulse, RS485 |
| Eng. Units (mass): | kg, lb., and ton | • Density Meas. Range: | 12.5-125lb/ft ³ (0.2~2.0 g/cc) |
| Eng. Units (Temp): | °C, °F | • Density Accuracy: | ±0.06 b/ft ³ (0.001 g/cc) |
| Eng. Units: (Vol.) | m ³ , Liter, US Gallon, Imperial
Gallon, Million Gallon, | • Temperature Accuracy: | up to ±1°F (°C) |
| • Zero Stability: | 0.1% full-scale | | |
| • Zero Drift (%FS / °C): | 0.005 | | |

METER SIZE (MM)	FLOW RANGE LB/HR. (KG./HR.) (0.2% & 0.5% ACCURACY)	FLOW RANGE LB/HR. (KG./HR.) ACCURACY 0.1%	STABILITY OF ZERO POINT LB/HR. (KG./HR.)
03 ALCM-DT	11~220 (5~100)	22~220 (10~100)	0.004 (0.002)
08 ALCM-DT	388~1764 (70~800)	220~1764 (100~800)	0.015 (0.007)
10 ALCM-DT	220~2204 (100~1,000)	330~2204 (150~1000)	0.044 (0.02)
15 ALCM-DT	440~6614 (200~3,000)	551~6614 (250~3000)	0.154 (0.07)
25 ALCM-DT	661~17367 (300~8,000)	1213~17367 (550~8000)	0.771 (0.35)
50 ALCM-ST	5512~110231 (2500~50,000)	11023~110231 (5000~50000)	3.30 (1.5)
80 ALCM-ST	11023~220462 (5,000~100,000)	17637~ 264555 (8000~120000)	7.75 (3.5)

Accuracy

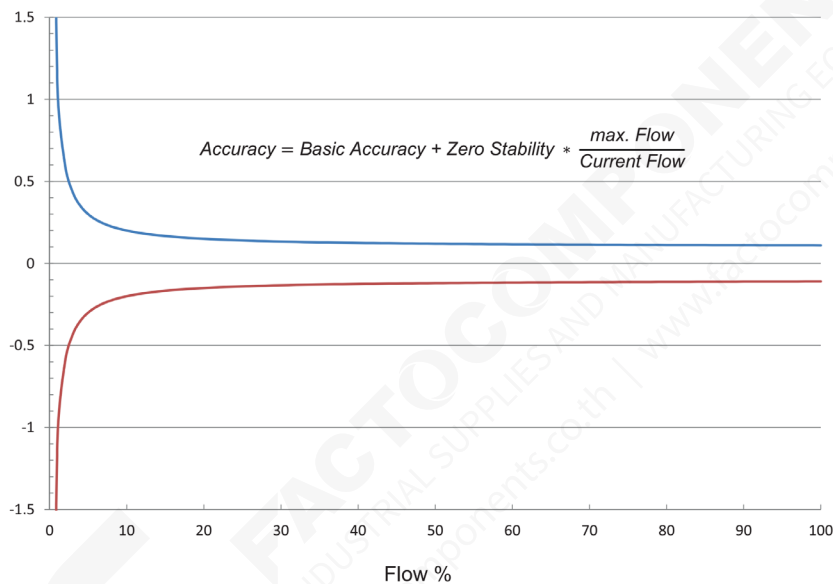

This diagram shows typical values. Individual values may be taken from the calibration records supplied with each meter.

Repeatability

ACCURACY	0.1%	0.20%	0.50%
REPEATABILITY	±0.05%	±0.1%	±0.25%

Density Measuring

DENSITY RANGE	12.5-125 Lb./ft ³ (0.2~2.0 g/cc)
BASIC ERROR	±0.06 b/ft ³ (0.001 g/cc) Affected by the transducer
REPEATABILITY	±0.06 b/ft ³ (0.001g/cm ³)

DIMENSIONS

TRANSDUCER

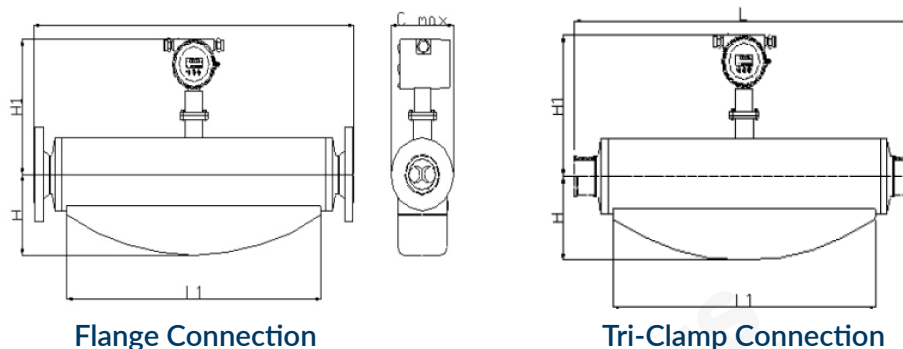

Outline dimensions ALCM-ST

-All dimensions in units of inches (mm)-

NOMINAL LINE SIZE	L 1.6-40 BAR	L 64 BAR	L1	H	H1	C-MAX	SHIPPING WEIGHTS LB (KG)
2" (50)	31.5 (800)	32.8 (834)	24.9 (620)	7.9 (200)	12.6 (320)	8.1 (205)	67 (30)
3" (80)	36.8 (935)	38.3 (973)	28.7 (730)	7.9 (200)	12.6 (320)	16.4 (416)	132 (60)

NOMINAL LINE SIZE	L 1.6-40 BAR	L 64 BAR	L1	H	H1	C-MAX	SHIPPING WEIGHTS LB (KG)
2" (50)	31.5 (800)	32.8 (834)	17.7 (450)	7.9 (200)	12.4 (315)	8.1 (205)	67 (30)
3" (80)	36.8 (935)	38.3 (973)	25.4 (645)	7.9 (200)	13.2 (335)	16.4 (416)	132 (60)

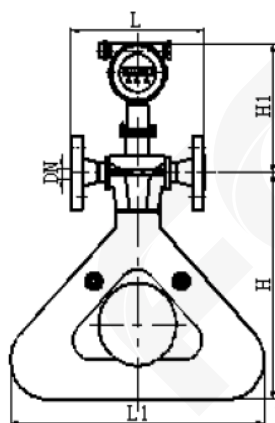

Pressure Drop Versus Velocity ALCMDT & ALCMST

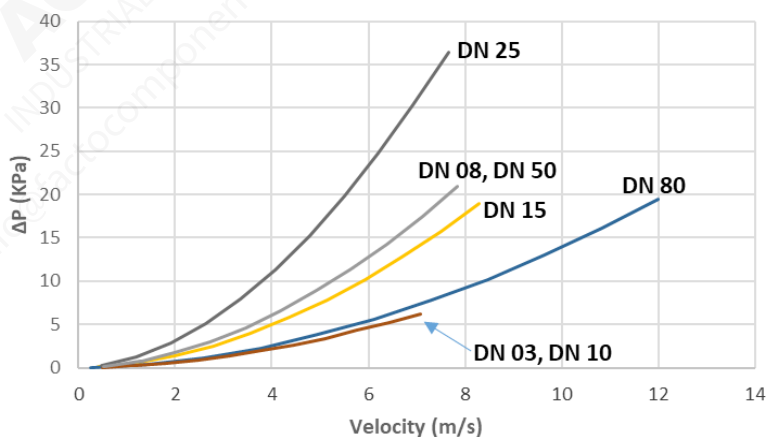

The velocity is based on water at standard conditions

Outline dimensions ALCM-DT

-All dimensions in units of inches (mm)-

NOMINAL LINE SIZE	L 1.6-40 BAR	L 64 BAR	L1	H	H1	C-MAX	SHIPPING WEIGHTS LB (KG)
1/16" (3)	5.9 (150)	6.7 (170)	13.4 (350)	11.4 (290)	10.2 (260)	3.7 (95)	24 (11)
1/8" (8)	5.9 (150)	6.7 (170)	13.4 (350)	11.4 (290)	10.2 (260)	3.7 (95)	24 (11)
3/16" (10)	5.9 (150)	6.7 (170)	13.4 (350)	11.4 (290)	10.2 (260)	3.7 (95)	24 (11)
1/2" (15)	7.1 (180)	7.6 (194)	13.4 (350)	11.8 (300)	10.2 (260)	3.7 (95)	24 (11)
1" (25)	7.9 (200)	9.8 (248)	17.7 (450)	16.5 (420)	11.0 (280)	4.5 (115)	33 (15)

TYPE OF FLUID	Please provide the name of your fluid, including operating density and viscosity
FULL-SCALE FLOW RATE	Please provide the max and min flow rate, normal flow rate also
LINE SIZE	Please provide the line size and connection
PROCESS PRESSURE & TEMPERATURE	We will calibrate your flow meter as close to your operating conditions as possible
PRESSURE DROP	Please indicate the maximum allowable pressure drop
TYPE OF ELECTRONICS	Please specify output and installation type (wall mount, panel mount, etc.)
POWER REQUIREMENTS	Please specify AC or DC power supply

ALCM-DT OR ALCM-ST SERIES

EXAMPLE 1: ALCM-DT-025-F-5-1-N-CBS-NX-DC-NN

ALCM-DT OR ALCM-ST	**	**	**	**	**	**	**	**	**	**	DESCRIPTION
DN3 (5-100 kg/hr) DT ONLY	003										Nominal Line Size
DN8 (70-800 kg/hr) DT ONLY	008										
DN10 (100-1,000 kg/hr) DT ONLY	010										
DN15 (200-3,000 kg/hr) DT ONLY	015										
DN25 (300-8,000 kg/hr) DT ONLY	025										
DN50 (2,500-50,000 kg/hr) ST ONLY	050										
DN80 (15,000-150,000 kg/hr) ST ONLY	080										
ANSI 150 #		F									Process Connections
ANSI 300# flange		F3									
Other connection		O									
0.1% -			1								Accuracy
0.2% -			2								
0.5% - standard			5								
232 psi (1.6 MPa) - standard				1							Working Pressure
362 psi (2.5 MPa)				2							
580 psi (4.0 MPa)				3							
Up to 176°F (80°C) - standard					N						Working Temperature
Up to 302°F (150°C)					M						
Up to 482°F (250°C)					H						
CB03 Compact Version -local display, 4-20mA, RS485						CBS					Transmitter
CB03 Compact Version -local display, 4-20mA, RS485 and HART						CBH					
CB03 Remote Version - display, 4-20mA, RS485						RBS					
CB03 Remote Version - display, 4-20mA, RS485 and HART						RBH					
TRO Remote Version - surface touch control, display, 4-20mA, RS485						TRO					
Other transmitter						RE					
Non-Explosion							NX				Approval
Ex protection EEx d Explosion proof UL/CUL/CSA							XD				
24 V _{DC}								DC			Power Supply
85-260 V _{AC} , 50/60 Hz								AC			
Standard - with 316L measuring tube									NN		Options
Signal cable for remote type - extra length									CABL		
Heat jacket									HJ		

