

Pressure transmitter P3000 series Datasheet



FACTO COMPONENTS CO., LTD. | บริษัท แฟ็คโต คอมโพเนนส์ จำกัด

845/3-4 ชั้น 3 ถ.เทพารักษ์ ต.เทพารักษ์ อ.เมือง จ.สมุทรปราการ 10270

TEL. 02-384-6060, 086-369-5872 LINE OA : @factocomps Website : www.factocomponents.co.th Email : info@factocomponents.co.th

The high performance Gauge / Absolute pressure transmitter MIK-P600 is suitable to measure liquid, gas, or steam flow as well as liquid level, density and pressure. It outputs a 4~20 ma DC signal corresponding to the measured pressure. Its highly accurate and stable sensor can also measure the static pressure which can be shown on the integral indicator or remotely monitored via HART communications. Other key features include quick response, remote set-up using communications, self-diagnostics and optional status output for pressure high/low alarm.

FUNCTIONAL SPECIFICATIONS

High accuracy Gauge pressure :

Span/ Range Limits		kPa	psi	bar	Kgf/cm ²
C/S	Span	2~40	0.29~5.8	0.02~0.4	0.02~0.4
	Range limits	-40~40	-5.8~5.8	-0.4~0.4	-0.4~0.4
D	Span	2.5~250	0.3625~36.25	0.025~2.5	0.025~2.5
	Range limits	-100~250	-14.5~36.25	-1~2.5	-1~2.5
F	Span	30~3000	4.35~435	0.3~30	0.3~30
	Range limits	-100~3000	-14.5~435	-1~30	-1~30
G	Span	0.1~10MPa	14.5~1450	1~100	1~100
	Range limits	-0.1~10MPa	-14.5~1450	-1~100	-1~100
H	Span	0.21~10MPa	30.45~3045	2.1~210	2.1~210
	Range limits	-0.1~21MPa	-14.5~8000	-1~210	-1~210
I	Span	0.4~40MPa	58~5800	4~400	4~400
	Range limits	-0.1~40MPa	-14.5~5800	-1~400	-1~400

High accuracy Absolute pressure :

M	Span	2.5~250	0.3625~36.25	0.025~2.5	0.025~2.5
	Range limits	0~250	0~36.25	0~2.5	0~2.5
O	Span	30~3000	-4.35~435	0.3~30	0.3~30
	Range limits	0~3000	0~435	0~30	0~30

PERFORMANCE SPECIFICATIONS

Reference Accuracy of Calibrated Span:

(includes terminal-based linearity, hysteresis, and repeatability)

±0.075%, ±0.1%

If TD>10(TD=URL/SPAN), ±(0.005×TD)%

Ambient Temperature Effects

-20°C~65°C: ±(0.075×TD+0.025)%×Span

Every 10°C is ±0.04% ×Span (TD=1)

-40°C~-20°C & 65°C~85°C:±(0.1×TD+0.025)%×Span

Pressure transmitter



Over pressure Effects

$\pm 0.05\% \times \text{Span}$

Stability

$\pm 0.1\% \times \text{Span} / 3 \text{ years}$

Power Supply Effects

$\pm 0.001\% / 10\text{V}$ (12~36V DC)

Zero Adjustment Limits

Zero can be fully elevated or suppressed, within the lower and upper range limits of the capsule.

External Zero Adjustment

External zero is continuously adjustable with 0.01% incremental resolution of span. Re-range can be done locally using the range setting switch.

Mounting Position Effects

Rotation in diaphragm plane has no effect. Tilting up to 90° will cause Span C zero shift up to 0.25 kPa, others up to 0.15 kPa, which can be corrected by the zero adjustment.

Output

Two wire 4~20 mA DC output with digital communications, linear or square root programmable. HART FSK protocol are superimposed on the 4~20 mA DC signal. Output range: 3.9 mA to 20.5 mA.

Failure Alarm (the mode can be selected)

Low Mode (min): 3.7 mA

High Mode (max): 21 mA

No Mode (hold): Keep the effective value before the fault. Note: The standard setting of failure alarm is High Mode.

Response Time

The amplifier damping constant is 0.1 sec; The sensor damping constant is 0.1~1.6 sec, it depends on the range and range compression ratio. Amplifier damping time constant is adjustable from 0.1 to 60 sec by software and added to response time.

UpTime <15s

Ambient Temperature Limits

-40 to 85°C / -20 to 65°C with LCD display or fluorine rubber sealing

Storage and Transportation Temperature Limits

-50 to 85°C / -40 to 85°C with LCD display

Pressure transmitter



Pressure Limits

Vacuum to maximum working pressure.

Overload Pressure Limit

Span	40kPa		250kPa(D/M)	3MPa(F/O)
	(C)	(S)		
maximum overload pressure	1MPa	7MPa	4MPa	15MPa
Span	10MPa(G)		21MPa(H)	
maximum overload pressure	20MPa		50MPa	50MPa

Electromagnetic Compatibility (EMC)

Look the EMC Performance Table

Explosion Protected Type Need confirmation

NEPSI / ATXE: Ex dIIC T6

NEPSI / ATXE: Ex iaIIC T4

Amb. Temp.: -40~65°C

INSTALL

Supply & Load Requirements

24VDC supply, $R \leq (U_s - 12V) / I_{max}$ k Ω , $I_{max} = 23$ mA. Maximum voltage limited: 36VDC, Minimum voltage limited: 8.3VDC, 11.3VDC (with LCD display) 230 Ω to 600 Ω for digital communication

Electrical Connection

The electrical connection is made via cable entry M20x1.5. The screw terminals are suitable for wire cross-sections 0.5~2.5mm²

Process Connection

Standard process connection:

NPT1/2 female thread;

Can be changed to NPT1/2, G1/2, M20*1.5 male thread and KF16 Vacuum interface

PHYSICAL SPECIFICATIONS

Wetted Parts Materials

Isolating Diaphragm: 316L stainless steel / Hastelloy C

Process Connector: 316 stainless steel

Fill fluid: Silicone oil/Fluorinated oil

Amplifier Housing: Aluminum with epoxy resin coat

Process Connector Gasket: Perbunan (NBR)

Name plate and tag: 304 stainless steel

Weight: 1.6 kg

Degrees of Protection: IP67

EMC Performance Table

Items	Test items	Test conditions	Performance Level
1	Radiated interference (Housing)	30MHz~1000MHz	OK
2	Conducted interference (DC power port)	0.15MHz~30MHz	OK
3	Electrostatic Discharge (ESD) Immunity	4kV(Line) 8kV(Air)	B
4	RF electromagnetic field immunity	10V/m (80MHz~1GHz)	A
5	Frequency magnetic field immunity	30A/m	A
6	Electrical Fast Transient Burst Immunity	2kV(5/50ns,5kHz)	B
7	Surge Immunity	0.5kV(line to line) 1kV(line to ground) (1.2us/50us)	B
8	Conducted interference immunity induced by RF field	3V (150KHz~80MHz)	A

Note:

(1) Performance level A description: The technical specifications within the limits of normal performance.

(2) Performance level B description: Temporary reduction or loss of functionality or performance, it can restore itself. The actual operating conditions, storage, and data will not be changed.

Pressure transmitter



DIMENSIONS

Unit : mm

1 Horizontal Impulse Piping Type(side face)

2 Horizontal Impulse Piping Type(front side)

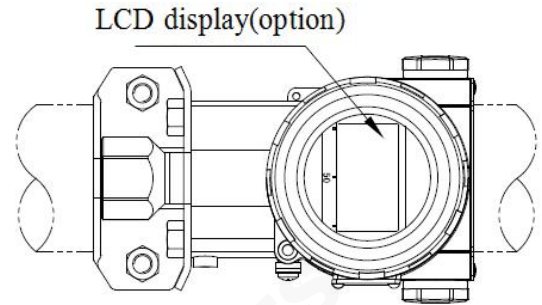
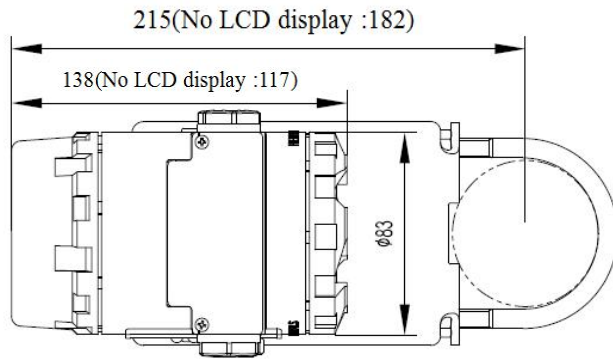

3 Horizontal Impulse Wall mounting Type

4 Vertical Impulse Piping Type

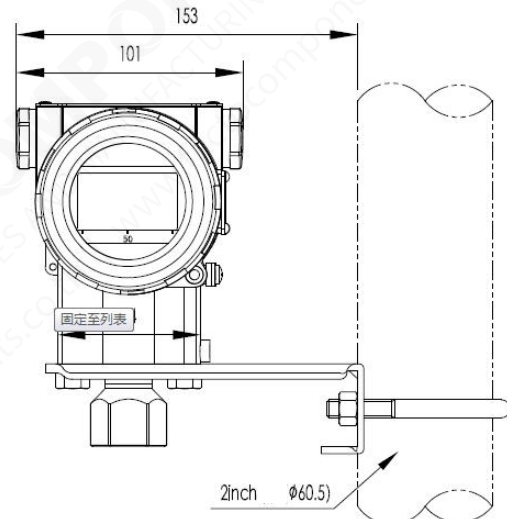
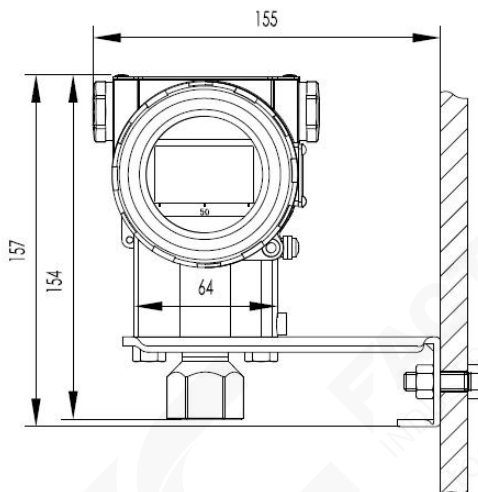

5 Terminal Configuration

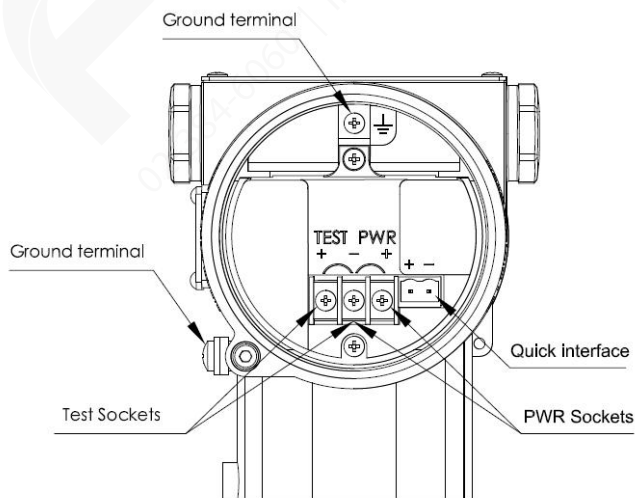

Note: Quick interface functionally equivalent to the signal terminal

6 Process connections Description

6.1 Standard type(model code 1)

(Span F/G/H/I/O)

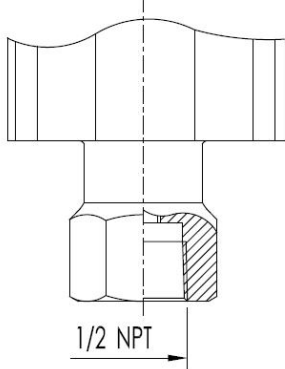

(Span B/C/R/S/L/T/M/D)

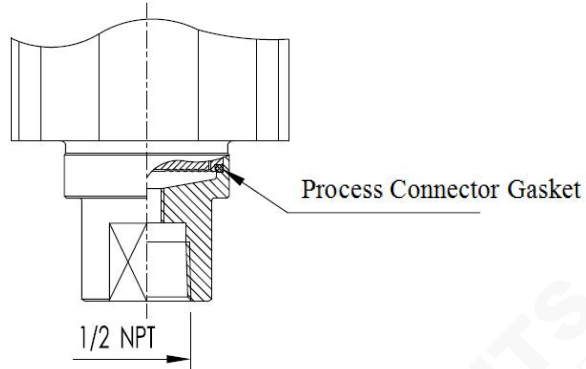

6.2 Other thread type

1/2 NPT male thread(model code 2)

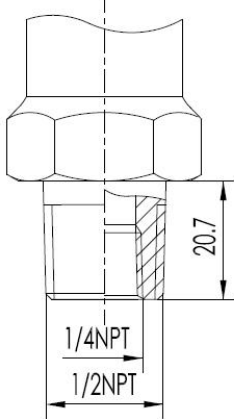

M20*1.5 male thread(model code 3)

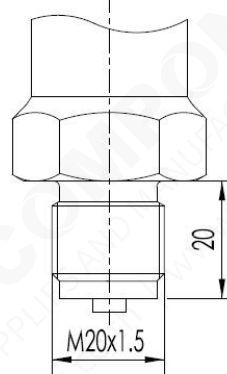

G1/2 male thread(model code 4)

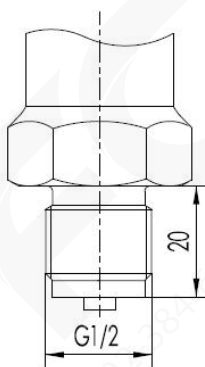

Vacuum interface DIN 28403 KF16(model code 5)

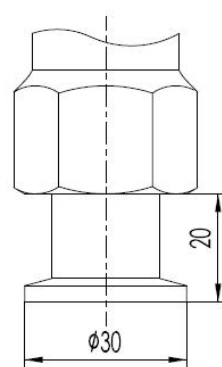

1/4 NPT male thread(model code 2)

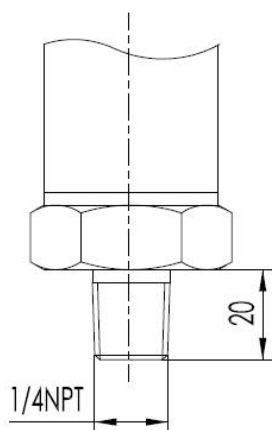

Pressure transmitter



7 Model and suffix codes

10 Accuracy									
	A	Reference Accuracy $\pm 0.05\%$ (not suitable for Span B & R)							
	B	Reference Accuracy $\pm 0.075\%$							
	C	Reference Accuracy $\pm 0.1\%$							
20 Span									
		RPI002 Gauge Pressure Transmitter							
	B	0 - 0.6kPa ~ 6kPa (0 - 60 ~ 600 mmH ₂ O) / (0 - 6 ~ 60mbar)							
	C	0 - 2kPa ~ 40kPa (0 - 200 ~ 4000 mmH ₂ O) / (0 - 20 ~ 400mbar)							
	D	0 - 2.5kPa ~ 250kPa (0 - 0.25 ~ 25 mH ₂ O) / (0 - 25 ~ 2500mbar)							
	F	0 - 30kPa ~ 3MPa (0 - 3 ~ 300 mH ₂ O) / (0 - 0.3 ~ 30bar)							
	G	0 - 0.1MPa ~ 10MPa / (0 - 1 ~ 100bar)							
	H	0 - 0.21MPa ~ 21MPa / (0 - 21 ~ 210bar)							
	I	0 - 0.4MPa ~ 40MPa / (0 - 4 ~ 400bar)							
	R	0 - 0.6kPa ~ 6kPa (0 - 60 ~ 600 mmH ₂ O) / (0 - 6 ~ 60mbar) [Overload protection 7MPa]							
	S	0 - 2kPa ~ 40kPa (0 - 200 ~ 4000 mmH ₂ O) / (0 - 20 ~ 400mbar) [Overload protection 7MPa]							
		RPI003 Absolute Pressure Transmitter							
	L	0 - 2kPa ~ 40kPa (0 - 200 ~ 4000 mmH ₂ O) / (0 - 20 ~ 400mbar)							
	M	0 - 2.5kPa ~ 250kPa / (0 - 25 ~ 2500mbar)							
	O	0 - 30kPa ~ 3MPa / (0 - 0.3 ~ 30bar)							
	T	0 - 2kPa ~ 40kPa (0 - 200 ~ 4000 mmH ₂ O) / (0 - 20 ~ 400mbar) [Overload protection 7MPa]							
30 Diaphragm & Fill Fluid									
		A	316L Stainless Steel	Silicone Oil					
		B	316L Stainless Steel	Fluorinated Oil					
		C	Hastelloy C	Silicone Oil					
		D	Hastelloy C	Fluorinated Oil					
40 Process Connector Accessory									
					1	1/2 - NPT Female Thread			
					2	1/2 - NPT Male Thread (Containing 1/4-NPT Female Thread)			
					3	M20x1.5 Female Thread			
					4	G1/2 Female Thread			
					5	Vacuum Connection DIN 28403 KF16 / ISO 2861			
					6	1/4 - NPT Male Thread			
					9	Heat Sink, 1/2 - NPT Female Thread			
50 Special Function									
					N	None			
					O	Degrease cleansing treatment (For Oxygen measurement with fluorinated oil filled capsule, Viton(FKM) gasket, <6MPa, <60 C)			
					P	Anti - lightning function			
60 Mounting Bracket									
					N	None			
					1	304 Stainless Steel			
					2	Carbon Steel Galvanized			
70 Integral Indicator									
					N	None			
					1	LCD Display (-20 C)			
					2	LCD Backlit Display (-20 C)			
					3	OLED Display (-40 C)			
80 Explosion Protected Type									
					N	None			
					A	Intrinsically safe Approval for NEPSI			
					D	Flameproof Approval for NEPSI			
					B	Intrinsically safe Approval for ATEX			
					E	Flameproof Approval for ATEX			
90 Tag Name Plate									
					N	None			
					1	Position number marked on the nameplate			
					2	Hanging stainless steel plate			
100 Manual									
					C	Chinese			
					E	English			
110 Additional Options									
					N	Perbunan (NBR) Gasket (only suitable for Span S)			
					D	Exd Cable Entry			
					E	Exe Cable Entry			
					F	Viton (FKM) Gasket (only suitable for Span S)			
					P	Teflon (PTFE) Gasket (only suitable for Span S)			
					S	Stainless steel Housing			