

## Disperses and prevents costly particle buildup

Activates up to 6 ft diameter of material • Cleaning distance up to 15 ft

### Reduce plant shutdowns • Improve material flow

**AcoustiClean® Sonic Horns** are designed to produce high-energy, low-frequency sound vibrations to disperse and prevent costly buildup of material in hoppers, bins, silos, boilers, ESPs, SCR, fans and more.

Sound waves are produced by applying compressed air to the sound generator, vibrating a high-strength titanium diaphragm. A typical pulse length is 10 seconds with each pulse using approximately 10 cfm of compressed air.

Our smallest horn, **Model ACL 17220** is ideal for activating material inside hoppers, bins and boilers. The effective cleaning distance is up to 15 feet in front of the horn and 6 feet in diameter.

- Easy to install – mount outside vessel or hang inside
- Improve process efficiency and productivity – fewer unscheduled shut downs for cleaning.
- Low maintenance – titanium diaphragm is the only moving part.
- Low operating cost
- Cast iron or stainless steel construction



### AcoustiClean® Sonic Horn Applications

**Boilers** – Cleans heat transfer surfaces to increase heat transfer efficiency and eliminate the need for soot blowers.

**Baghouses** – Helps reduce pressure drop across surfaces, extending bag life.

**Fans** – Eliminates material build-up on blades.

**Electrostatic Precipitators (ESP)** – Eliminates rapping system and wear to plates and wires.

**Silos, Bins, Hoppers** – Eliminates ratholing, bridging and prevents particulate buildup on vertical walls.

**Selective Catalytic Reduction (SCR)** – Cleans catalysts.

ACL 17220	
Frequency	220 Hz
Sound Pressure (Approximate range)	149 - 165 dB
Cleaning Distance	15 feet (4.57 m)
Cleaning Diameter	6 feet (1.83 m)
Weight	43 lb (20 kg)
Height	16.56" (0.42 m)
Air Requirements	
Air Pressure	70-90 psi (4.83 - 6.21 bar)
Air Volume	40-80 cfm

Specifications subject to change without notice.



**FACTO COMPONENTS CO., LTD. | บริษัท แฟคโตคอมโพเนนท์ จำกัด**

**CONTACT US: 845/3-4 หมู่ 3 อ.เทพารักษ์ ต.เทพารักษ์ อ.เมือง จ.สมุทรปราการ 10270**

**Tel. 02-384-6060 Email: info@factocomponents.co.th Website: www.factocomponents.co.th**



LINE OA: @factocomps

# Model ACL 17220 Dimensional Drawing

Specifications subject to change without notice.

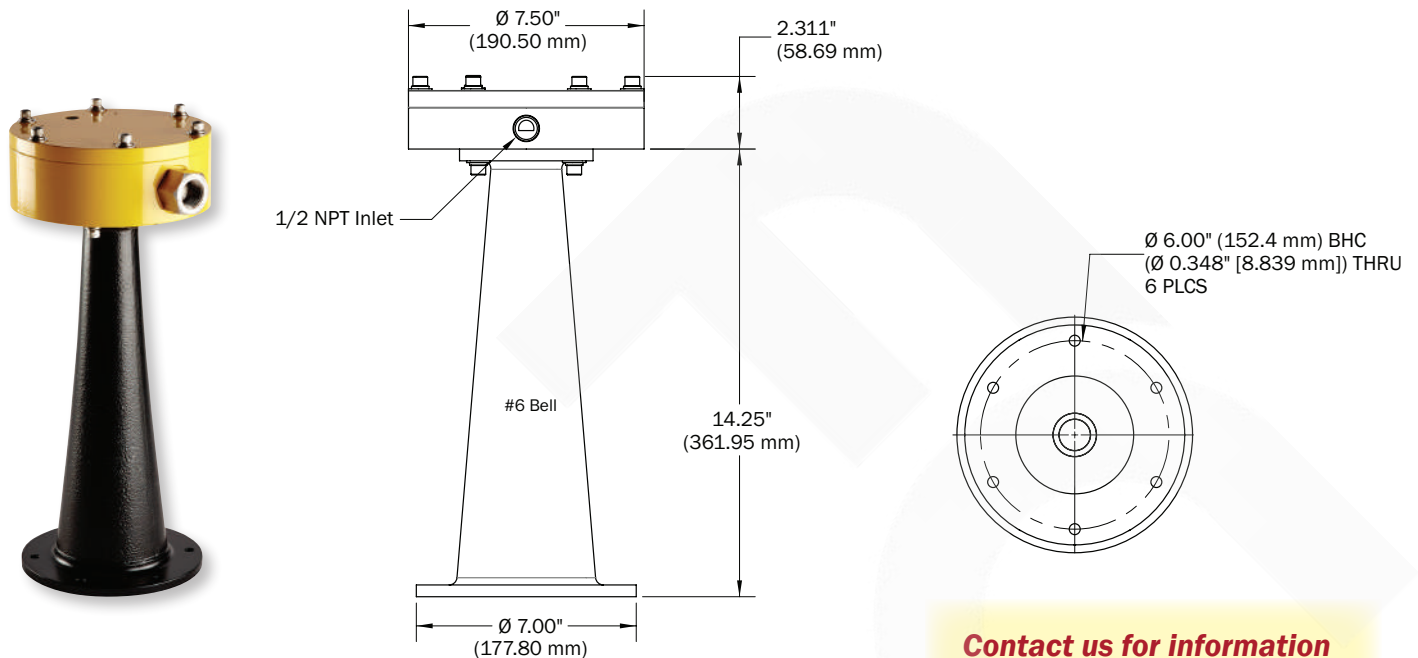

**Contact us for information and a detailed AcustiClean® proposal, engineered specifically for your application.**

## Recommendations for successful AcustiClean® sonic horn installation:

Vessel must be clean and free of deposits for facilitating optimal material flow.

The material must be relatively dry and powdery. Sonic horns are typically not effective if the moisture content is above 25%.

Compressed air pressure and volume must be maintained at 70-90 psi / 40-80 cfm to ensure horns are able to emit sound efficiently.

On boilers, the most effective installation will have the horn(s) blowing in the same direction as the pipes, where the acoustics can get between the pipes and the walls of the boiler. (For example, end-to-end.) Sounding the horn behind pipes on one side of the boiler toward pipes on the other side will generally not produce effective results.

# Typical AcoustiClean® Sonic Horn System Components

Specifications subject to change without notice.

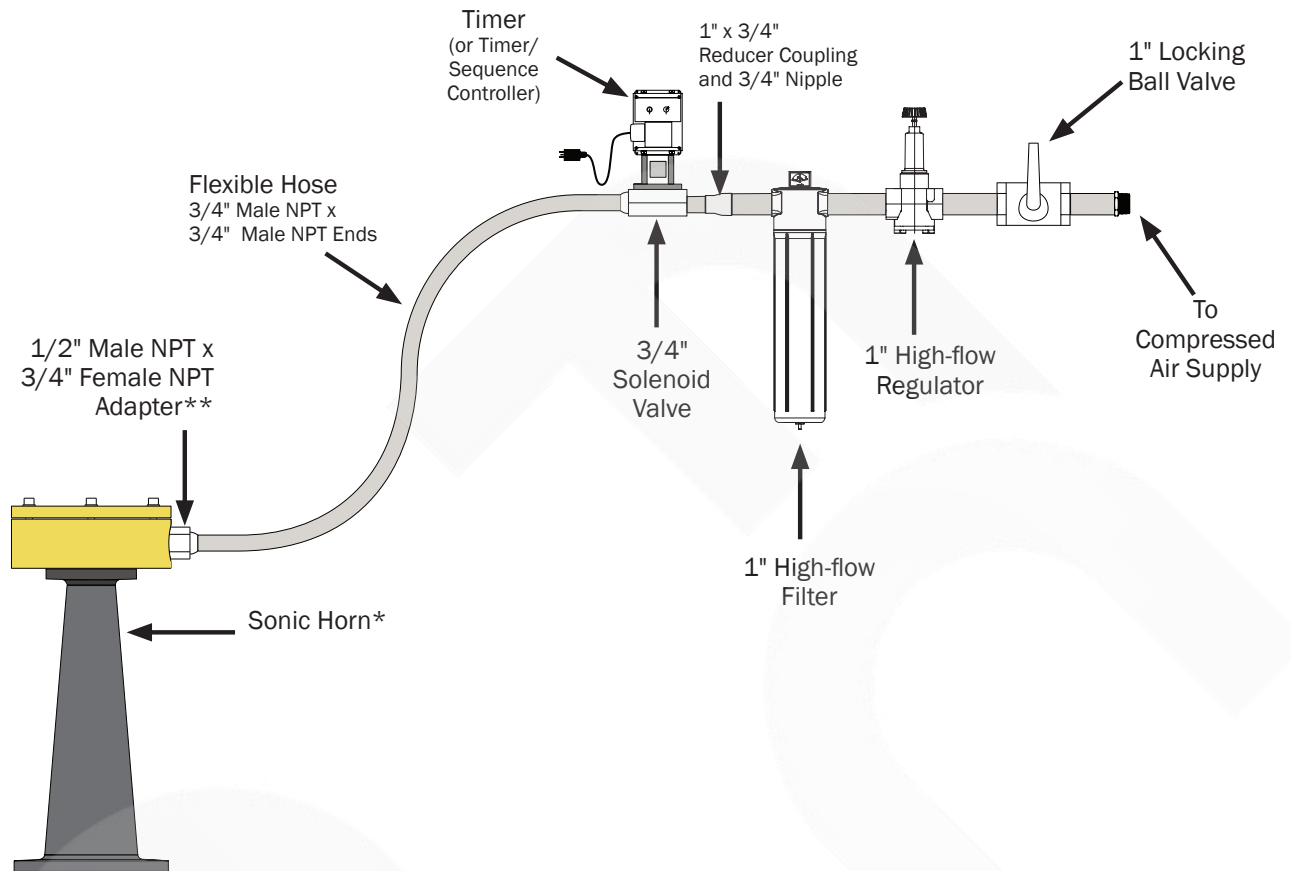

\* Sonic horn depicted is representative of a general horn and not a specific model.

\*\* 1/2" Male NPT x 3/4" Female NPT Adapter included with sonic horn.

## Typical Sonic Horn System Components

### Sonic Horn – Specify model number

#### Titanium Diaphragm

The only moving part in an AcoustiClean® sonic horn is the titanium diaphragm, which should be replaced annually.

#### Stainless Steel Flex Hose

Connects the solenoid valve and hard piping from your compressor.

#### Timers

Two options are available to control the interval and length of time the AcoustiClean® horn will sound.

- Timer/sequence controller designed to control multiple sonic horns.
- Timer plugs into the DIN contacts on the valve to control one horn.

#### Solenoid Valve

Controls the flow of air to the horn.

#### 1" High-flow Particulate Filter

Enhances life of system components by removal of in-line contaminants.

#### 1" high-flow Regulator

Necessary for regulating compressed air supply to within 70-90 psi for proper horn operation.

#### 1" Locking Ball Valve

Ideal for isolating the horn when system maintenance is required.